

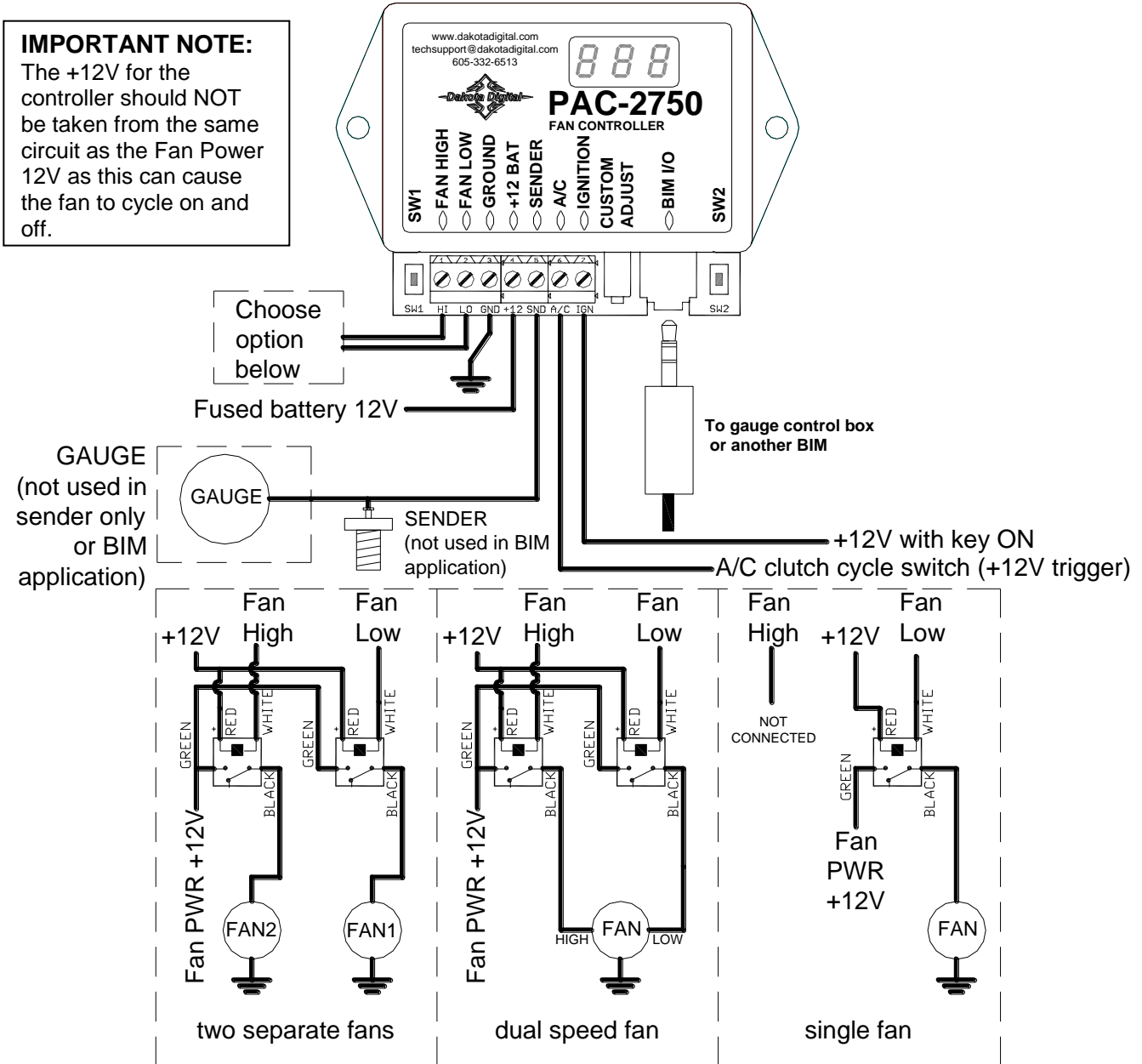

PAC-2750 ELECTRIC COOLING FAN CONTROLLER

IMPORTANT NOTE:
The +12V for the controller should NOT be taken from the same circuit as the Fan Power 12V as this can cause the fan to cycle on and off.



Required components for installation:

The PAC-2750 is shipped with necessary components for use with a single fan on a gauged system. These parts include:

- 1 PAC-2750 module
- 1 RLY-3 relay with wiring harness
- 1 BIM data cable
- 1 BIM-xx-2 adapter harness
- 1 Instruction manual

For some options of the PAC-2750, additional components are required. These are listed below.

- Second RLY-3 assembly (needed for dual fan or two speed fan operation)
- 300°F sender Dakota Digital temp sender (for operation without a gauge)
- PAC-PWM-1 module for variable speed control of a fan (this takes the place of the fan low relay)

Operation

The electric cooling fan controller provides a way to run up to two electric engine cooling fans or one two speed cooling fan. (A second relay, sold separately, is required for two speed or dual fan operation). The controller monitors the engine temperature using a dedicated sender, a gauge and its sender, or directly from a Dakota Digital BIM connection. When the engine temperature goes above a user adjustable set point, the fan is turned on with a relay. When the engine has cooled below a user selectable off temperature, the fan is shut off. Separate on and off temperatures can be set for the high and low fan outputs. The controller will also run the fan when the air conditioner requires, by detecting when the air conditioning clutch is engaged. Variable speed fan control is possible with the purchase of a PAC-PWM-1 unit. The fan speed will vary between the Fan Low Off setting up to full speed at the Fan Low On setting. When the temperature information is provided by a Dakota Digital BIM connection, a high speed shut-off is also available to disable the fans from turning on once the vehicle is above a user adjustable speed.

The unit can be set to keep the fan running (if the engine is hot enough) after the key is turned off. Several delay times are available from no delay to five minutes. The display will countdown the seconds left before the fan is turned off. If the battery voltage drops too low, the fan will be turned off and a "Lo BAt" message will display for the remainder of the time.

Settings for several gauge systems are included to make installation with a gauge easier. The included gauges are Stewart Warner, Classic Instruments, VDO, and Autometer. If the gauge being used isn't included, a custom calibration option allows the system to be calibrated to any gauge with clear numerical temp markings. This is accomplished by setting the controller to match the marks on the gauge with a few steps described in detail in the installation instructions. The engine temperature can also be read directly from an OBDII diagnostic port with the use of a Dakota Digital BIM-01-X unit.

WARNING!!!: *The fan will turn on and run continuously if the sender is disconnected as a failsafe. Always keep clear of the fan unless the battery is disconnected. When entering setup mode with a VHX or VFD gauge system and the PAC-2750 connected with a BIM cable the fan will begin running continuously after a 2 minute delay.*

IMPORTANT NOTE!!!: *If using a gauge with this unit, always ensure that your gauge is working properly. If the gauge is not reading correctly, the fan control unit will not have correct temperature information and cannot be guaranteed to properly control the fan, possibly leading to overheating and engine damage.*

If the gauge uses a two-wire temperature sender (such as Autometer full sweep) use of a dedicated Dakota Digital sender is required.

If a gauge is not used, ONLY a Dakota Digital 300°F sender should be used (Dakota Digital part SEN-04-1, SEN-04-2, SEN-04-4, SEN-04-5, SEN-04-6, SEN-04-7, or SEN-04-8). Other senders may not give a correct reading to the control unit.

Custom gauge calibration requires numerical marks, stock "C-NORMAL-H" type gauges cannot be accurately calibrated to.

Installation

Note: Mount ONLY in vehicle cabin. Controller is not designed for engine compartment mounting.

The terminal strip on this unit has 7 connections:

1. Fan high relay Connect to the white wire on the high fan relay assembly
(for single fan applications leave unconnected)
2. Fan low relay Connect to the white wire on the low fan relay assembly or PAC-PWM-1 module
3. Ground Connect to a good chassis ground
4. Power Connect to a fused 12V battery
5. Sender Connect to the engine temperature sender wire.
6. A/C clutch Connect to the cycle switch on systems with air conditioning (+12v)
(on systems without air conditioning leave unconnected)
7. Ignition Connect to a circuit which has +12V only with the ignition key ON. (switched power)

Relay wiring:

- | | |
|-------|---|
| White | Connect to control unit |
| Green | Connect to fused 12V battery circuit that can run cooling fan |
| Red | Connect to fused 12V battery |
| Black | Connect to cooling fan |

Factory Presets

This controller comes preset to use a dedicated sender as follows:

- Dakota Digital Sender only (no gauge, see note above for 300°F sender options)
- One single speed fan
- 205°F on temperature
- 200°F off temperature
- 30 sec Fan off delay

If the factory settings don't fit your application, you will need to go through the setup procedure on the following page. At anytime during the setup procedure, the key may be turned off and the settings up to that point will be saved.

Set Up

1. Press and hold SW2, then turn the key on.
2. Release SW2, then press and release SW1 to move onto the next step.
3. To select temperature scale to use, press and hold SW1 to select *F* (Fahrenheit) or press and hold SW2 for *C* (Celsius). Hold the switch for longer than one second to select. Once a temperature scale is selected, the display will flash and go on to next setting.
4. Display will now read *LON* indicating low fan on temperature is to be set. Use SW1 or SW2 to select the temperature at which the fan should turn on. Press both switches to save the setting. Display will flash when setting is saved. When using a PAC-PWM-1 for variable speed control, this will be the 100% speed setting.
Note: SW1 increases the temperature, while SW2 decreases the temperature.
5. Display will now read *OFF* indicating low fan off temperature is to be set. Again, use SW1 or SW2 to set the temperature at which the fan should turn off. Press both switches to save the setting. When using a PAC-PWM-1 for variable speed control this will be the 0% speed setting.
6. If two fan or dual speed fan mode was previously selected, temperature settings for the high fan output are at this point in setup for convenience. If single fan mode is set up, setup will skip high temp settings and go to Step 7.
 - 6a. Display will now read *HON* indicating high fan on temperature is to be set. Use SW1 or SW2 to set the temperature at which the fan should turn on. Press both switches to save the setting.
 - 6b. Display will now read *OFF* indicating high fan off temperature is to be set. Use SW1 or SW2 to set the temperature and press both switches to save the setting.
7. Display will read *dLY* Use SW1 or SW2 to cycle through the following options. Press both switches to select an option.

<u>Display</u>	<u>Option</u>
<i>OFF</i>	Fan will turn off when key is turned off.
<i>0.5</i>	If fan was running at key off, it will continue to run for 30 seconds after key is turned off.
<i>0.7</i>	If fan was running at key off, it will continue to run for 45 seconds after key is turned off.
<i>1.0</i>	If fan was running at key off, it will continue to run for 1 minute after key is turned off.
<i>2.0</i>	If fan was running at key off, it will continue to run for 2 minutes after key is turned off.
<i>3.0</i>	If fan was running at key off, it will continue to run for 3 minutes after key is turned off.
<i>5.0</i>	If fan was running at key off, it will continue to run for 5 minutes after key is turned off.

8. Display will read *FAN* indicating fan type is to be set. Use SW1 or SW2 to select the fan type used. Press both switches to save setting.

<u>Display</u>	<u>Option</u>
<i>1</i>	one single speed fan (only low fan output used)
<i>2</i>	two single speed fans (high <u>and</u> low fan outputs both on for high temp, & some dual spd fans only low fan output on for low temp)
<i>SPd</i>	one dual speed fan (high fan output on, low fan off for high temp, high fan off, low fan on for low temp)

Note: If two fan or dual speed are selected and high fan temp setting was not set before, setup will return to Step 6 to allow temp settings to be made.

9. Display will read *URr* to select whether a PAC-PWM-1 will be connected to the FAN LOW output for variable speed control. Use SW1 or SW2 to change this setting between *ON* or *OFF*. Press both switches to save setting.

- 9a. If *ON* is selected the display will read *5Er* to show the minimum starting duty cycle to begin operating the fan at. Use SW1 or SW2 to change the starting duty cycle. Press both switches to save the setting.

<u>Display</u>	<u>Option</u>
<i>20</i>	20%
<i>30</i>	30%
<i>40</i>	40%
<i>50</i>	50%

- 9b. Next the display will show *FRE* to select the fan frequency for the PAC-PWM-1 to use. The settings range from *1* (slowest) to *8* (fastest). Use SW1 or SW2 to change the frequency. Press both switches to save the setting.

10. Display will read *5nd* signaling to select a sender type. Press SW1 to move through list forward, press SW2 to back up. Press both switches to save setting. The supported senders are listed below with the display that represents each option.

<u>Display</u>	<u>Option</u>
<i>no</i>	No gauge, dedicated Dakota Digital sender only
<i>dd1</i>	Dakota Digital individual temp gauge with sender
<i>dd2</i>	Dakota Digital instrument cluster with control box (ver. STR-D or later, older versions use CUS)
<i>StE</i>	Stewart Warner gauge and sender
<i>CLS</i>	Classic gauge and sender
<i>VdD</i>	VDO gauge and sender
<i>AtD</i>	Autometer gauge and sender
<i>bUS</i>	Dakota Digital BIM connection
<i>CUS</i>	Custom calibrated gauge
<i>CRl</i>	Custom calibration (for gauge sets not listed above)

- 10a. If *bUS* is selected, the display will read the current BIM mode. Press SW1 to move through list forward, press SW2 to back up. Press both switches to save setting. The supported senders are listed below with the display that represents each option.

<u>Display</u>	<u>Option</u>
<i>AutD</i>	Automatically select the bus operation mode.
<i>SL1</i>	Connect to a VHX, VFD3 (SE47 or higher), or VFD3X (SE56 or higher) system.
<i>SL2</i>	Connect to a VFD3 (SE46 or earlier) or VFD3X (SE55 or earlier) system.
<i>PAC</i>	PAC-2750 is a master connected to a BIM-01-X or similar unit.

- 10b. If *bUS* is selected, following the BIM mode selection, the display will show *d15* and then allow a high speed disable to be set or turned off. The speed will be shown in MPH when the temperature is Fahrenheit or km/h when using Celsius. Use SW1 or SW2 to set the speed at which the fan should turn off. Press both switches to save the setting.

11. If your gauge is not supported in one of the options above, you will need to custom calibrate the controller for your gauge. (if *CUS* is selected and calibration has not been done, the calibration sequence will automatically be started). The following is the procedure for custom calibration. If your gauge system is listed above, skip this portion and continue at Step 12.

Custom Calibration

Note 1: If your engine is warm you may need to disconnect the wire from your sender in order get to the lower points on the gauge.

Note 2: If the key is turned off in custom setup, the previous gauge setting will be used and the custom gauge will not be saved.

Note 3: If your gauge does not have defined ticks with numerical temp readings, it is highly recommended to use a dedicated sender as calibration to the gauge is very inaccurate or impossible without temp markings.

CC1. Select *CRl* in Step 9 on the previous page. Display will read *Adj*.

CC2. Turn the potentiometer on the lower right corner of the unit (marked CUSTOM ADJUSTMENT) with a small flat screw driver. While doing so, watch your temp gauge and line up the needle with the **lowest temperature tick** on the gauge. **Custom gauge must be calibrated starting at cold temperatures and moving to hot temperatures.**

Note: Turning potentiometer clockwise increases temperature reading.

CC3. Once the gauge is set to a tick, press SW1 or SW2. A temperature reading will appear on the display. Scroll to the temp reading that matches the tick temperature reading on the gauge using SW1 to increase and SW2 to decrease. Press both buttons to save the number. Display will again read *Adj*.

CC4. Repeat steps CC2 and CC3 with the next lowest tick on gauge until all the ticks on your gauge have been set. (up to 6 but no less than 4 points). Press both SW1 and SW2 at *Adj* to stop setting points if there are less than 6 points on your gauge. If there are more than 6 points on your gauge, select points over the full range of the gauge (cold to hot). This will give a better match to your gauge.

12. Unit will flash *BBB* to indicate set up is complete. The unit now has been set up. If the wiring and setup have been properly completed the unit should begin normal operation at this point.

Resetting Factory presets

This procedure will return the device to the original factory presets and clear custom calibration settings.

NOTE: Calibration data for the custom gauge setup will be lost when reset to factory presets.

1. Turn key off.
2. Press and hold SW1 and SW2 and turn key on.
3. Display will read *rE5* for reset
4. Display will flash *BBB* to indicate unit is reset. Factory reset values are listed at the beginning of the setup portion of this manual.

Checking set up (diagnostic mode #1)

This unit comes with a feature to allow you to mimic normal operating temperatures using the adjustment pot. This can allow you to test the installation before ever starting the engine. Just follow these steps.

1. Turn the key on.
2. Press SW1 and SW2 at the same time and hold. A number representing the temperature will come up on the display. This number will blink once to indicate that the unit has entered diagnostic mode. SW1 and SW2 may now be released and the unit will remain in diagnostic mode until the key is turned off.
3. Adjust the potentiometer on the left side of the unit while watching the display and listening for the fan. The fan should start when the display reads hotter than the set ON temp. It should again shut off when the display reads lower than the OFF temp.
4. You may also look at your water temperature gauge (if unit is using a gauge) and compare the temperature reading of the unit to the gauge. The temperatures should be within a few degrees. If not, the wrong gauge may be selected in the setup routine. Go through setup again by turning off the ignition, pressing and holding SW2 and turning ignition back on. If a selection cannot be found that closely matches your gauge you may have to custom calibrate to your gauge. (see Step 10 in setup)

Testing Fan operation (diagnostic mode #2)

A second diagnostic mode allows you to test the fan operation for the mode you have set. This can be used to verify dual speed, dual fan, or variable speed fan operation without running the engine. Just follow these steps.

1. Turn the key on.
2. Press SW1 and SW2 at the same time and hold. A number representing the temperature will come up on the display. This number will blink once to indicate that the unit has entered diagnostic mode. Release SW1 and SW2.
3. Now press SW1 and SW2 together again. This time the display will flash and then display "o-r" "oFF" and the fans will be off.
4. Pressing SW2 will increase the fan setting, pressing SW1 will decrease the fan setting. To exit this diagnostic mode, turn off the ignition.

	Variable speed off	Variable speed on
1 FAN	oFF – on	oFF – 0.5 – on
2 FAN	oFF – Lo – HI	oFF – 0.5 – Lo – HI

Checking the current reading

The current temperature reading can be displayed on the unit at anytime during normal operation without going into the diagnostic mode. Simply press and hold SW1 while the key is on and the PAC-2750 is not in setup or diagnostic mode. The current temperature will be shown on the display until the SW1 is released. If the temperature is not shown and the dot on the display flashes rapidly then the ignition input on the PAC-2750 is not getting power when the key is on.

TROUBLESHOOTING

PROBLEM	CAUSE	SOLUTION
Display reads "E-0" (lost memory)	Setup memory lost, unit needs to be recalibrated	Go through setup procedure, (see setup in this manual).
Display reads "E-1" (shorted sender)	Wrong gauge selected	Select proper gauge in setup or use custom cal if needed.
	Gauge disconnected from sender (gauge option only)	Reconnect gauge to sender.
	Sender is shorted	Check sender wire for short to ground, look for pinched sender wire or bare connection touching ground.
	Unit not connected to sender	Connect SENDER terminal on unit to sender circuit.
Display reads "E-2" (open sender)	Wrong gauge selected	Use setup to select proper gauge, or use custom cal if needed.
	Sender not connected	Reconnect wire to sender.
	Unit not connected to sender	Connect SENDER terminal on unit to sender circuit .
Display reads "E-3"	Setup data is out of valid range	Go through setup again, custom cal may be incorrect.
Display reads "bAL" when attempting to go into setup	+12v terminal does not have constant power	Connect +12 BAT terminal to fused battery connection. This terminal should have constant power at all times.
Display alternates between "Lo" and "bAL"	Battery voltage dropped too low during key off extended fan on time	Ensure battery is fully charged. Check and replace weak battery. Shorten fan delay time to prevent excessive battery drain.
Fan turns on early, late, or not at all	Unit has no constant power. (Display will not show anything when SW1 is held)	Connect +12 BAT terminal to constant power and GROUND terminal to a good ground.
	Unit has no keyed power. (dot on display flashes rapidly when SW1 is held)	Connect IGNITION terminal to a circuit powered when the key is on.
	Broken/shorted wire to sender	Check wire to sender for breaks or shorts and repair.
	Wrong gauge is selected (gauge setup)	Hold SW1, if temperature read is lower than expected or doesn't match gauge, redo setup.
	Wrong sender used (for no gauge setup)	For sender only applications ONLY a Dakota Digital 300°F sender can be used. Other senders may not give a correct temperature reading.
	Wrong bus type set (for BIM gauge setup)	For early VFD3/3X systems select <i>bUS - 5L2</i> to read the temperature correctly.
	On temperature in setup is too high	Hold SW1, if temperature read is above the desired on temperature, and fan is not running, redo setup.
	Fan not connected properly	Remove fan output from unit and short wire to ground. If fan does not run, check relay and fan connections.
	Display shows "SPd". Speed shut-off is set too low.	Turn off or raise the high speed disable setting.
	Alternator overcharging (Analog gauge applications only)	Use a voltmeter to measure the voltage at the battery while the engine is running. If this voltage is above 15v the unit may turn the fan on later than expected. Either correct overcharging problem or set on temp lower to compensate.

TROUBLESHOOTING (continued)

PROBLEM	CAUSE	SOLUTION
Fan runs constantly	Controller has an error	Check display for error message.
	Fan off temp too low	Increase off temp in setup.
	Broken/shorted wire to sender	Check wire to sender for breaks or shorts and repair.
	Wrong gauge is selected	Select appropriate gauge in setup, or custom calibrate if your gauge is not supported.
Custom gauge setup displays "Err" and returns to "5nd" setup option	Not enough points used	Make sure that at least 4 points of gauge are set
	Points not input in correct order	Set gauge points in order from cold points to hot points
	Point entered twice	Each point set must be different than the point before it
Fans cycle on-off especially when engine temp is close to On/off set point	+12v for controller taken from same circuit as the fan power +12V (green wire on relays)	Connect the +12V for the controller to a different circuit separate from the circuit connected to fan relays.

PAC-2750 specifications		
SETTINGS		
Minimum Fan On Temp	150° F (65 C)	
Maximum Fan On Temp	250° F (121 C)	
SUPPLY		
Voltage Input (+12) Range	6.3 to 22 V	
Key Off Current (+12)	< 0.001 A	
Key On Current (+12)	< 0.025 A	
INPUTS		
	Off voltage	On voltage
Ignition	< 2.2 V	> 5.6 V
A/C Clutch	< 2.2 V	> 5.6 V
OUTPUTS (to turn on relay)		
Fan Low, High (maximum)	1.5 A	

Included relay specifications	
Typical Coil Current	0.175 A
Relay Contacts Max Current	70 A (14VDC)

SERVICE AND REPAIR

DAKOTA DIGITAL offers complete service and repair of its product line. In addition, technical consultation is available to help you work through any questions or problems you may be having installing one of our products. Please read through the Troubleshooting Guide. There, you will find the solution to most problems. **Should you ever need to send the unit back for repairs, please call our technical support line, (605) 332-6513, to request a Return Merchandise Authorization number.** Package the product in a good quality box along with plenty of packing material. Ship the product by UPS or insured Parcel Post. Be sure to include the RMA number on the package, and include a complete description of the problem with RMA number, your full name and address (street address preferred), and a telephone number where you can be reached during the day. Any returns for warranty work must include a copy of the dated sales receipt from your place of purchase. Send no money. We will bill you after repair.

Dakota Digital 24 Month Warranty

DAKOTA DIGITAL warrants to the ORIGINAL PURCHASER of this product that should it, under normal use and condition, be proven defective in material or workmanship within 24 MONTHS FROM THE DATE OF PURCHASE, such defect(s) will be repaired or replaced at Dakota Digital's option.

This warranty does not cover nor extend to damage to the vehicle's systems, and does not cover removal or reinstallation of the product. This Warranty does not apply to any product or part thereof which in the opinion of the Company has been damaged through alteration, improper installation, mishandling, misuse, neglect, or accident.

This Warranty is in lieu of all other expressed warranties or liabilities. Any implied warranties, including any implied warranty of merchantability, shall be limited to the duration of this written warranty. Any action for breach of any warranty hereunder, including any implied warranty of merchantability, must be brought within a period of 24 months from date of original purchase. No person or representative is authorized to assume, for Dakota Digital, any liability other than expressed herein in connection with the sale of this product.



4510 W. 61st St. North
 Sioux Falls, SD 57107
 www.dakotadigital.com
 dakotasupport@dakotadigital.com

Phone (605) 332-6513
 Fax (605) 339-4106

Copyright 2011 - Dakota Digital, Inc.