



# CRC-2000

## Drive-by-Wire Cruise Control System

**This manual covers the aspects of installation, operation, and troubleshooting of the CRC-2000 “Drive-by-Wire” cruise control.**

The CRC-2000 was designed to work with CAN bus GM LS engine/drivetrain packages, as either a complete transplant from a stock vehicle, or a Connect Cruise, using a GM ECU programmed with US SAE code.

- Works with 2008 and newer GM CAN bus engine/drivetrain packages with US SAE code.
- Requires a 4,000 Pulse Per Mile VSS square wave speed signal.
  - GM ECU Speed output or VSS Out, (not VSS High).
  - Dakota Digital SPD OUT from a control box.
- Mix and match engines, transmissions and ECUs will most likely NOT work.
- Advanced tuning to the ECU could disable the cruise control operation.
- The CRC-2000 is designed to only work with a GM CAN bus computer system.
  - Not designed for Ford, Mopar, or aftermarket EFI systems like Holley



**Table of Contents**

<b>Parts List</b>	<b>Page 2</b>
<b>Connectors and Pin Outs</b>	<b>Page 3</b>
<b>Wiring / J2 Main Harness</b>	<b>Page 4</b>
<b>Wiring / J2 Optional Resistor Wiring</b>	<b>Page 6</b>
<b>Wiring / J2 Clutch Switches</b>	<b>Page 6</b>
<b>Wiring / J2 Brake and LED Relay</b>	<b>Page 7</b>
<b>Wiring / J3 Cruise Handles</b>	<b>Page 9</b>
<b>Wiring / J4 Throttle connections</b>	<b>Page 10</b>
<b>Trouble Shooting</b>	<b>Page 12</b>
<b>Operations</b>	<b>Page 13</b>
<b>Safety Procedures</b>	<b>Page 14</b>
<b>Service / Warranty</b>	<b>Page 16</b>

## PARTS LIST

The kit includes the standard parts

Item	Quantity	Description	Part Number
1	1	Cruise Control Module	CRC-2000
2	1	Pedal Interface Harness	250-2766
3	1	Main Power / Input Harness	250-2759

Three cruise handles are offered: two column mount models and a dash mount version. The column models use a different interface harness than the dash mount model. The appropriate harness will be supplied with the handle chosen at purchase time.

Part	Style	Mounting	Harness
HND-1	Cut-off style	Requires cutting off original plastic of turn signal	394207
HND-2	Dash Mount	Requires three holes drilled into dash or console	394206
HND-3	<1980 GM turn signal replacement	Replaces older GM turn signal with screw	394207

(The harness 394206 could also be used with four wire GM stock turn signal levers built for cruise, page [9])

The colors will vary some on the 394207, so matching a wire color to color will not always be feasible. See the wiring diagrams for proper connections to the cruise handles on page [8].

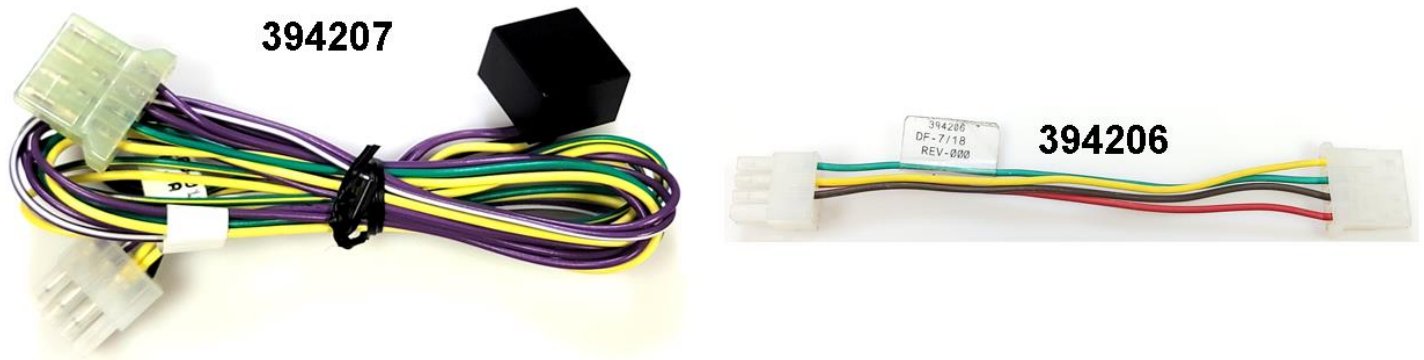

Pedals vary in build and operation. The pin layout must be a single row as shown in the purple pedal plug of the **250-2766** below. If the pins are turned, or the pedal has a dual row of pins, the CRC-2000 will not function, and the wiring cannot be modified "to make work".

For proper pedal operation, a voltage test can be found on page [12].



# CONNECTORS AND PIN OUTS

The CRC-2000 has four connectors on the front that we use.

They are labeled as:

- J1 – **Not Used**
- J2 – Power/Ground/Input harness
- J3 – Handle/Switch harness
- J4 – Pedal harness



The small connector in the back is not used, but there is a small cutaway for an LED, that can be used to observe operation and limited diagnostics, (see page [12]).

## Overall plug colors with the different handle harnesses

Colors of the 394207 may not match exactly as shown below.

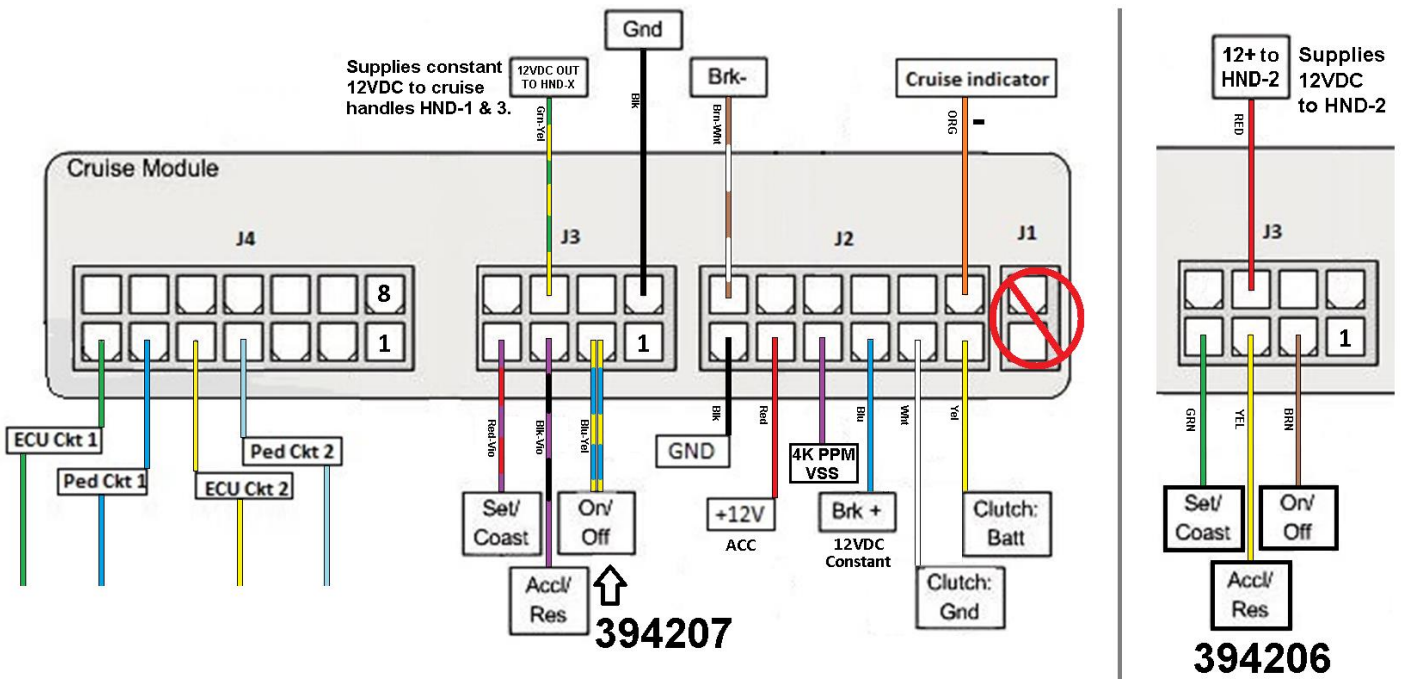

# STEP BY STEP CONNECTIONS

## Connecting Main Harness [J2]

### Wire colors

<b>Orange</b>	Ground Output to activate “cruise” indicator on Dakota Digital dash or ground side of LED
<b>Yellow</b>	Clutch Switch triggered by a positive voltage
<b>White</b>	Clutch Switch triggered by a ground signal
<b>Purple</b>	Speed input wire – requiring a 4,000 pulse per mile, square wave signal
<b>Blue</b>	Constant power (hot side of brake pedal can work)
<b>Red</b>	Key on power, accessory or ignition from fuse panel
<b>Black</b>	Chassis ground
<b>White/Brown</b>	Cold side of brake switch

➤ When connecting leads to a vehicle, soldering is preferred over crimp connectors.

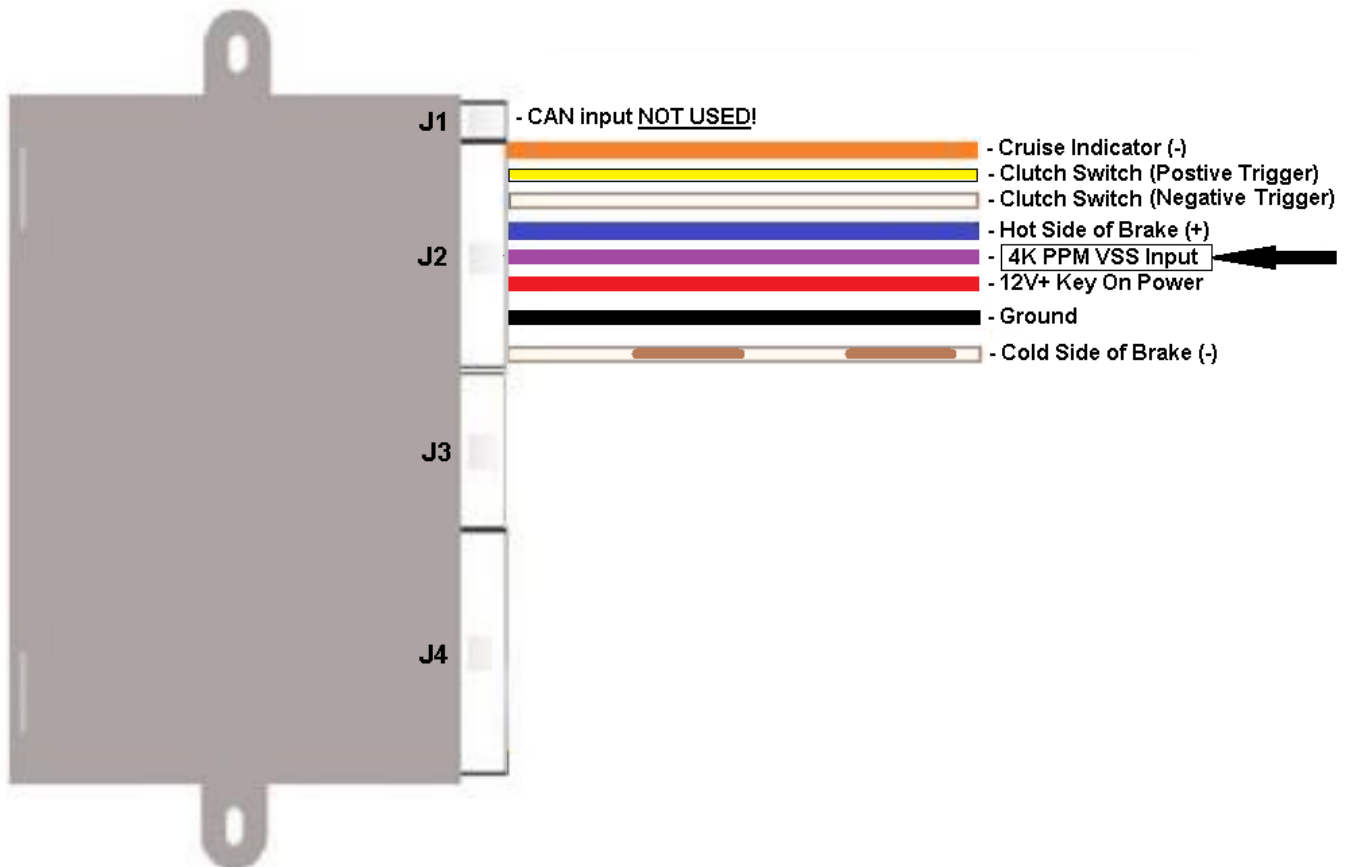

### Pinout of J2 Connector

WHITE / BROWN Brake - (cold side)					ORANGE Cruise Indicator (-)
BLACK Ground	RED Power	VIOLET 4K PPM VSS FROM ECM	BLUE Brake + (hot side)	WHITE Optional Clutch SW	YELLOW Optional Clutch SW

## VSS Pull Up Resistor [J2]

The Purple VSS wire in J2 requires the device sending out a speed signal have, what is called a pull up voltage. This can be determined to exist by testing the output wire or terminal for DC voltage.

Many ECUs have a 5-volt reference voltage with key the on.

Dakota Digital control boxes do not have a pull up voltage, and the enclosed resistor will need to be added.

### Basic Diagram

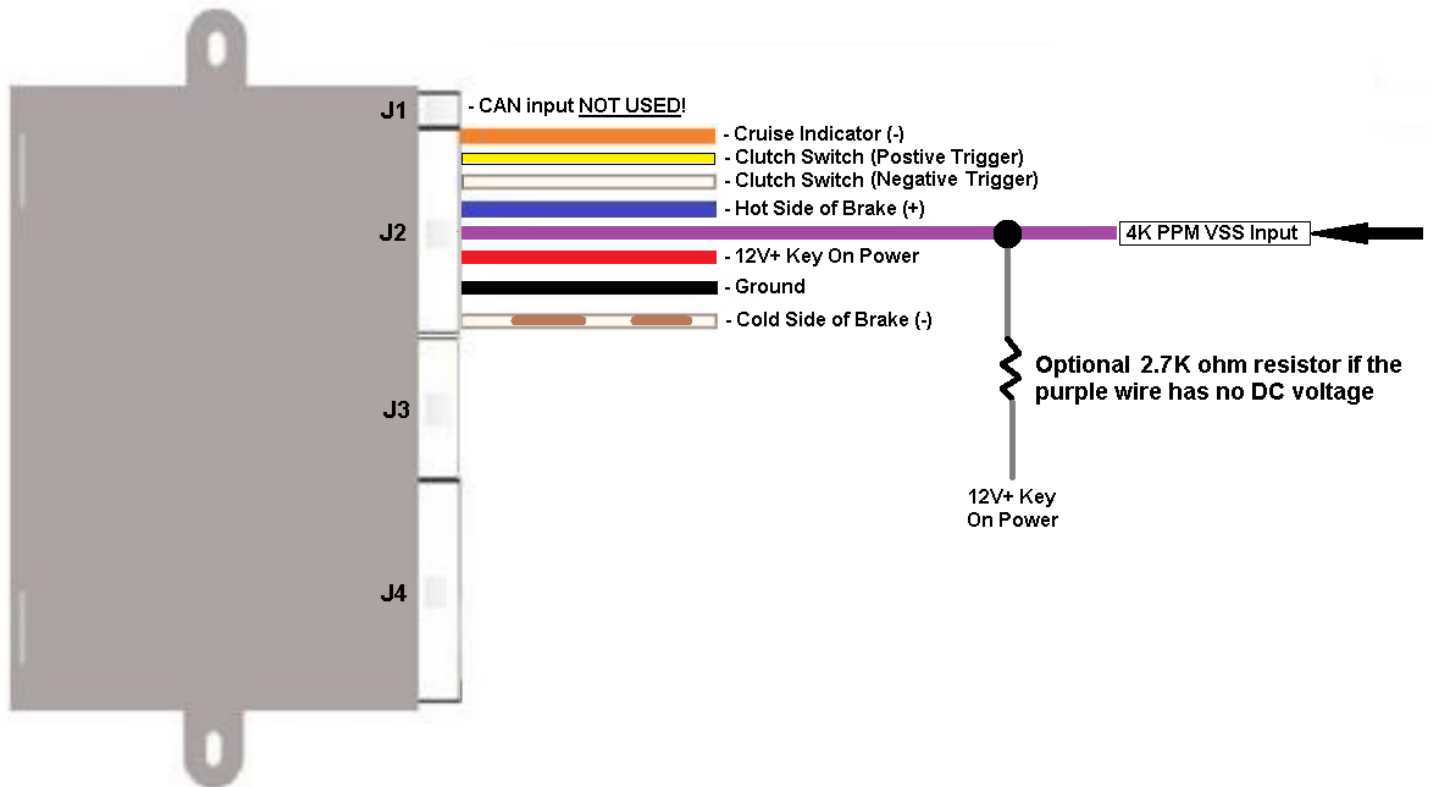

All Dakota Digital control boxes, (and the GPS-50-2 CRUISE terminal), will need the pull up resistor added, as long as the control box is being fed a speed signal into the speed input wires.

> The SPD OUT of the control box must be configured to "4K" in the setup for the dash.

> The SPD OUT will **NOT** generate a signal if the control box is getting speed from a BIM-01-2, or GPS-50-2 connected with the BIM cable.

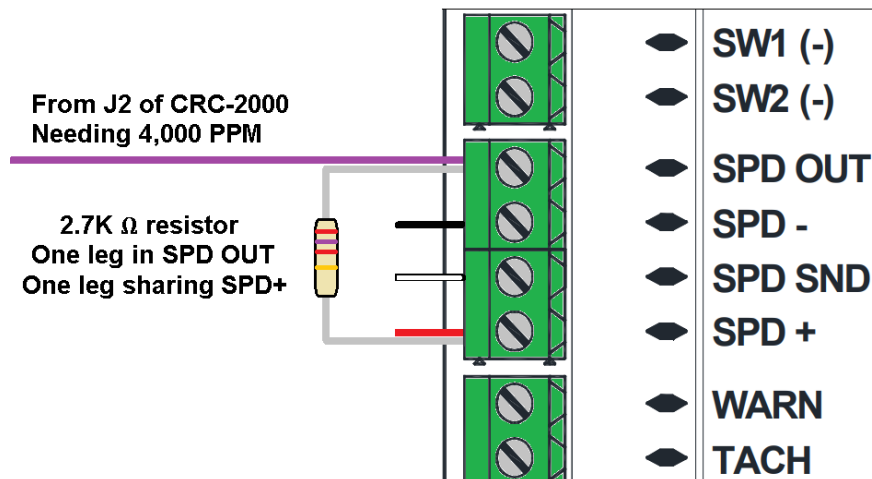

## Special Wiring Notes

### Cruise Indicator (Orange):

The orange wire produces a negative trigger to operate the cruise indicator on a Dakota Digital VFD3, VHX, HDX or RTX dash system. The orange wire will connect to "CRUSE" on these control boxes. The orange wire could also operate the ground side of a LED lamp.

### Clutch Switch wires (Yellow and White):

- Optional – Only for manual transmissions.
- If using an automatic transmission **DO NOT CONNET EITHER WIRE TO ANYTHING.**
- If using a clutch switch that is a ground trigger, **DO NOT CONNET** the yellow wire to anything.
- If using a clutch switch that is a positive trigger, **DO NOT CONNET** the white wire to anything.

## Clutch Switch Wiring Examples

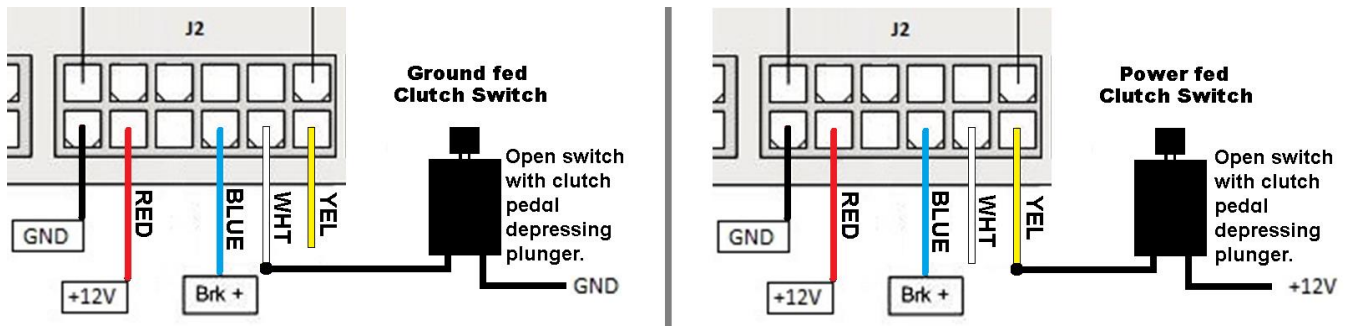

Example of clutch switch mounting.

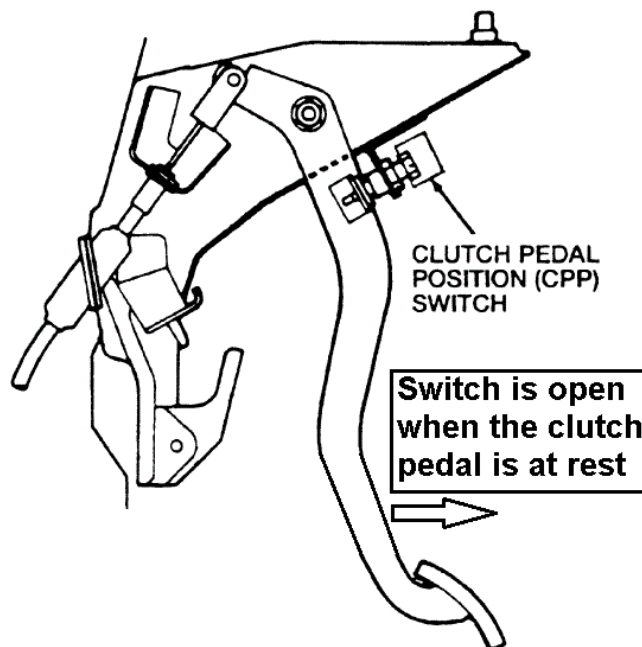

# Original Brake Switch

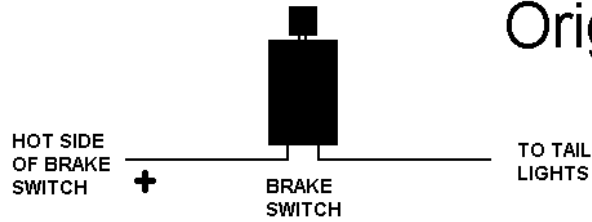

Open switch with brake pedal depressing plunger

# Brake Switch with Cruise added

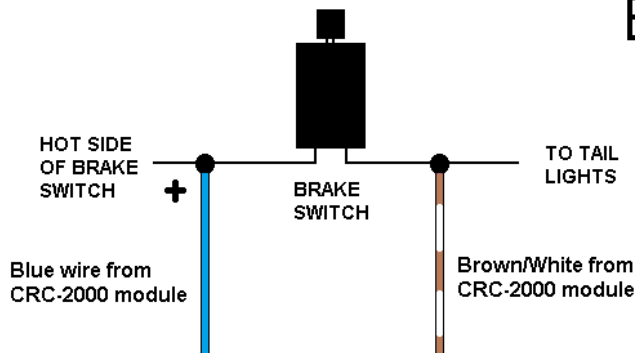

# Brake Switch w/ Cruise and Relay for LED taillights

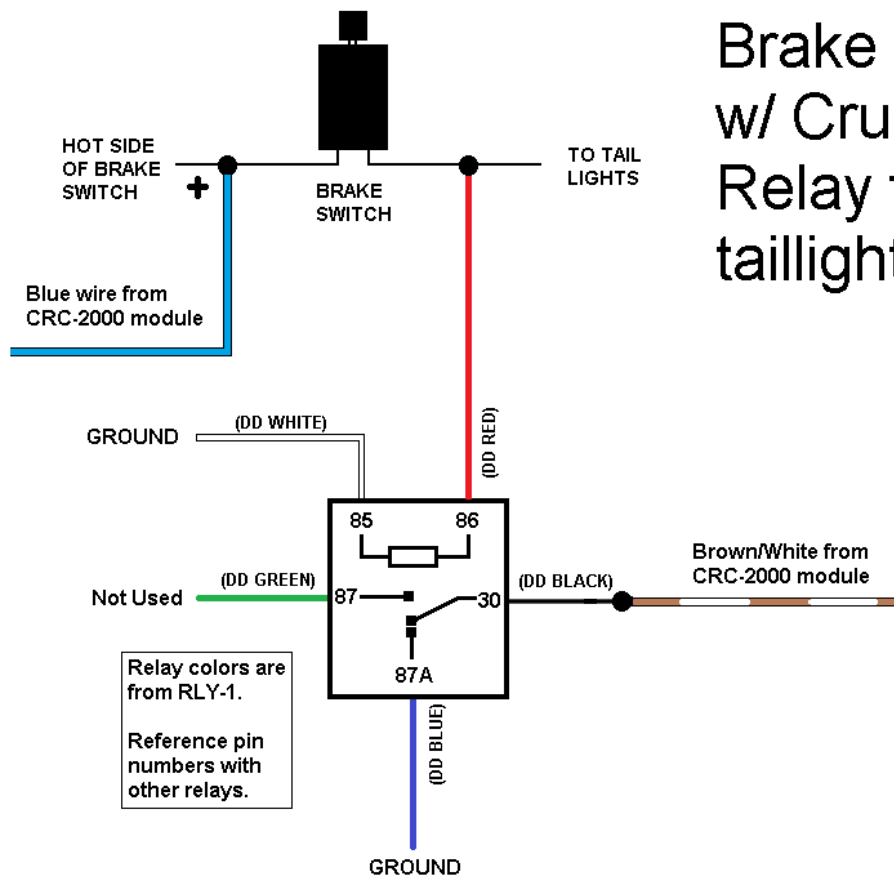

## Handle Wire Harnesses [J3]

### 394207 with HND-1 or HND-3

This is a pretty much a plug and play connection.

**When pinning the plug of the handle, match the colors of the handle to the letters on the plastic plug.**

The Dakota Digital HND-1 and HND-3 can only be used with the 394207 harness.

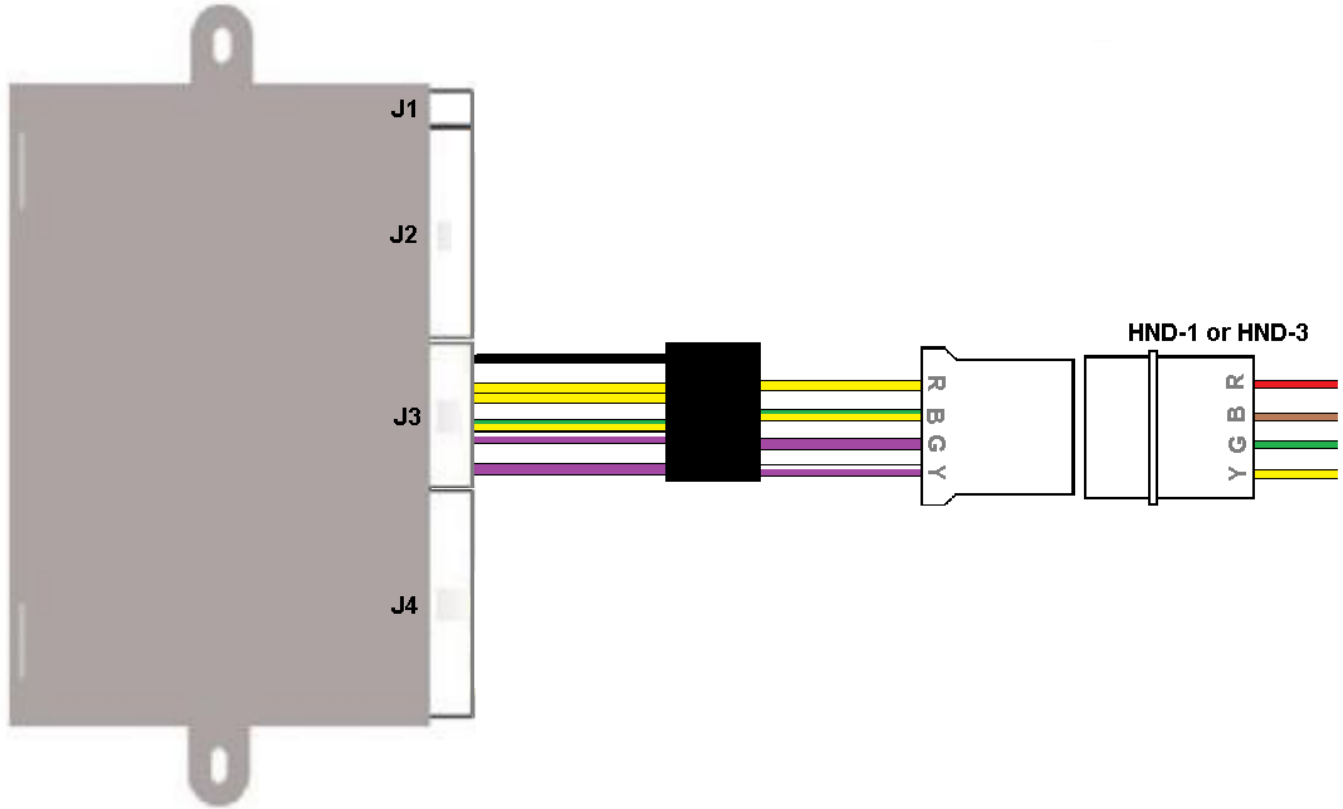

The colors of the 394207 may vary, and these are the known variants we have seen.

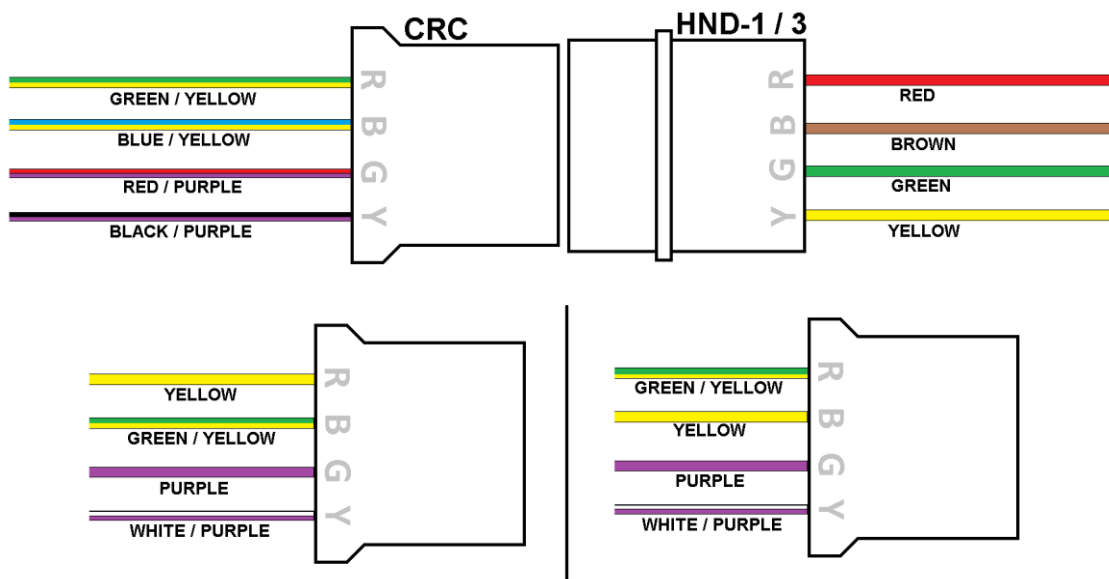



## Handle Wire Harnesses [J3]

### 394206 with HND-2

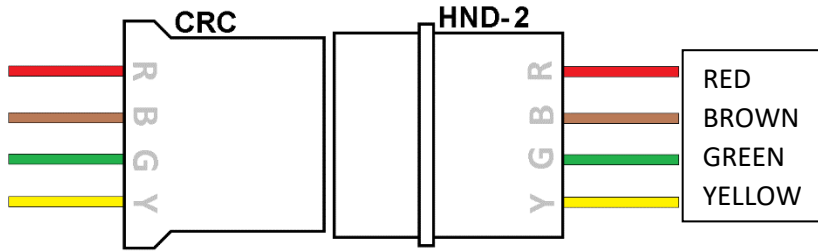

The HND-2 colors will match the colors of the 394206 harness.

The HND-2 **cannot** be used with the 394207 harness.

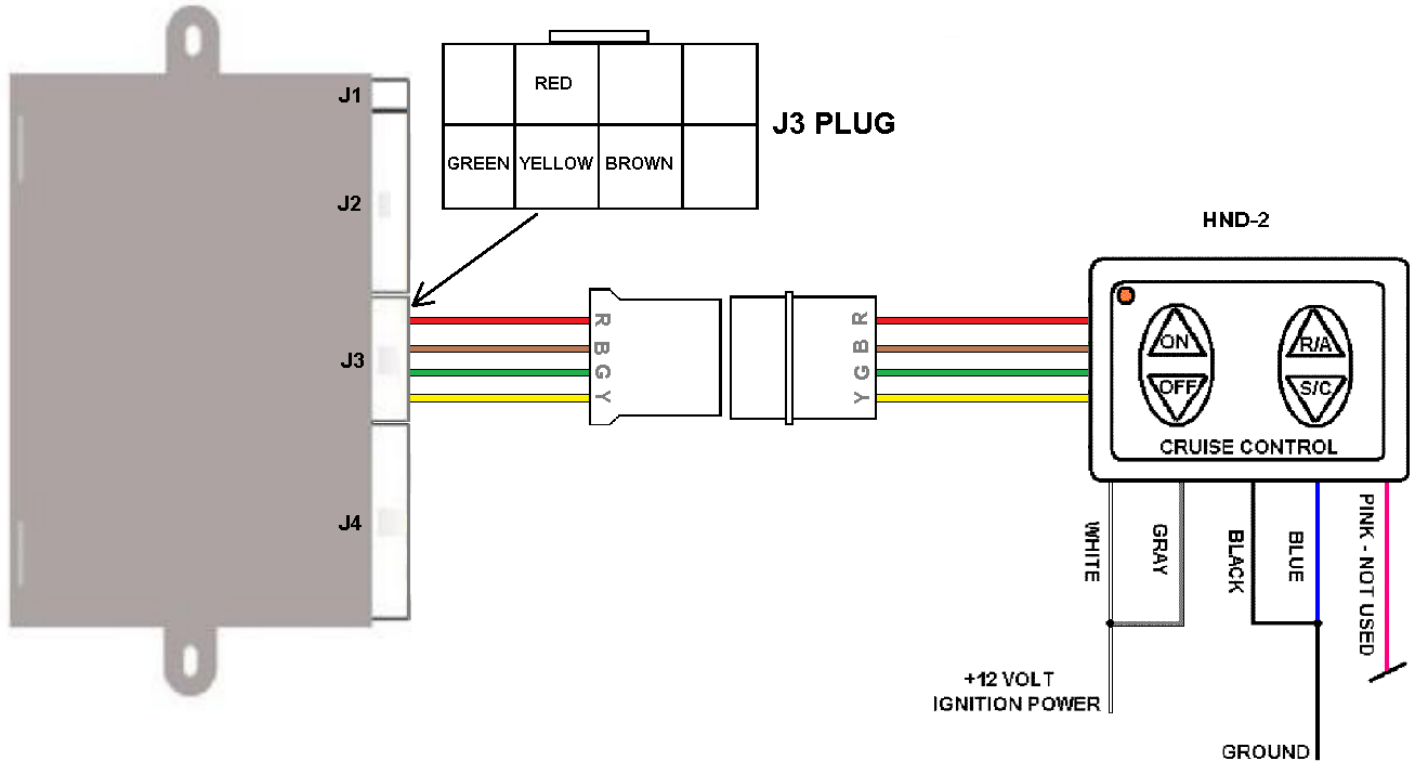

On occasion, a GM stock turn signal lever with cruise can be used with the 394206.

GM used different colors at times.

Refer to the pinout on page [3] of the operational function of each wire of the 394206 harness.

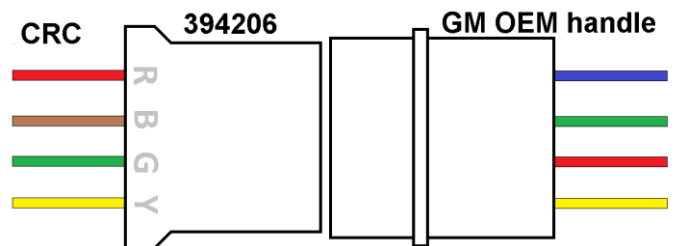

### Possible GM wiring colors to the 394206 harnesses:

Function	394206 Colors	GM Colors	GM Colors	GM Colors	GM Colors
Resume/Accel	Yellow	Yellow	Gray/Black	Green	Dark Gray
Set/Coast	Green	Red	Blue	Blue	Dark Blue
On	Brown	Green	Gray	Gray	Gray
Power in	Red	Blue	Pink	Pink	Pink/Black

## Throttle Pedal Harness [J4]

The throttle pedal harness is also a plug and play style, only for a GM pedal, and only for one style. The pins must be side by side; not front to back, nor a dual row of pins. The harness **cannot** be rewired for different pedals as they may operate on different voltages.

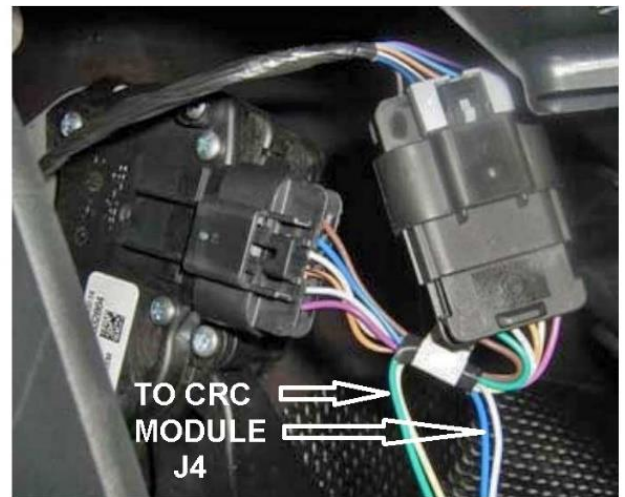
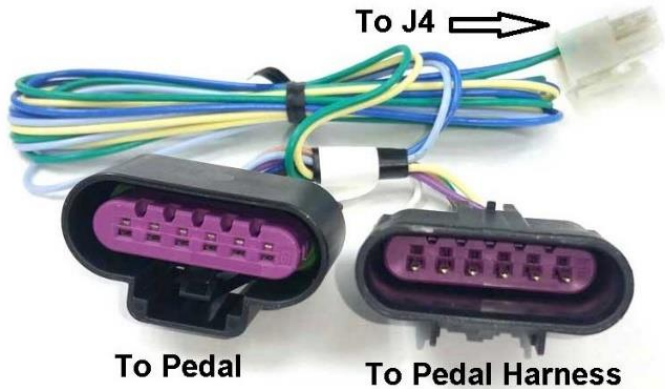
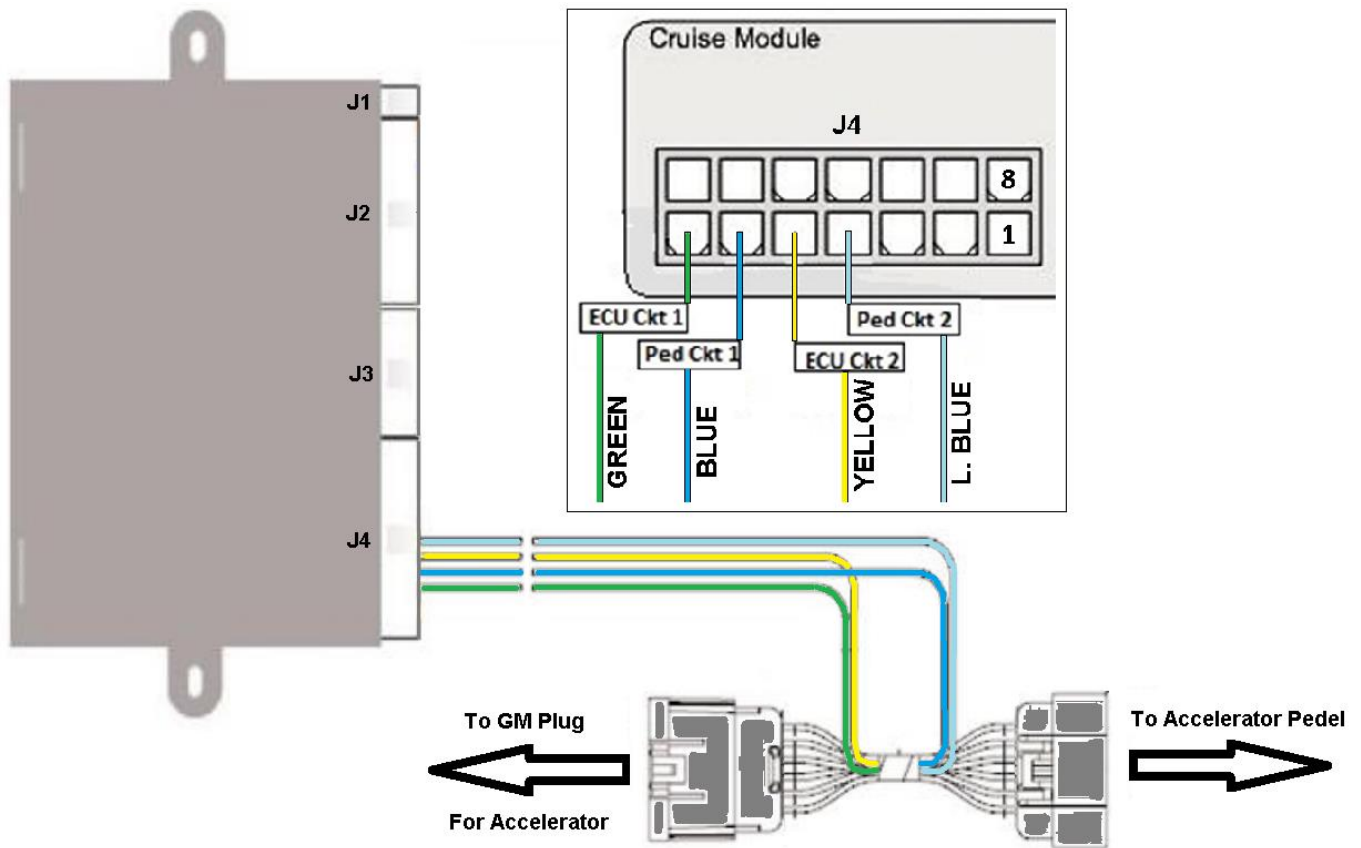

## GM Throttle Wire Colors

GM colors and certain pins can be different, let alone aftermarket harness colors.

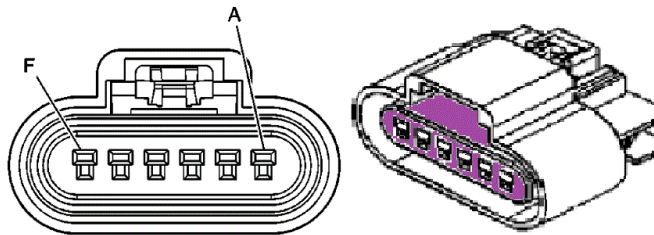

The GM throttle pins are labeled A through F.

**B and E must retain the same voltage ranges in order for the pedal and cruise to function.**

A, C, D, and F can be ground or power, as our throttle harness merely acts as a pass through.

When looking for a ground reference to ground the CRC-2000 to, one needs to verify the correct wire.

2008-2013 Silverados and Sierras – Color Pattern of 250-2766 throttle harness

Color	Pin Location	Function	Voltage
Purple	A	Low Reference	Ground 0 Volts
Light Blue	B	Sensor 2 Signal	0.5 V at rest <> 2 V wide open
Light Brown	C	5 Volt Reference	5 Volts
White / Black	D	5 Volt Reference	5 Volts
Blue	E	Sensor 1 Signal	1 V at rest <> 4 V wide open
Brown	F	Low Reference	Ground 0 Volts

From various Vettes and Camaros from 2008 to 2013

Color	Pin Location	Function	Voltage
Purple	A	Low Reference	Ground 0 Volts
Light Blue	B	Sensor 2 Signal	0.5 V at rest <> 2 V wide open
Tan	C	5 Volt Reference	5 Volts
Brown	D	Low Reference	Ground 0 Volts
Blue	E	Sensor 1 Signal	1 V at rest <> 4 V wide open
White / Black	F	5 Volt Reference	5 Volts

2009 Trailblazer

Color	Pin Location	Function	Voltage
Tan	A	5 Volt Reference	5 Volts
Light Blue	B	Sensor 2 Signal	0.5 V at rest <> 2 V wide open
Purple	C	Low Reference	Ground 0 Volts
Brown	D	Low Reference	Ground 0 Volts
Blue	E	Sensor 1 Signal	1 V at rest <> 4 V wide open
White / Black	F	5 Volt Reference	5 Volts

Painless Harness colors in a LS3 Connect and Cruise swap

Color	Pin Location	Function	Voltage
Purple	A	Low Reference	Ground 0 Volts
Light Blue	B	Sensor 2 Signal	0.5 V at rest <> 2 V wide open
Red	C	5 Volt Reference	5 Volts
Brown	D	Low Reference	Ground 0 Volts
Blue	E	Sensor 1 Signal	1 V at rest <> 4 V wide open
White / Black	F	5 Volt Reference	5 Volts

# TROUBLE SHOOTING

## Pedal Voltage Tests

The pedal voltages have to be within a certain tolerance for the cruise to operate. Testing J4 pins will require a volt meter for accurate voltages, a test light will not work. Key on only, with pedal harness fully connected, measure the following pins on J4 (see page 10).

Color at J4	Pedal at Rest	Pedal Wide Open	Tolerance
Green	1 Volt	4 Volts	+/- 0.3 volts
Blue	1 Volt	4 Volts	+/- 0.3 volts
Yellow	0.5 Volt	2 Volts	+/- 0.3 volts
Light Blue	0.5 Volt	2 Volts	+/- 0.3 volts

## Handle Voltage Tests [J3]

	+12 VOLTS		
SET / COAST	ACCEL/ RESUME	CRUISE ON	

**+12 VOLTS** – supplies power to handle with key on.  
**CRUISE ON** – will have power when the cruise handle is turned on.  
**SET/COAST** – will have power when the Set/Coast button is pressed.  
**ACCEL/RESUME** – will have power when the Accel/Resume button is pressed.

## LED status light

<b>Green</b>	On - Ready to operate	Off or short blink - loss of power or ground
<b>Amber</b>	On - Operating normally	Short flash – Switch functions, but cannot engage
<b>Red</b>	On - CRC is seeing a fault	

Problem	Possible cause	Solution
Throttle goes into "limp mode"	<ul style="list-style-type: none"> <li>- Intermittent power</li> <li>- Poor ground</li> <li>- Began after ECU was tuned</li> <li>- Incorrect pedal voltage operation</li> </ul>	<ul style="list-style-type: none"> <li>- Properly connect red lead of J2 to proper power</li> <li>- Use different ground – connect black wire of J2 to throttle pedal ground, pin A (purple)</li> <li>- Restore to previous tune and troubleshoot tuning adjustments</li> <li>- Refer to pin voltages on page 10 and voltage test above for correct pedal</li> </ul>
Cruise not engaging	<ul style="list-style-type: none"> <li>- No power on J2 Red or Blue</li> <li>- No ground on J2 Black</li> <li>- No ground on J2 White/Brown</li> <li>- Incorrect handle harness used</li> <li>- Incorrect pedal voltage operation</li> </ul>	<ul style="list-style-type: none"> <li>- Verify power and grounds at J2</li> <li>- Connect black wire of J2 to throttle pedal ground, from the ECU side. (Purple is commonly used as ground)</li> <li>- Verify grounding of White/Brown to conventional brake lights</li> <li>- Use a relay if using LED tail lights or if the brake bulb sockets are rusty</li> <li>- Our turn signal handles use harness 394207, HND-2 and GM stock four wire handles use 394206 (pages 8 and 9)</li> <li>- Refer to pin voltages on page 11 and voltage test above for correct pedal</li> </ul>
Cruise disengages when using turn signals	<ul style="list-style-type: none"> <li>- Turn signals feeding back into brake circuit</li> </ul>	<ul style="list-style-type: none"> <li>- Add relay on page 7 to isolate feedback voltage</li> </ul>
Cruise surges	<ul style="list-style-type: none"> <li>- Throttle too sensitive</li> </ul>	<ul style="list-style-type: none"> <li>- HP Tuner can make the throttle less sensitive</li> </ul>
Cruise runs away	<ul style="list-style-type: none"> <li>- Wrong VSS pulse rate</li> </ul>	<ul style="list-style-type: none"> <li>- Verify the supply pulse rate is configured for 4,000 PPM</li> </ul>

## **OPERATING INSTRUCTIONS**

NOTE \*\*If the cruise indicator (-) is wired, the indicator may light for up to 10 seconds upon power up. This is normal.

**ON:** To operate the Cruise Control, turn the power button ON. (Green LED Indicator will light, if equipped.) Wait three (3) seconds before setting speed.

**SET SPEED:** To engage system, press SET/COAST or press RESUME/ACCEL and release, then remove your foot from the accelerator pedal. Press accelerator and speed will increase, release accelerator and you will return to set speed.

**COAST:** Press and hold the SET/COAST button and your speed will decrease. Release button and speed of vehicle at time button is released will be new set speed.

**ACCEL:** Press and hold the RESUME/ACCEL button and your speed will increase. Release button and you will have a new higher set speed.

**TAP-UP:** You can gradually increase your speed by quickly pressing and releasing the RESUME/ACCEL button. Each time you press and release the button your speed will increase by 1 MPH.

**TAP-DOWN:** You can gradually decrease your speed by quickly pressing and releasing the SET/COAST button. Each time you press and release the button your speed will decrease by 1 MPH

**DISENGAGE:** Depress brake pedal slightly; automatic speed control will cease but set speed will stay in the system's memory. Also, you can disengage by pressing button to OFF position, but this erases the memory. To get the RESUME feature to work again, you must first set a speed. Turning OFF the ignition also clears the systems memory.

**RESUME:** After disengaging system with brake or clutch, press RESUME/ACCEL button and release it. If acceleration rate is faster or slower than you like, drive to within a few MPH of your set speed, then press and release the RESUME/ACCEL button.

### **About Dakota Digital Cruise Control**

The performance of the Cruise Control is dependent upon the condition of the engine, its size and even by the type of emission control equipment it has. Driving at higher altitudes will have an effect on Cruise Control's performance.

Under normal conditions and with proper switch settings, speed should be controlled within plus or minus 1 MPH. There may be situations; however, which make it seem as if the Cruise Control is not capable of functioning accurately, such as an extra heavy load, a very steep hill, or a severe headwind.

**CAUTION:** Do not use the Cruise Control on a slippery road or in heavy traffic.

**CAUTION:** (Manual Transmission) While driving with the Cruise Control ON, do not shift to neutral without depressing the clutch pedal, as this may cause engine to over-rev. If this happens, depress the clutch pedal or turn OFF the main Cruise Control Switch immediately.

OUR QUALIFIED EXPERT TECHNICAL SERVICE DEPARTMENT IS READY TO ASSIST YOU WITH ANY QUESTIONS OR PROBLEMS THAT YOU MAY HAVE ABOUT OUR PRODUCT. CONTACT US VIA PHONE AT (605) 332-6513 (USA) OR FAX AT (605) 339-4106 (USA).

## **SAFETY PROCEDURES**

This unit is a microprocessor-based Cruise Control. It is designed for ease of installation. Carefully follow the installation procedures in this manual for best results.

**DO NOT INSTALL THIS SYSTEM ON A DIESEL-POWERED VEHICLE WHICH HAS A MANUAL TRANSMISSION WITHOUT A DISENGAGEMENT SWITCH ON THE CLUTCH PEDAL ASSEMBLY.**

(Contact Dakota Digital Sales to purchase part: SEN-4206)

### **WARNING**

Failure to follow the instruction manual could not only cause the system to work improperly, but could cause the vehicle to go into 'limp-mode', possibly causing damage to your vehicle and injury and/or death to you and your passengers.

Only install on approved applications. The product described in this manual was developed, manufactured and tested in line with recognized technical standards and is in compliance with the fundamental safety requirements. Nevertheless, there are residual risks! It is therefore important to read this manual before installing and connecting the product. Keep the manual in a place that is readily accessible at all times.

### **Modifications to the product**

The cruise control is designed, manufactured and tested with due regard to safety and reliability. Modifying or tampering with the product can affect its safety. This can lead to death, serious or slight injury to the driver or third parties, or damage to property or the environment. For this reason, the product must not be modified or tampered with!



**WARNING: DO NOT USE HAND-HELD 2-WAY TRANSCEIVERS INSIDE YOUR VEHICLE WHILE DRIVING.**

WHEN TRANSMITTING FROM INSIDE THE CAR, 2-WAY RADIOS THAT OPERATE IN THE 25MHz-700MHz FREQUENCY RANGE WITH MORE THAN 2.0 WATTS OF POWER CAN PRODUCE ELECTROMAGNETIC INTERFERENCE THAT COULD INTERFERE WITH THE OPERATION OF CRUISE AND THROTTLE CONTROLS RESULTING IN VEHICLE "LIMP MODE".

USE OF CELLULAR PHONES WILL NOT INTERFERE WITH THESE CONTROLS.



**DUE TO SENSITIVE NATURE OF SIGNALS USED FOR THIS PRODUCT, ALL NON-PLUG AND PLAY CONNECTIONS MUST BE SOLDERED. FAILURE TO COMPLY WITH THIS REQUIREMENT WILL VOID WARRANTY.**

**⚠ WARNING:** This product can expose you to chemicals including lead, which is known to the State of California to cause cancer and birth defects or other reproductive harm. For more information go to [www.P65Warnings.ca.gov](http://www.P65Warnings.ca.gov)

**PAGE INTENTIONALLY LEFT BLANK**

## **SERVICE AND REPAIR**

DAKOTA DIGITAL offers complete service and repair of its product line. In addition, technical support is available to help you work through any questions or problems you may be having installing one of our products. Please read through the Troubleshooting Guide. There, you will find the solution to most problems.

For additional support, please visit [www.dakotadigital.com](http://www.dakotadigital.com). A “**Product Support**” link will be found at the bottom of the home page.

**Should you ever need to send the unit back for repairs, please call our technical support line, (605) 332-6513, to request a Return Merchandise Authorization number.**

- Package the product in a good quality box along with plenty of packing material.
- Ship the product by a common carrier with tracking abilities.
- Be sure to include the RMA number on the package.
- Include a complete description of the problem, with RMA number, your full name and address (street address preferred), and a telephone number where you can be reached during the day.
- Any returns for warranty work must include a copy of the dated sales receipt from your place of purchase.
- Send no money. We will contact you for payment.

## **Dakota Digital 36 Month Warranty**

DAKOTA DIGITAL warrants to the ORIGINAL PURCHASER of this product that should it, under normal use and condition, be proven defective in material or workmanship for 36 MONTHS FROM THE DATE OF PURCHASE, such defect(s) will be repaired or replaced at Dakota Digital's option.

This warranty does not cover nor extend to damage to the vehicle's systems, and does not cover diagnosis, removal or reinstallation of the product.

This Warranty does not apply to any product or part thereof which in the opinion of the Company has been damaged through alteration, improper installation, mishandling, misuse, neglect, or accident.

Dakota Digital assumes no responsibility for loss of time, vehicle use, owner inconvenience nor related expenses. Dakota Digital will cover the return standard freight once the product has been evaluated for warranty consideration, however the incoming transportation is to be covered by the owner.

This Warranty is in lieu of all other expressed warranties or liabilities. Any implied warranties, including any implied warranty of merchantability, shall be limited to the duration of this written warranty. No person or representative is authorized to assume, for Dakota Digital, any liability other than expressed herein in connection with the sale of this product.



**4510 W. 61st St. North**  
**Sioux Falls, SD 57107**  
[www.dakotadigital.com](http://www.dakotadigital.com)  
[dakotasupport@dakotadigital.com](mailto:dakotasupport@dakotadigital.com)

Phone (605) 332-6513  
Fax (605) 339-4106

© Copyright 2022 - Dakota Digital