

# ***Dakota Digital***

## DGS-4 GEAR SHIFT INDICATOR

### **Operation:**

The DGS-4 gear indicator unit works with Dakota Digital's gear position sending units (such as the GSS-1000). The gear sending unit should be setup to for one wire mode (see manual for gear sender). The DGS unit will then display a letter or number indicating the current gear.

The DGS-4 also has 4 additional indicators. These are, left and right turn signal, high beam indicator, and a miscellaneous warning light.

### **Setup:**

The wiring chart below describes the color code of the supplied harness. All inputs are +12v.

<b>Color</b>	<b>Purpose</b>
Purple	High beam indicator
Wht/Blk	Warning (negative input)
Wht/Red	Warning (positive input)
Green	Right turn signal
Orange	Left turn signal
Blue	Dim
Yellow	Gear data
Black	GND
Red	Ignition

The warning indicator has two possible modes of operation:

For a +12v activated warning signal, connect the White/Black wire to ground and connect the White/Red wire to the warning signal wire.

For a ground activated warning signal, connect the White/Red wire to +12v and connect the White/Black wire to the warning signal wire.

The yellow wire should be connected to the one wire signal terminal on the gear sender unit. The gear sender needs to be setup to use one wire mode or the indicator will not work properly.

### **Mounting:**

The DGS-4 requires an oval cut out that is about 2-5/16" x 1-1/16". It should be inserted into the opening from the front and the U-clamp will be installed from the back. Tighten the two nuts on the U-clamp so that the display is secure. Figure 1 shows the required cut out for the display. Figure 2 shows how the display mounts.

***Dakota Digital***

4510 W. 61<sup>st</sup> St. N., Sioux Falls, SD 57107  
Phone: (605) 332-6513 FAX: (605) 339-4106  
[www.dakotadigital.com](http://www.dakotadigital.com)

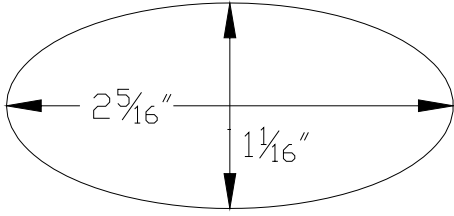

dash cut out

Figure 1

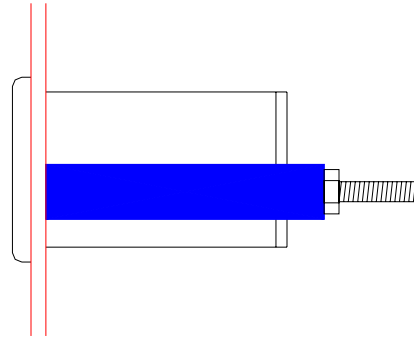

Figure 2

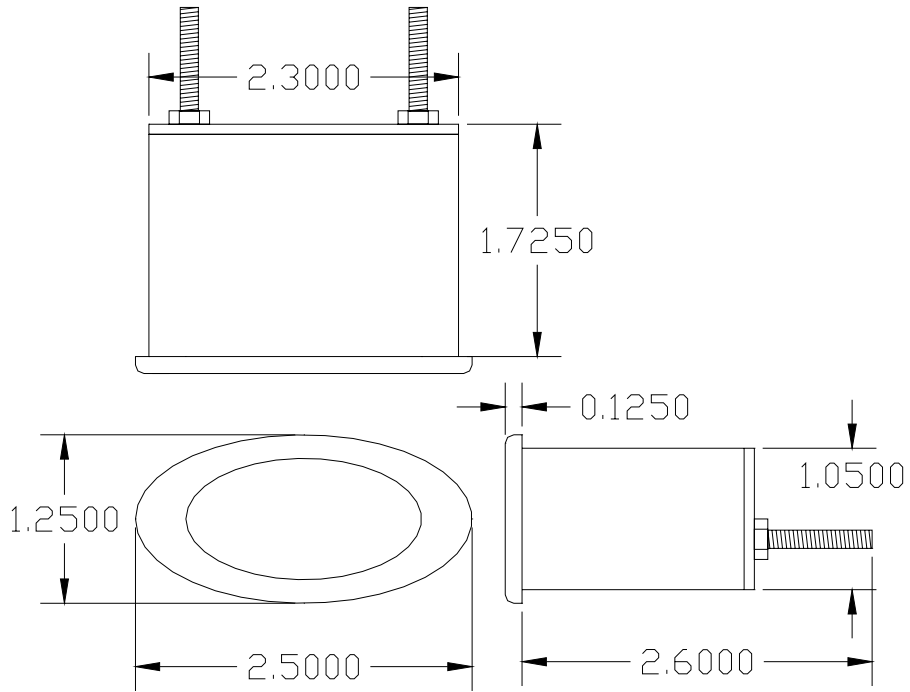

Figure 3

## TROUBLESHOOTING

PROBLEM	CAUSE	SOLUTION
Display reads --	Gear data (yellow wire) is shorted to ground or 12v or broken.	Check wire for places it is pinched or broken. Relocate pinched wire and repair breaks or bare spots.
	Gear sender unit not setup for one wire operation.	Set up the gear sender to send a one wire signal instead of wire per gear mode (see gear sender manual.)
Display reads 'E'	Error signal is sent from gear sender.	(See gear sender manual)
Warning indicator doesn't light	One of the wires for warning indicator are not connected.	BOTH wires of the warning indicator must be used for it to light. For high activated warning, Wht/Red goes to warning signal and Wht/Blk MUST go to ground. For ground activated signal, Wht/Blk goes to signal and Wht/Red MUST go to +12v

### WARRANTY

All DAKOTA DIGITAL instruments are warranted free of defects in material and workmanship for 2 years from the date of purchase. In the event of a problem with one of our products within the warranty period, DAKOTA DIGITAL will replace or repair the instrument at no charge. (The decision to repair or replace is solely that of DAKOTA DIGITAL. DAKOTA DIGITAL is not responsible for shipping costs of products returned under warranty or for labor charges for product installation and removal.) This warranty becomes invalid if the product is misused, altered or installed incorrectly.

**For warranty coverage, you must first call to receive an RMA#.** Ship the product transportation prepaid via UPS or insured Parcel Post. A copy of the original invoice or dated bill of sale along with a description of the defect is also required. Make sure that the RMA number is clearly visible on the outside of the package as well as inside on the paper work.

The above warranties, both expressed and implied, do not cover damages caused by improper installation, misuse, abuse, fire, unauthorized modifications, floods or acts of God, or reimbursement of customer or shop time. The extent of the warranty is limited only to the product and does not cover any loss or damage to vehicle, equipment, or non-DAKOTA DIGITAL products.

### SERVICE AND REPAIR

DAKOTA DIGITAL offers complete service and repair of its product line. In addition, technical consultation is available to help you work through any questions or problems you may be having installing one of our units.

Should you ever need to send the unit back for repairs, please package the product in a good quality box along with plenty of packing material. Ship the product by UPS or insured Parcel Post. Be sure to include your RMA#, a complete description of the problem, your full name and address (street address preferred), and a telephone number where you can be reached during the day. **A return authorization number (RMA#) for products being return for repair is required.** Do not send any money. We will bill you for the repair charges.

# ***Dakota Digital***

4510 W. 61ST St. N., Sioux Falls, SD 57107  
 Phone: (605) 332-6513 FAX: (605) 339-4106  
[www.dakotadigital.com](http://www.dakotadigital.com)  
[dakotasupport@dakotadigital.com](mailto:dakotasupport@dakotadigital.com)