

Dakota Digital

DSL-1 rev. D DIESEL TACH INTERFACE UNIT

This unit can provide a tachometer signal to drive a standard ignition system tachometer. The input signal can be from a tachometer output from the alternator or from a gear tooth sensor reading the flywheel teeth. Switch #3 selects which type of conversion is done.

SW #3	Sig In	OUT1	OUT2	OUT3	OUT4	OUT5
ON	Flywheel	Hi-Volt 8	8 cyl	4 cyl	Not used	Not used
OFF	Alternator	Hi-Volt 8	8 cyl	4 cyl	Not used	Not used

ALTERNATOR TACH INTERFACE UNIT Switch #3 OFF

This unit will accept a signal from the 'W' terminal on an alternator and convert it into a tachometer signal for an 8 cylinder ignition system tachometer. The unit is adjustable to allow for the different numbers of poles on the alternator as well as different pulley sizes on the engine and alternator. Calibration should be done using a light tach or another known reference for engine speed.

The DSL-1 C has an adjustable range of 4.00 to 0.25 which is broken into 512 steps. Calibration is set using the DIP programming switches according to the chart on the following page. Wiring instructions are provided below.

Determining required calibration ratio.

First set the switches to a cal ratio of 1.00. This is done by setting switch #3 on and #4 off and then holding both the UP and DN switches while turning the key on. Next determine how far the tachometer is off using a known reference.

Begin with the switches as follows and then determine how far of the calibration is.

1	2	3	4
OFF	ON	OFF	ON

The new calibration ratio to make the tach read correctly is found using the equation below.

$$(\text{Actual RPM}) \div (\text{Tachometer reading}) = \text{calibration ratio}$$

Use the directions on page 3 to adjust the tachometer reading.

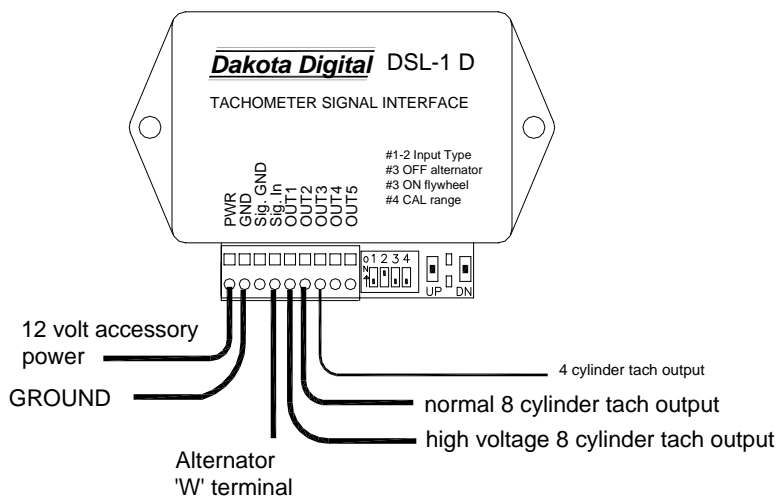

FLYWHEEL TACH INTERFACE UNIT

Switch #3 ON

Convert a signal from a flywheel gear-tooth sensor to an ignition tachometer signal.

For using a standard 4-6-8 cylinder tachometer on a diesel engine, the DSL-1 C can convert a flywheel sensor signal into an 8-cylinder gas ignition signal. Calibration is accomplished by counting the number of teeth on the flywheel or using another tachometer as a reference. The number of teeth are listed in the calibration table under the heading "teeth". When switch #4 is ON, the tooth count will cover from 32 to 127 teeth (the chart lists settings for 64-127). Then switch #4 is OFF, the tooth count will cover from 128-510 teeth (the chart lists settings for 128-255). An inductive, gear-tooth sensor such as VDO part #340 020 should be mounted so the teeth pass by the end of the sensor. The GND terminal on the DSL-1 C should be connected to a good ground as well as to one of the terminals on the gear-tooth sensor. The SIG IN terminal will connect to the other terminal from the sensor. Connect the PWR terminal to 12V accessory power. OUT2 will provide the signal to the tachometer. Set the programming switches as follows:

1	2	3	4
OFF	ON	ON	OFF

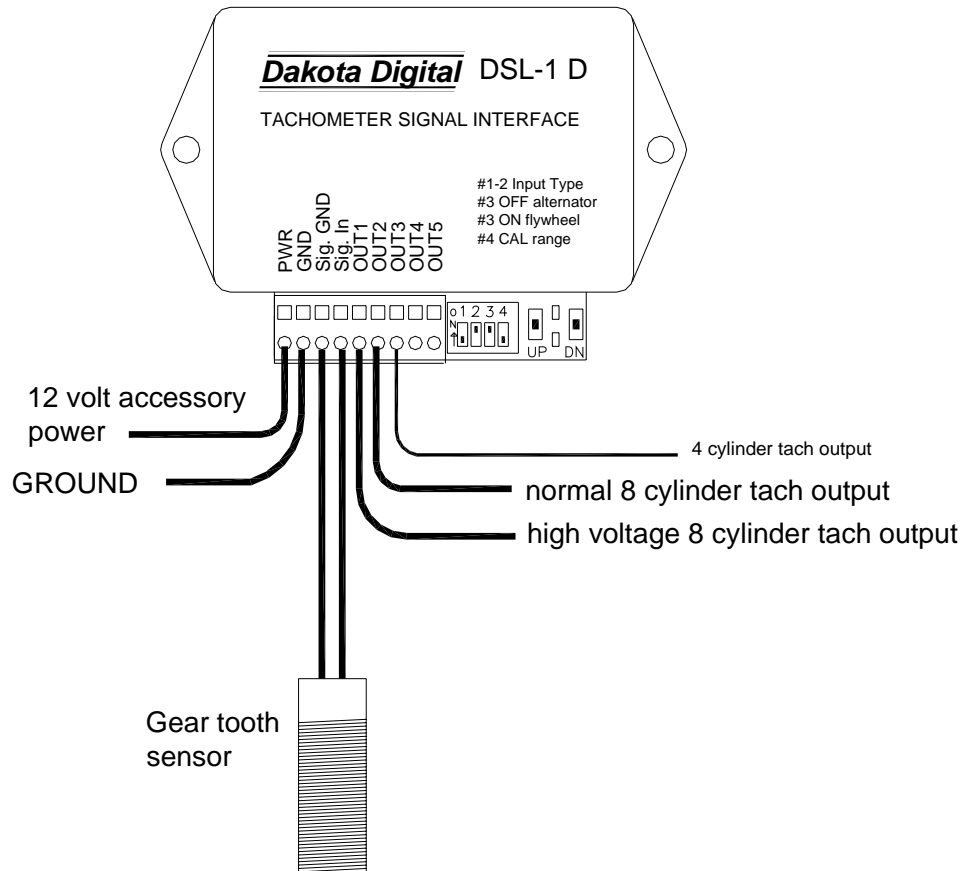

Setup and diagnostic lights

RED	GREEN	Status
OFF	OFF	Power off.
OFF	ON	Power on, no sensor signal present
OFF	Flashing	Power on, sensor signal present
ON	Flashing	Coarse calibration adjustment mode
Flashing	ON	Fine calibration adjustment mode
ON	ON	Both switches held to preset cal
ON	OFF	One switch is being held to enter setup mode

Calibration

Adjust with engine running: To increase the tachometer reading, press and hold the UP push button switch. To decrease the tachometer reading, press and hold the DN push button switch. If you cannot get the tachometer to read fast enough, make sure that setup switch #4 is ON. If you cannot get the tachometer to read slow enough, make sure that setup switch #4 is OFF or move to a different output.

Preset or adjust with engine off: The calibration table is listed at the back of the installation manual. There is a coarse adjust setting and a fine adjust setting.

To check or change the coarse adjust setting:

1. Begin with the key off.
2. Press and hold the UP switch while turning the key on. The RED light should be on.
3. Release the UP switch. The GREEN light will begin flashing the current coarse setting. It will flash the current setting, wait, flash the current setting, wait, etc.
4. To increase the setting, press and release the UP switch. To decrease the setting, press and release the DN switch.
5. When the GREEN light flashes the correct number of times, turn the key off.

To check or change the fine adjust setting:

1. Begin with the key off.
2. Press and hold the DN switch while turning the key on. The RED light should be on.
3. Release the DN switch. The GREEN light will come on steady and the RED light will begin flashing the current fine setting. It will flash the current setting, wait, flash the current setting, wait, etc.
4. To increase the setting, press and release the UP switch. To decrease the setting, press and release the DN switch.
5. When the RED light flashes the correct number of times, turn the key off.

Quick preset: Hold both UP and DN push buttons while turning the key on.

Set to x1.004: Turn setup switch #3 off, #4 on, hold both buttons while turning key on.

Set to x1.000: Turn setup switch #3 off, #4 off, hold both buttons while turning key on.

Set to x2.0: Turn setup switch #3 on, #4 on, hold both buttons while turning key on.

Set to x0.5: Turn setup switch #3 on, #4 off, hold both buttons while turning key on.

Cal Hi represents switch #2 ON. Cal Lo represents switch #2 OFF. For Teeth 128-255, sw #2 OFF. For Teeth 64-127, sw #2 ON.

coarse	fine	Cal Hi	Cal Lo	teeth	coarse	fine	Cal Hi	Cal Lo	teeth	coarse	fine	Cal Hi	Cal Lo	teeth	coarse	fine	Cal Hi	Cal Lo	teeth
16	16	4.000	1.000	128	12	16	2.667	0.667	192	8	16	2.000	0.500	64	4	16	1.333	0.333	96
16	15	3.969	0.992	129	12	15	2.653	0.663	193	8	15	1.984	0.496	65	4	15	1.326	0.332	97
16	14	3.938	0.985	130	12	14	2.639	0.660	194	8	14	1.969	0.492	65	4	14	1.320	0.330	97
16	13	3.908	0.977	131	12	13	2.626	0.656	195	8	13	1.954	0.489	66	4	13	1.313	0.328	98
16	12	3.879	0.970	132	12	12	2.612	0.653	196	8	12	1.939	0.485	66	4	12	1.306	0.327	98
16	11	3.850	0.962	133	12	11	2.599	0.650	197	8	11	1.925	0.481	67	4	11	1.299	0.325	99
16	10	3.821	0.955	134	12	10	2.586	0.646	198	8	10	1.910	0.478	67	4	10	1.293	0.323	99
16	9	3.793	0.948	135	12	9	2.573	0.643	199	8	9	1.896	0.474	68	4	9	1.286	0.322	100
16	8	3.765	0.941	136	12	8	2.560	0.640	200	8	8	1.882	0.471	68	4	8	1.280	0.320	100
16	7	3.737	0.934	137	12	7	2.547	0.637	201	8	7	1.869	0.467	69	4	7	1.274	0.318	101
16	6	3.710	0.928	138	12	6	2.535	0.634	202	8	6	1.855	0.464	69	4	6	1.267	0.317	101
16	5	3.683	0.921	139	12	5	2.522	0.631	203	8	5	1.842	0.460	70	4	5	1.261	0.315	102
16	4	3.657	0.914	140	12	4	2.510	0.627	204	8	4	1.829	0.457	70	4	4	1.255	0.314	102
16	3	3.631	0.908	141	12	3	2.498	0.624	205	8	3	1.816	0.454	71	4	3	1.249	0.312	103
16	2	3.606	0.901	142	12	2	2.485	0.621	206	8	2	1.803	0.451	71	4	2	1.243	0.311	103
16	1	3.580	0.895	143	12	1	2.473	0.618	207	8	1	1.790	0.448	72	4	1	1.237	0.309	104
15	16	3.556	0.889	144	11	16	2.462	0.615	208	7	16	1.778	0.444	72	3	16	1.231	0.308	104
15	15	3.531	0.883	145	11	15	2.450	0.612	209	7	15	1.766	0.441	73	3	15	1.225	0.306	105
15	14	3.507	0.877	146	11	14	2.438	0.610	210	7	14	1.753	0.438	73	3	14	1.219	0.305	105
15	13	3.483	0.871	147	11	13	2.427	0.607	211	7	13	1.741	0.435	74	3	13	1.213	0.303	106
15	12	3.459	0.865	148	11	12	2.415	0.604	212	7	12	1.730	0.432	74	3	12	1.208	0.302	106
15	11	3.436	0.859	149	11	11	2.404	0.601	213	7	11	1.718	0.430	75	3	11	1.202	0.300	107
15	10	3.413	0.853	150	11	10	2.393	0.598	214	7	10	1.707	0.427	75	3	10	1.196	0.299	107
15	9	3.391	0.848	151	11	9	2.381	0.595	215	7	9	1.695	0.424	76	3	9	1.191	0.298	108
15	8	3.368	0.842	152	11	8	2.370	0.593	216	7	8	1.684	0.421	76	3	8	1.185	0.296	108
15	7	3.346	0.837	153	11	7	2.359	0.590	217	7	7	1.673	0.418	77	3	7	1.180	0.295	109
15	6	3.325	0.831	154	11	6	2.349	0.587	218	7	6	1.662	0.416	77	3	6	1.174	0.294	109
15	5	3.303	0.826	155	11	5	2.338	0.584	219	7	5	1.652	0.413	78	3	5	1.169	0.292	110
15	4	3.282	0.821	156	11	4	2.327	0.582	220	7	4	1.641	0.410	78	3	4	1.164	0.291	110
15	3	3.261	0.815	157	11	3	2.317	0.579	221	7	3	1.631	0.408	79	3	3	1.158	0.290	111
15	2	3.241	0.810	158	11	2	2.306	0.577	222	7	2	1.620	0.405	79	3	2	1.153	0.288	111
15	1	3.220	0.805	159	11	1	2.296	0.574	223	7	1	1.610	0.403	80	3	1	1.148	0.287	112
14	16	3.200	0.800	160	10	16	2.286	0.571	224	6	16	1.600	0.400	80	2	16	1.143	0.286	112
14	15	3.180	0.795	161	10	15	2.276	0.569	225	6	15	1.590	0.398	81	2	15	1.138	0.284	113
14	14	3.160	0.790	162	10	14	2.265	0.566	226	6	14	1.580	0.395	81	2	14	1.133	0.283	113
14	13	3.141	0.785	163	10	13	2.256	0.564	227	6	13	1.571	0.393	82	2	13	1.128	0.282	114
14	12	3.122	0.780	164	10	12	2.246	0.561	228	6	12	1.561	0.390	82	2	12	1.123	0.281	114
14	11	3.103	0.776	165	10	11	2.236	0.559	229	6	11	1.552	0.388	83	2	11	1.118	0.279	115
14	10	3.084	0.771	166	10	10	2.226	0.557	230	6	10	1.542	0.386	83	2	10	1.113	0.278	115
14	9	3.066	0.766	167	10	9	2.216	0.554	231	6	9	1.533	0.383	84	2	9	1.108	0.277	116
14	8	3.048	0.762	168	10	8	2.207	0.552	232	6	8	1.524	0.381	84	2	8	1.103	0.276	116
14	7	3.030	0.757	169	10	7	2.197	0.549	233	6	7	1.515	0.379	85	2	7	1.099	0.275	117
14	6	3.012	0.753	170	10	6	2.188	0.547	234	6	6	1.506	0.376	85	2	6	1.094	0.274	117
14	5	2.994	0.749	171	10	5	2.179	0.545	235	6	5	1.497	0.374	86	2	5	1.089	0.272	118
14	4	2.977	0.744	172	10	4	2.169	0.542	236	6	4	1.488	0.372	86	2	4	1.085	0.271	118
14	3	2.960	0.740	173	10	3	2.160	0.540	237	6	3	1.480	0.370	87	2	3	1.080	0.270	119
14	2	2.943	0.736	174	10	2	2.151	0.538	238	6	2	1.471	0.368	87	2	2	1.076	0.269	119
14	1	2.926	0.731	175	10	1	2.142	0.536	239	6	1	1.463	0.366	88	2	1	1.071	0.268	120
13	16	2.909	0.727	176	9	16	2.133	0.533	240	5	16	1.455	0.364	88	1	16	1.067	0.267	120
13	15	2.893	0.723	177	9	15	2.124	0.531	241	5	15	1.446	0.362	89	1	15	1.062	0.266	121
13	14	2.876	0.719	178	9	14	2.116	0.529	242	5	14	1.438	0.360	89	1	14	1.058	0.264	121
13	13	2.860	0.715	179	9	13	2.107	0.527	243	5	13	1.430	0.358	90	1	13	1.053	0.263	122
13	12	2.844	0.711	180	9	12	2.098	0.525	244	5	12	1.422	0.356	90	1	12	1.049	0.262	122
13	11	2.829	0.707	181	9	11	2.090	0.522	245	5	11	1.414	0.354	91	1	11	1.045	0.261	123
13	10	2.813	0.703	182	9	10	2.081	0.520	246	5	10	1.407	0.352	91	1	10	1.041	0.260	123
13	9	2.798	0.699	183	9	9	2.073	0.518	247	5	9	1.399	0.350	92	1	9	1.036	0.259	124
13	8	2.783	0.696	184	9	8	2.065	0.516	248	5	8	1.391	0.348	92	1	8	1.032	0.258	124
13	7	2.768	0.692	185	9	7	2.056	0.514	249	5	7	1.384	0.346	93	1	7	1.028	0.257	125
13	6	2.753	0.688	186	9	6	2.048	0.512	250	5	6	1.376	0.344	93	1	6	1.024	0.256	125
13	5	2.738	0.684	187	9	5	2.040	0.510	251	5	5	1.369	0.342	94	1	5	1.020	0.255	126
13	4	2.723	0.681	188	9	4	2.032	0.508	252	5	4	1.362	0.340	94	1	4	1.016	0.254	126
13	3	2.709	0.677	189	9	3	2.024	0.506	253	5	3	1.354	0.339	95	1	3	1.012	0.253	127
13	2	2.695	0.674	190	9	2	2.016	0.504	254	5	2	1.347	0.337	95	1	2	1.008	0.252	127
13	1	2.681	0.670	191	9	1	2.008	0.502	255	5	1	1.340	0.335	96	1	1	1.004	0.251	128

Trouble shooting guide

<u>Problem</u>	<u>Possible Cause</u>	<u>Solution</u>
Tachometer will not work. GREEN light off.	No power to DSL1.	Check the power and ground terminals on the DSL-1. Should be 11-15 V dc.
Tachometer will not work. GREEN light on steady.	No input signal.	Test for 1-20 volts AC at the signal in terminal with the wheels spinning.
	DSL-1 set for wrong input type.	Turn switch #1 ON and #2 OFF.
	Grounding interference.	Make sure both the speed sensor and DSL-1 are grounded at the same point.
Tachometer will not work. GREEN light flashing.	Wrong output type.	Try switching from normal output to the high voltage output.
Tachometer will not read at low rpm.	DSL-1 set for wrong input type.	Turn switch #2 OFF.
	Tach signal is too low.	Check sensor connections for ground problems or shorts. Test the ground connection between DSL-1 and sensor. Check for another device loading down the sensor.
Tachometer will not read at high rpm.	DSL-1 set for wrong input type.	Turn switch #2 ON.
Tachometer will read when the engine is off	Ignition wire too close to sensor signal wire.	Route the sensor signal and ignition or injector wires away from each other to avoid interference.
	Signal In and OUT wires routed too close.	Route the input and output wires away from each other to avoid feedback.
	Ground interference.	Make sure the speed sensor and SGI-5 are grounded together.
	Sensitivity set incorrectly	Turn switch #2 ON.

Tech Support

You can contact us with any questions you may have by phone, fax, or email.

Dakota Digital

4510 W. 61ST St. N., Sioux Falls, SD 57107
Phone: (605) 332-6513 FAX: (605) 339-4106

www.dakotadigital.com
dakotasupport@dakotadigital.com

©Copyright 2004 Dakota Digital Inc.