

Dakota Digital

Dual Intensity LED Marker Lights

LDM-CA01 LDM-CR01
LDM-CA25 LDM-CR25
LDM-CA50 LDM-CR50

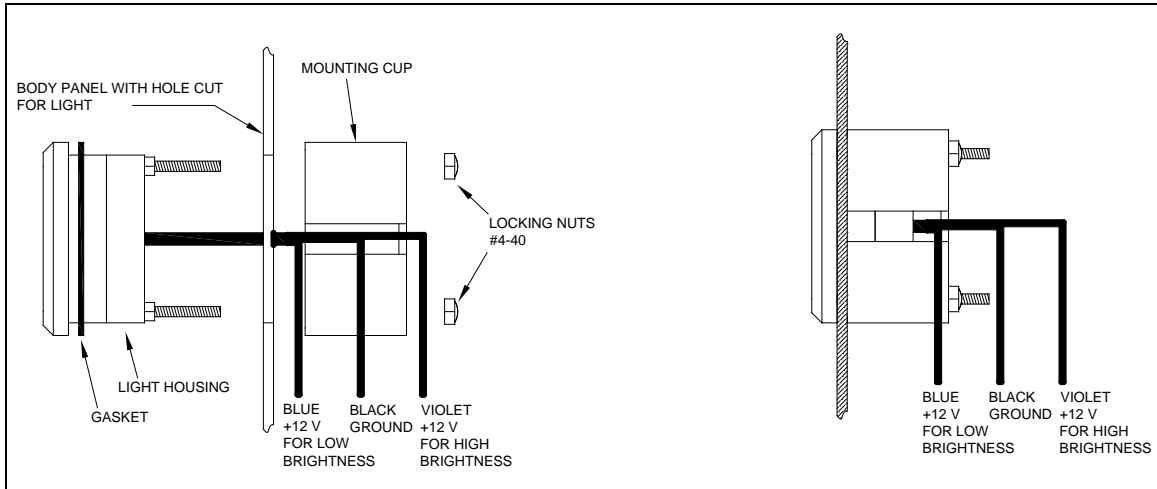

Thank you for purchasing Dakota Digital LED marker lights, please take a moment to inventory your parts and installation hardware. The Marker lights are shipped with all of the necessary components to mount them. As shown in Figure 1 above:

- 2 Light assemblies
- 2 Mounting cups
- 2 Gaskets
- 3 Locking # 4- 40 nuts
- 6 Push-lock connectors

Installation

1. Determine mounting location and position for the lights. Verifying there is enough room behind the panel/body for the lights and a safe place to route the wires where they will not be cut or wear due to vibrations/movement.
2. Cut out the appropriate template from the 3 styles provided and tape it to the body in the desired location. Using the template as a guide, cut the hole using the appropriate tools. Start by cutting just inside the black line, test fitment, and trim as necessary for a snug fit. Be extremely careful to avoid cutting any material outside of the gray lines as this would be visible.
3. Use the hardware supplied to secure the marker light into the body. First, install the gasket around the light, then feed the wires through the hole and slide the marker light into place. Place the clamp over the studs and secure it using the supplied lock nuts. Tighten until snug. See the figure above if you have any questions.

4. The marker lights have two brightness levels, they can be connected to a keyed power source, along with another switched source to flash or enable the second brightness level.

The connections are:

- BLACK - Ground, connect to a good chassis ground or negative side of battery
- BLUE - Low Brightness, connect to keyed +12 V for running light operation
- VIOLET - High Brightness, connect to an auxiliary switched +12 V source, or a flasher for flashing operation

Note: If only one brightness level is desired, connect the black ground wire and the +12 V wire for the desired brightness level, leaving the remaining wire disconnected.

Use the supplied moisture resistant pigtail connectors to attach the wires from the new LED assembly to the existing vehicle harness, solder may also be used. Insert the appropriate wire from vehicle harness and mating LED assembly wire into a connector and crimp.

The correct crimp method for the supplied connectors is:

- 1.) Insert **UNSTRIPPED** wires into the connector and ensure they are all the way in by observing the clear bottom of the connector to see the wires are touching the end.
- 2.) Use pliers to push the blue cap down flush with the edge of the clear body, completing the connection. The connection will only be correct if pressed firmly down with pliers.

SERVICE AND REPAIR

DAKOTA DIGITAL offers complete service and repair of its product line. In addition, technical consultation is available to help you work through any questions or problems you may be having installing one of our products. Please read through the Troubleshooting Guide. There, you will find the solution to most problems. **Should you ever need to send the unit back for repairs, please call our technical support line, (605) 332-6513, to request a Return Merchandise Authorization number.** Package the product in a good quality box along with plenty of packing material. Ship the product by UPS or insured Parcel Post. Be sure to include the RMA number on the package, and include a complete description of the problem with RMA number, your full name and address (street address preferred), and a telephone number where you can be reached during the day. Any returns for warranty work must include a copy of the dated sales receipt from your place of purchase. Send no money. We will bill you after repair.

Dakota Digital 24 Month Warranty

DAKOTA DIGITAL warrants to the ORIGINAL PURCHASER of this product that should it, under normal use and condition, be proven defective in material or workmanship within 24 MONTHS FROM THE DATE OF PURCHASE, such defect(s) will be repaired or replaced at Dakota Digital's option.

This warranty does not cover nor extend to damage to the vehicle's systems, and does not cover removal or reinstallation of the product. This Warranty does not apply to any product or part thereof which in the opinion of the Company has been damaged through alteration, improper installation, mishandling, misuse, neglect, or accident.

This Warranty is in lieu of all other expressed warranties or liabilities. Any implied warranties, including any implied warranty of merchantability, shall be limited to the duration of this written warranty. Any action for breach of any warranty hereunder, including any implied warranty of merchantability, must be brought within a period of 24 months from date of original purchase. No person or representative is authorized to assume, for Dakota Digital, any liability other than expressed herein in connection with the sale of this product.

Dakota Digital

4510 W. 61ST St. N., Sioux Falls, SD 57107
Phone: (605) 332-6513 FAX: (605) 339-4106

www.dakotadigital.com
dakotasupport@dakotadigital.com