



SIM-1 SPEED RECALIBRATION UNIT FOR HARLEY DAVIDSON ELECTRIC SPEEDOMETERS

Changing the gearing or tire size on a motorcycle will make the speed reading incorrect. The SIM-1 will allow you to adjust an electronic speedometer, with stock electric speed sensors, back to the correct reading.

The SIM-1 has an adjustable range of correction from x2.84 times (more than double) to x0.502 times (half). Calibration is set using the two push button switches. Press the UP button to increase the speed. Press the DOWN button to decrease the speed. The unit has an internal memory which stores the calibration when the bike is turned off, or if the unit is unplugged for any work.

1996-2006 Harleys 3-pin triangular Deutsch connectors

Connection is as follows:

1. Locate the three pin, triangular connector between the speedometer and transmission speed sensor. (*image 1*)
2. Unplug the connector.
3. Plug the SIM-1 into the two mating connectors. The SIM-1 will now be in between the speedometer and transmission speed sensor. (*image 2*)
4. Calibrate the speedometer. (see steps below)
5. Secure the SIM-1 into the harness on the bike so it is not hanging loose. Wire ties work well for this. (*image 3*)



Image 1



Image 2



Image 3

Calibration is as follows:

1. Follow a vehicle going at a set speed or time yourself driving one mile so you know what your speed should be. A dyno or GPS are also great ways to reference speed.
2. Press and hold the UP or DOWN button while you are driving to change the speedometer reading until the speedometer is correct. *The bike must be moving in order to adjust the speedometer.*
3. After the SIM-1 has detected that no buttons have been pressed for about 10 seconds, the new calibration is stored.

*2004 and newer Harley Davidson Motorcycles make use of a data bus to send speed information to the speedometer. Due to this fact, the SIM-1 needs to correct speed information before it goes into the ECM. In order to correct a speedometer on a 2004 or newer bike, the SIM-1 needs to be connected between the speed sensor and the ECM.

2004-current Sportsters and 2007-current all models: Cut and splice the wires and solder the SIM-1 in before the ECM. This is required due to the different style of connector on the speed sensor.

Locate the speed sensor wires coming from the sensor. The speed sensor is below the battery at the back of the transmission almost directly centered in the bike. Once located, follow the wires up to the ECM. At an accessible point, cut the wires and solder in the SIM-1 as indicated in the picture on the next page. You must also make the cut prior to where the white/green wire is T-ed to the cruise control module on 2007 model bikes with cruise, this is usually about 3- 4" after the speed sensor plug at the sensor. (see wiring diagrams on next page)

Dakota Digital 24 Month Warranty

DAKOTA DIGITAL warrants to the ORIGINAL PURCHASER of this product that should it, under normal use and condition, be proven defective in material or workmanship within 24 MONTHS FROM THE DATE OF PURCHASE, such defect(s) will be repaired or replaced at Dakota Digital's option.

This warranty does not cover nor extend to damage to the vehicle's systems, and does not cover removal or reinstallation of the product. This Warranty does not apply to any product or part thereof which in the opinion of the Company has been damaged through alteration, improper installation, mishandling, misuse, neglect, or accident.

This Warranty is in lieu of all other expressed warranties or liabilities. Any implied warranties, including any implied warranty of merchantability, shall be limited to the duration of this written warranty. Any action for breach of any warranty hereunder, including any implied warranty of merchantability, must be brought within a period of 24 months from date of original purchase. No person or representative is authorized to assume, for Dakota Digital, any liability other than expressed herein in connection with the sale of this product.

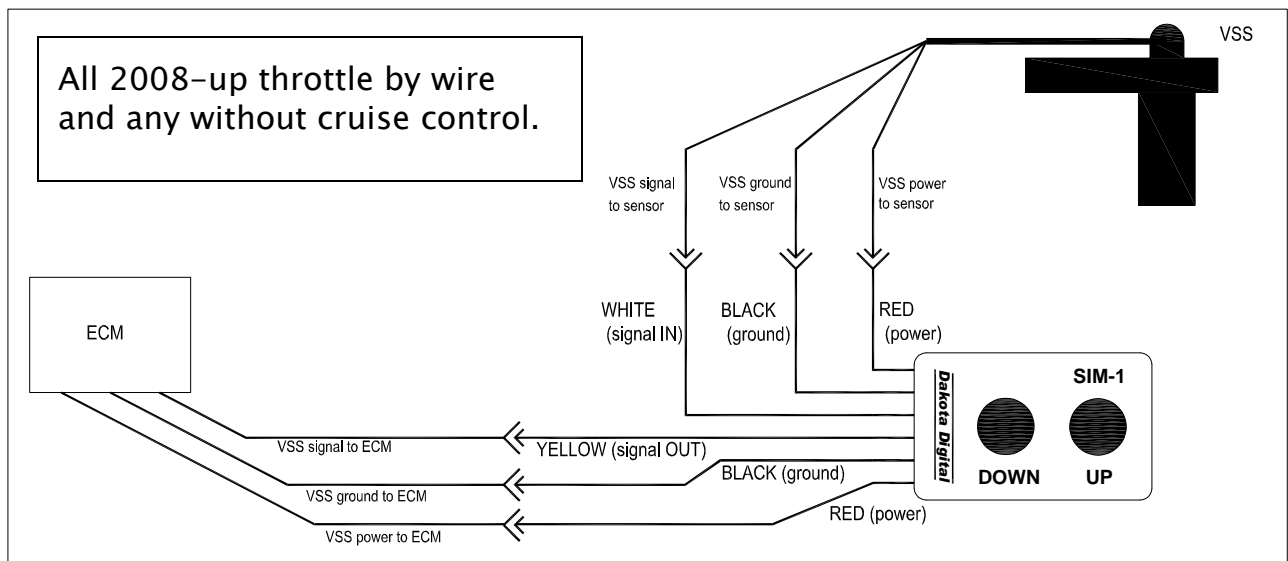
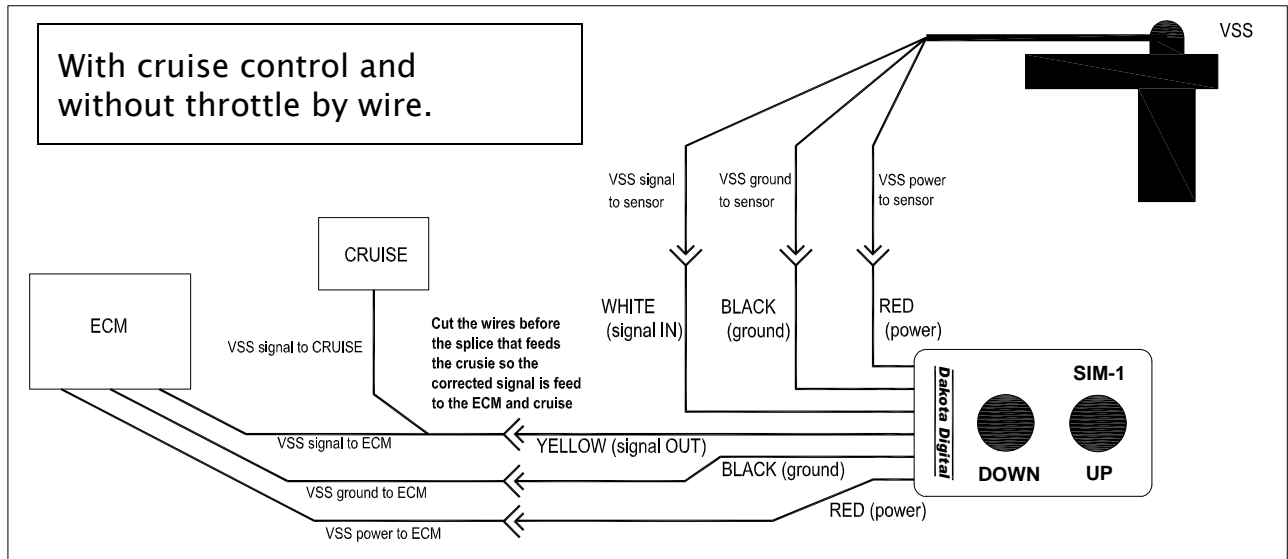

Common VSS wire color codes found on various models:

	VSS ground	VSS signal	VSS power
Softail	Black/Green	White/Green or Lt Green/Yellow	Red/White
Dyna	Black or Black/Green	White/Green	Red/White
Touring	Black/Green or Black/Yellow	White/Green	Red/White or Brown/Orange
Sportster	Black	Black/Blue	Black/Red



4510 W. 61st St. North
Sioux Falls, SD 57107
www.dakotadigital.com

Phone (605) 332-6513
Fax (605) 339-4106

dakotasupport@dakotadigital.com Copyright 2011 - Dakota Digital, Inc.