

Dakota Digital

CMD-X

COMMANDER SERIES REMOTE CONTROL ENTRY SYSTEM

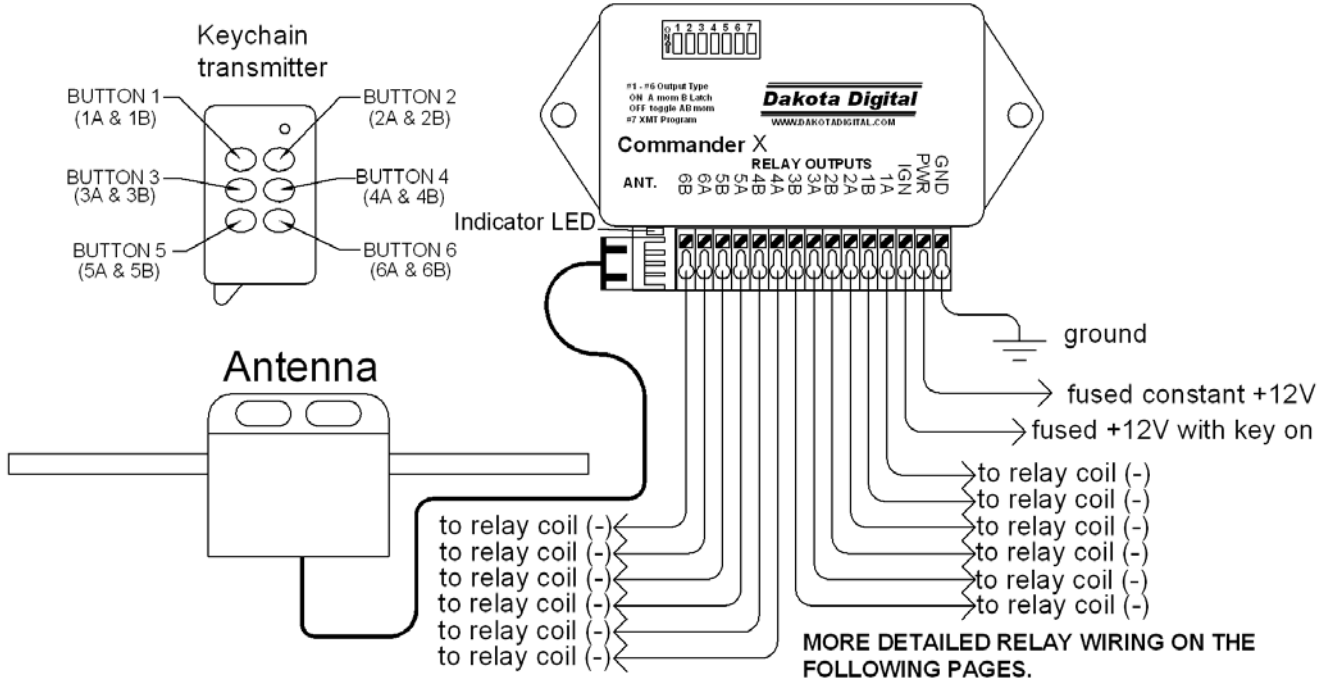

Terminal	Connection
GND	chassis ground
PWR	to constant +12V power
IGN	to key on +12V power
1A	grounding(-) output to relay coil
1B	grounding(-) output to relay coil
2A	grounding(-) output to relay coil
2B	grounding(-) output to relay coil
3A	grounding(-) output to relay coil
3B	grounding(-) output to relay coil
4A	grounding(-) output to relay coil
4B	grounding(-) output to relay coil
5A	grounding(-) output to relay coil
5B	grounding(-) output to relay coil
6A	grounding(-) output to relay coil
6B	grounding(-) output to relay coil

Switch	Position	Output function
1	ON	1A momentary 1B latching
	OFF	1A and 1B are toggling momentary
2	ON	2A momentary 2B latching
	OFF	2A and 2B are toggling momentary
3	ON	3A momentary 3B latching
	OFF	3A and 3B are toggling momentary
4	ON	4A momentary 4B latching
	OFF	4A and 4B are toggling momentary
5	ON	5A momentary 5B latching
	OFF	5A and 5B are toggling momentary
6	ON	6A momentary 6B latching
	OFF	6A and 6B are toggling momentary

INTRODUCTION

Thank you for purchasing the CMD-X Commander from Dakota Digital. This, along with many other products that Dakota Digital has to offer, represent the latest in electronics technology for your street rod, classic car, truck, or custom vehicle.

The CMD-X package includes:

- Receiver/controller
- 2 key chain style transmitters
- 2 dual relay packs
- 2 single relay packs

The CMD-X can control nearly any configuration of auxiliary outputs through use of the provided external relays. The CMD-X has a total of twelve outputs that can be programmed for a momentary-on or latch-on and latch-off. Common applications include: power windows, electric door locks, power trunk, electric tonneau covers, tilt front ends, moon roof control, and other lights or motors.

A safety feature partially disables the system when the ignition is on to avoid the accidental opening of a door, or some other undesired function, during vehicle operation. With the ignition on, the only functions that are allowed to work are outputs 1A, 1B, 2A, and 2B. The ignition will disable all other outputs, and keep latched outputs at their current state, on or off.

ADDITIONAL TRANSMITTERS

The transmitters supplied with your remote system have a unique serial number coded into each one for security. Each unit can “learn” up to 7 transmitters. Lost or stolen transmitters are easily erased by simply reprogramming the remaining transmitters into the system again. Transmitters from other manufacturers, such as car alarm systems, will not work with the CMD-X.

RADIO FREQUENCY INTERFERENCE STATEMENT

FCC IDENTIFIER: KNF6TX

This device complies with part 15 of FCC rules. Operation is subject to the following two conditions: (1) This device may not cause harmful interference, and (2) This device must accept any interference received, including interference that may cause undesired operation.

INSTALLATION

The receiver should be mounted in the interior of the vehicle so that it is not exposed to moisture. It can be secured using the two mounting holes or with a double sided adhesive tape, such as Velcro. Power, ground, ignition, and all outputs are connected to the push-and-lock terminal strip along the front edge of the controller. The antenna plugs into the 3 pin connector, next to the terminal strip. The antenna should be mounted away from any power wires or motors higher up in the vehicle.

The connections to the main terminal strip are listed on Page 1. The unit only needs power and ground connected to operate. The others should be hooked up according to your application. The IGN terminal can be connect to a key on +12V source to disable outputs 3-6 to prevent accidental function while the key is on. The CMD-X should only be connected to a 12 volt battery for power and never solely to a battery charger.

All outputs are grounding, or negative, outputs designed to ONLY turn on external relays. NEVER DIRECTLY CONNECT A CMD-X OUTPUT TO A MOTOR, SOLENOID, LIGHTS, OR SIMILAR LOAD, INTERNAL CIRCUIT DAMAGE WILL RESULT. Figure 1 shows how to wire ground switched relays to outputs 1A – 6B shown on the first page. Single and dual relay packs can be used for the CMD-X outputs. Additional relay packs are available separately from Dakota Digital.

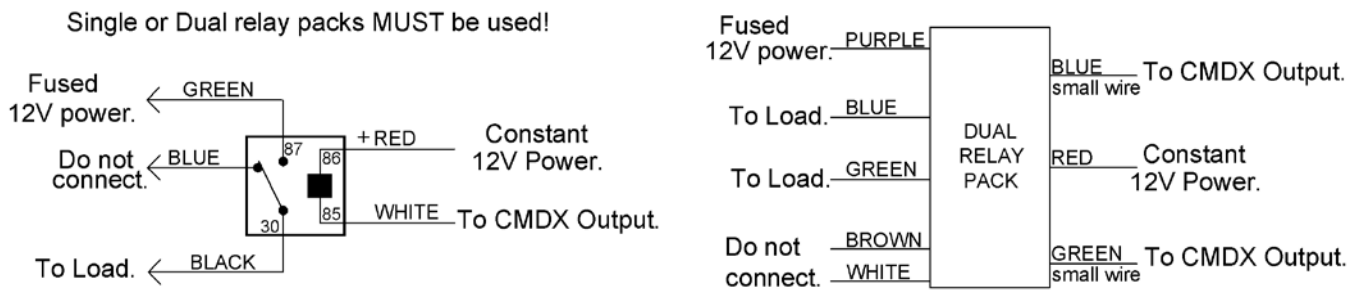
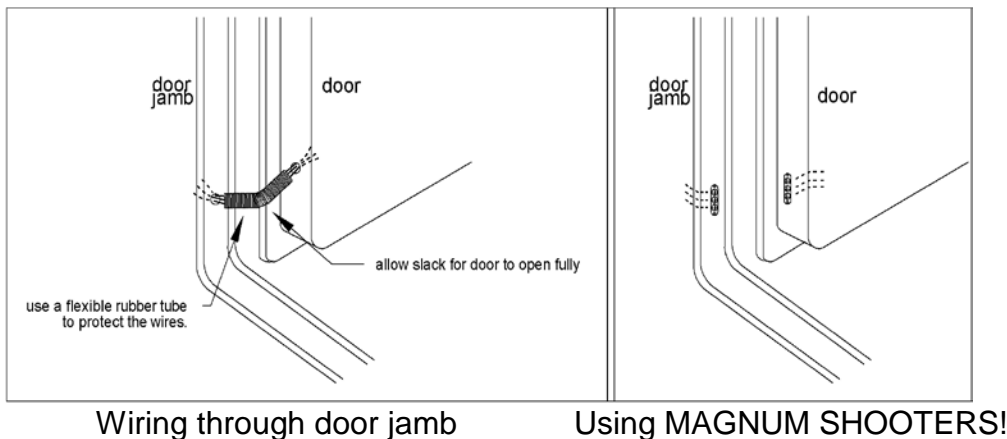

FIGURE 1 Wiring a high current relay (ground switched).

If wiring through the door jambs, consider **DAKOTA DIGITAL MAGNUM SHOOTERS** to eliminate having any wires running through your door jambs. Refer to the following diagrams for connection to your particular actuators and power windows.



The following pages of the manual show some common applications and how to wire relays to the CMD-X outputs. These are only suggestions and other relay configurations are possible depending on your application or device to be driven.

DOOR AND TRUNK LATCH WIRING.

Latches and latch actuators are not included in the kit. These are available separately. If door motors or solenoids are already mounted in the vehicle, the CMD-X system can be used to control them. **All outputs need to be wired through an external relay.** Latch motors and actuators also need to be connected to a **momentary** output, NEVER hook a latch actuator to a latching output or motor damage could result. All of the relays in Figure 2 are connected to 'A' outputs, or momentary outputs to ensure the latch motor is only powered while a button is pressed. Holding a button for an extended period of time could also damage latching motors.

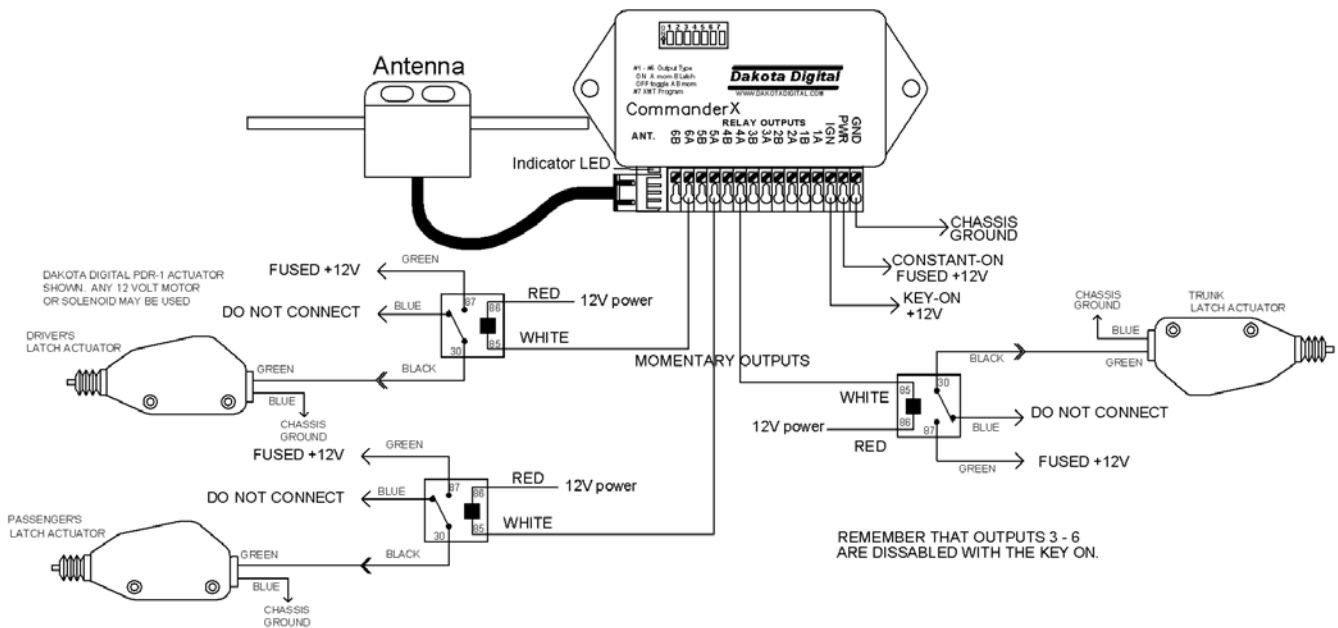

FIGURE 2 Door and trunk latch wiring diagram.

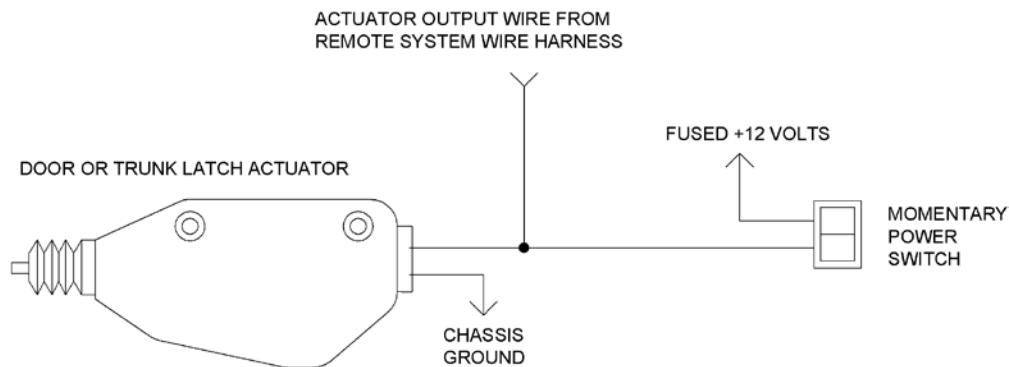

FIGURE 3 Wiring to control actuator with the remote and an inside switch.

POWER WINDOW WIRING

Power window regulators are not included with the remote system base kit. They are available separately from Dakota Digital. This remote system is designed to wire into existing power windows or installed at the same time as power windows are added to the vehicle. Use the diagram which matches the way your power windows are connected. The relays are designed to duplicate the function of the power window switch you are using and provide up and down window motion. The CMD-X should be set up for toggling momentary outputs, and A and B from one channel will be used for drivers side and another channel for the passengers.

Because the switch pin-out varies with different switch types and between different manufacturers, refer to your power window wiring instructions for window regulator and switch color code and pin location. The diagram below shows how to hook up the remote system to an existing power window harness. It is recommended that the power windows be first wired up to its own switches and wiring harness without the remote system. Once the power windows are working correctly with the supplied switches, then connect the remote system relay packs to the harness. This will simplify correcting any wiring problems that may show up.

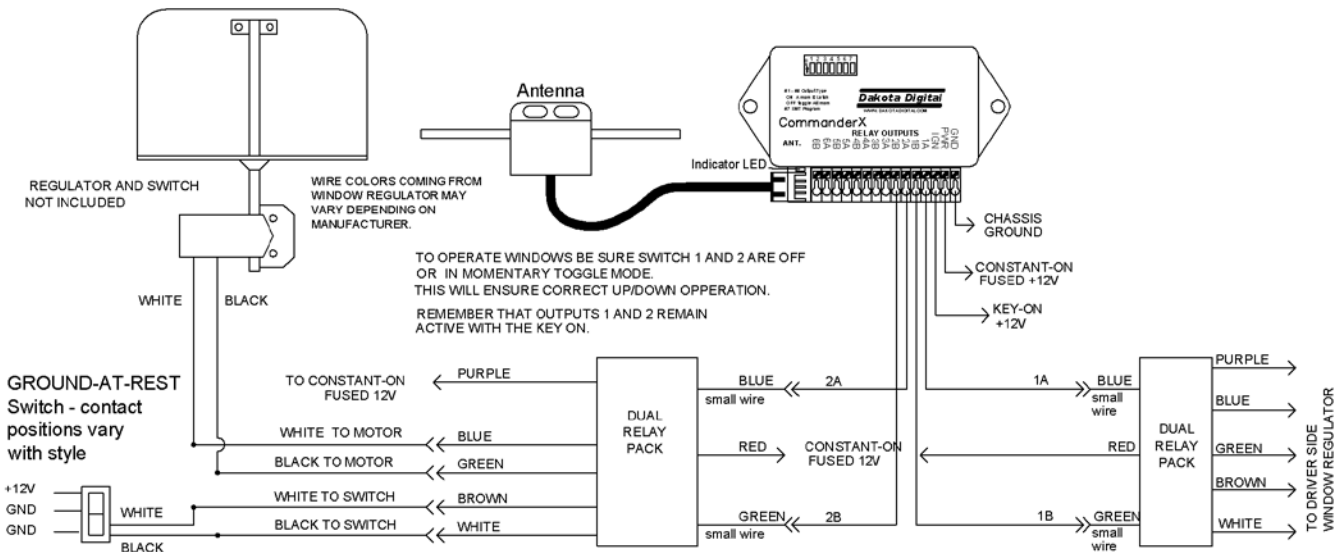

FIGURE 4 Connection to Specialty, Downs, Balls, GM, and other power window regulators using a 5-wire or center-position grounding switch.

This wiring diagram can be used with most power window and switch combinations. The existing switch (or in some cases relays) keep the two wires to the motor grounded when the window is at rest. To move the window up, the “up” wire is switched to 12 volts while the “down” wire remains grounded. To move the window down, the opposite occurs. For both the existing switch and the remote system to be able to move the window, the wires between the switch and the window regulator need to be cut and separated. These wires are then connected to the supplied dual relay pack. One relay in the pack will roll the window up, the other down.

While the remote system itself should not be mounted in the door, the relays can be. Mount them so the wires are going out the bottom. This will prevent water from collecting inside.

The wiring for the passenger side is identical to the driver’s side.

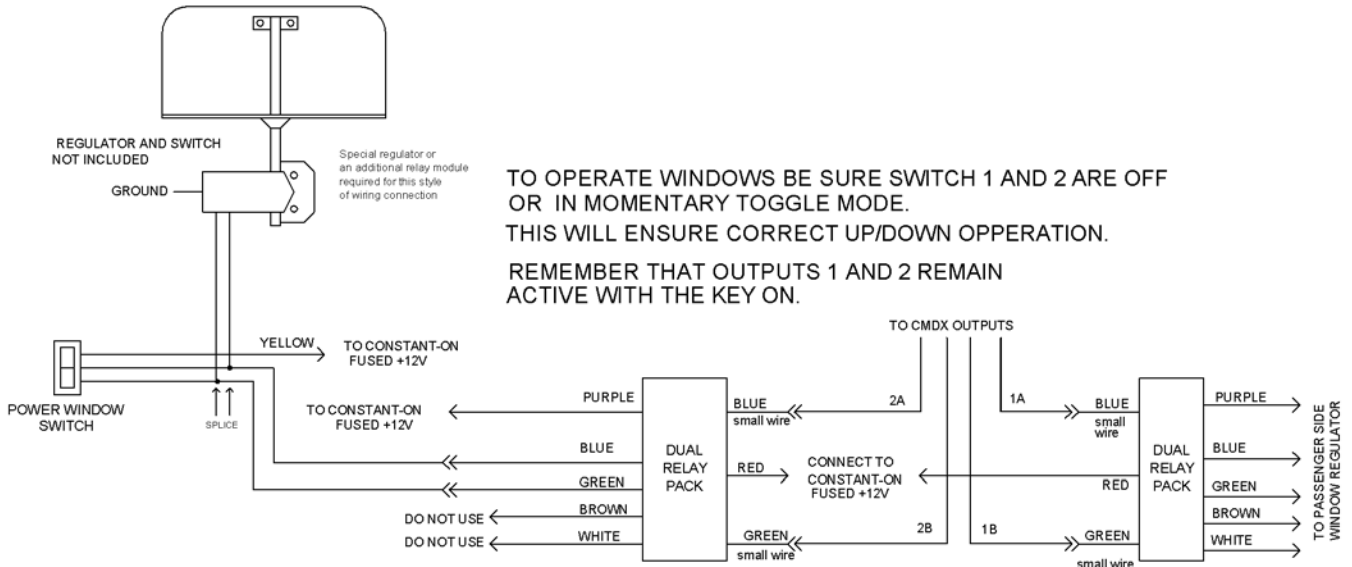

FIGURE 5 Connection to power window regulators with a three wire 12 volt switch.

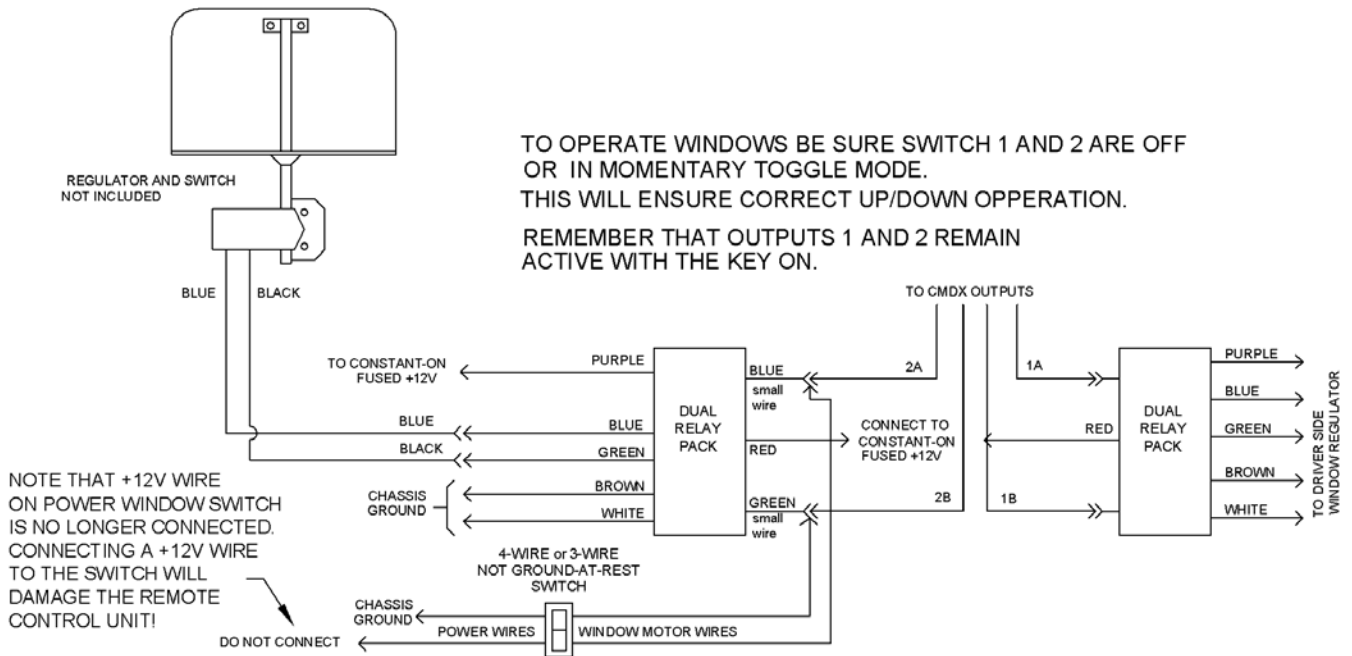

FIGURE 6 Connection to power windows with 4-wire switch (not center position grounding).

POWER TRUNK LIFT WIRING

The trunk lift motor is not included in the base package. These are available from Dakota Digital separately.

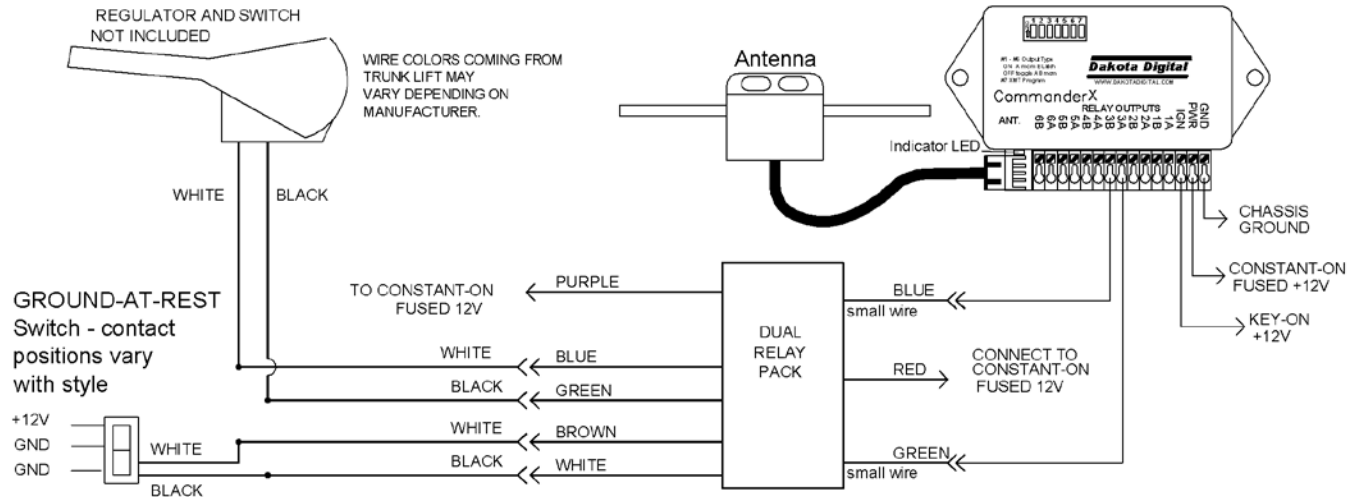

FIGURE 7 Connection to power trunk lift motor.

SINGLE RELAY WIRING FOR AUXILIARY OUTPUTS

There are two single and two dual relay packs included with the CMD-X. There are additional relays available from Dakota Digital (RLY-1 & RLY-2), however any 12 volt, automotive relay will work. This diagram will show how to wire a relay to supply +12V to the desired load. Depending on the desired operation, a latching or momentary output could be used.

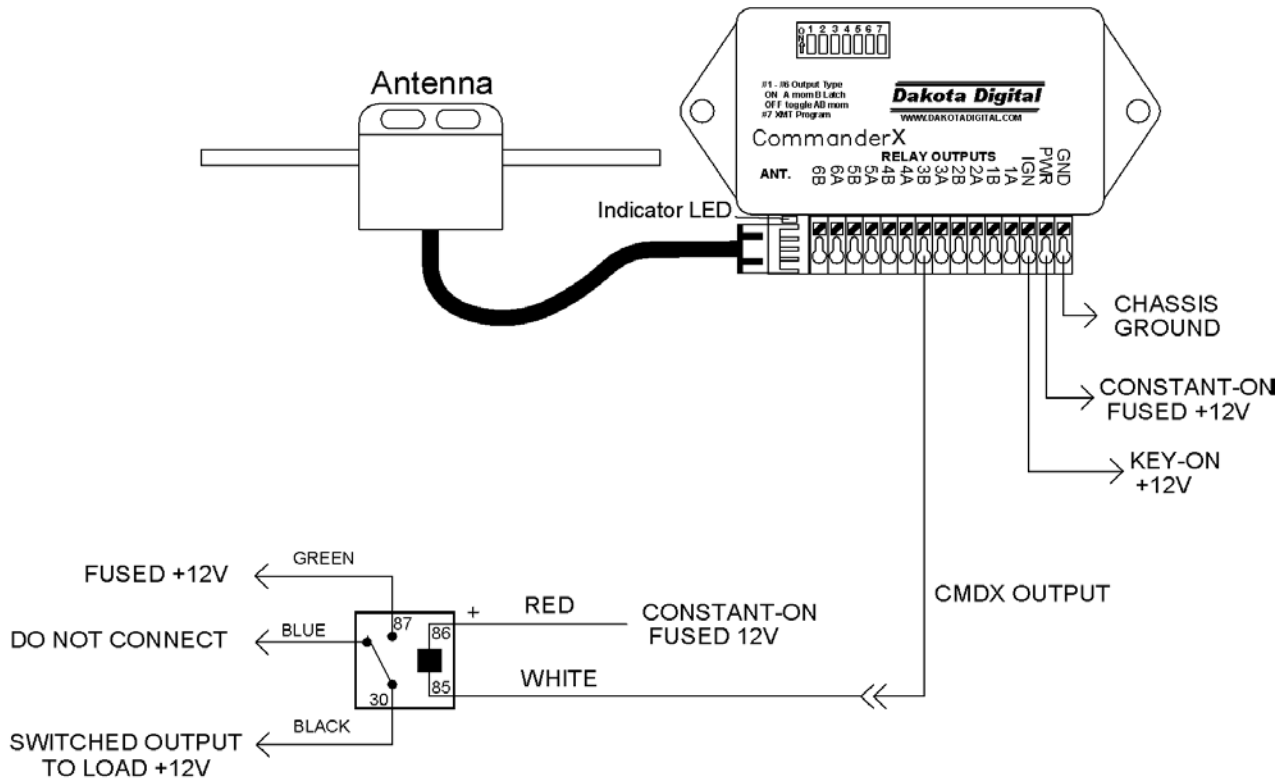

FIGURE 8 Connection to relays for operating accessories with auxiliary outputs.

POWER DOOR LOCK WIRING

The trunk raise/lower channels can also be used for power door locks to add more security to the vehicle. The door lock actuators are not included with the base package. These are sold separately if needed for your application. The CMD-X should be setup for momentary toggling outputs to operate door lock motors, extended power to the lock motor could damage the motor.

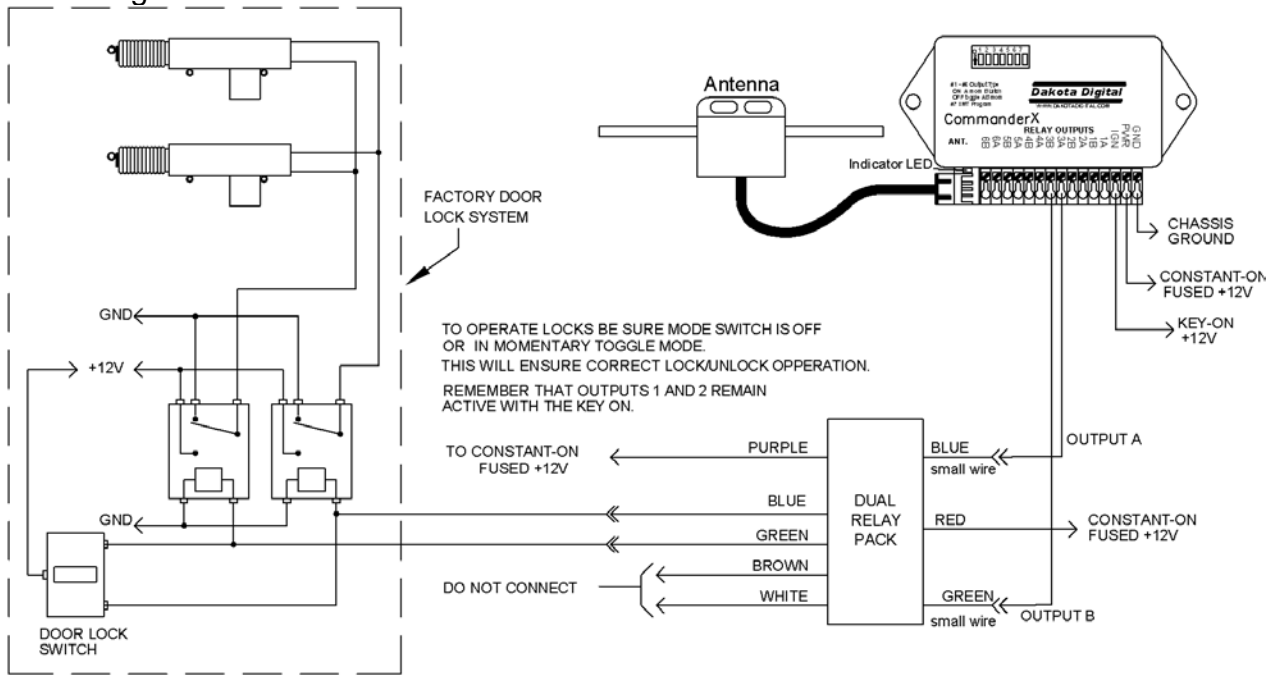

FIGURE 9 Connection to power door locks with 3-wire, +12V switch.

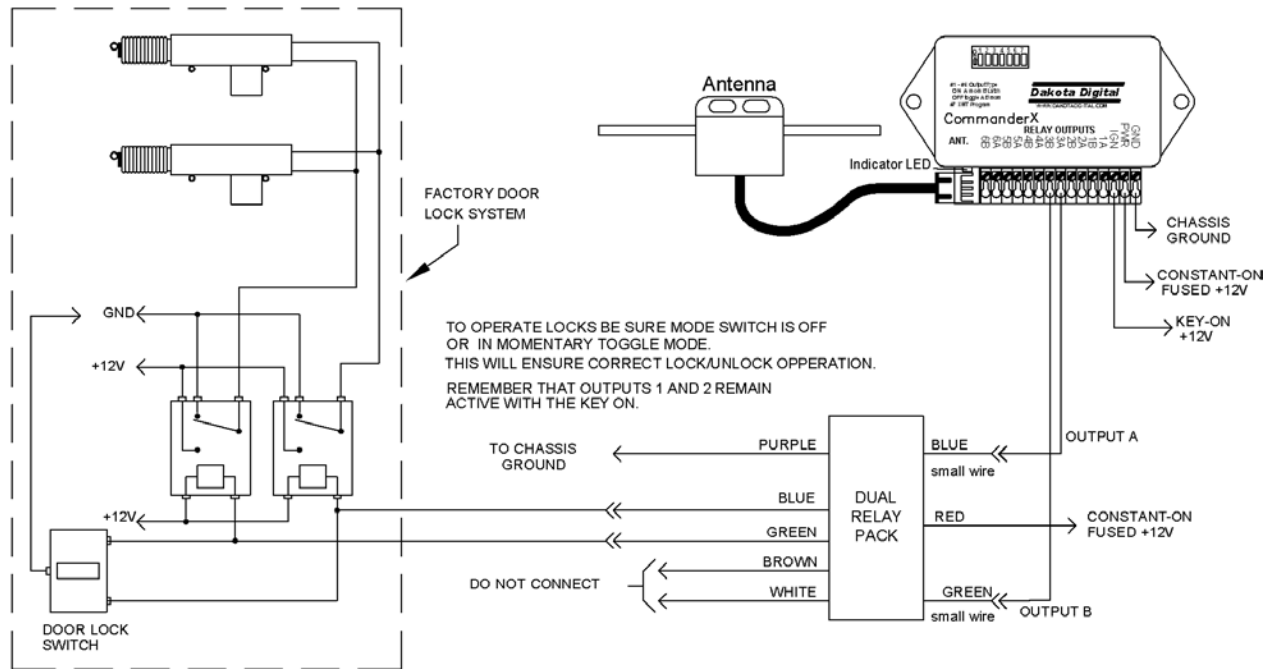

FIGURE 10 Connection to power door locks with 3-wire grounding switch.

POWER DOOR LOCK WIRING

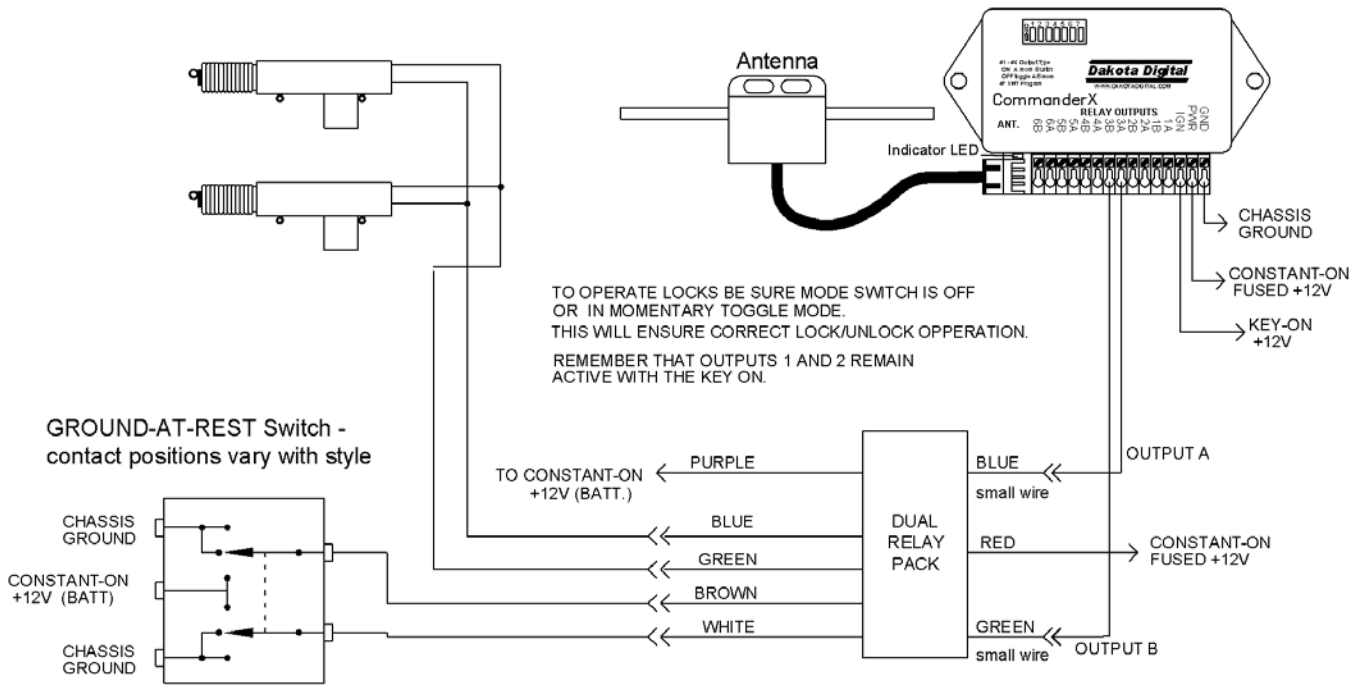
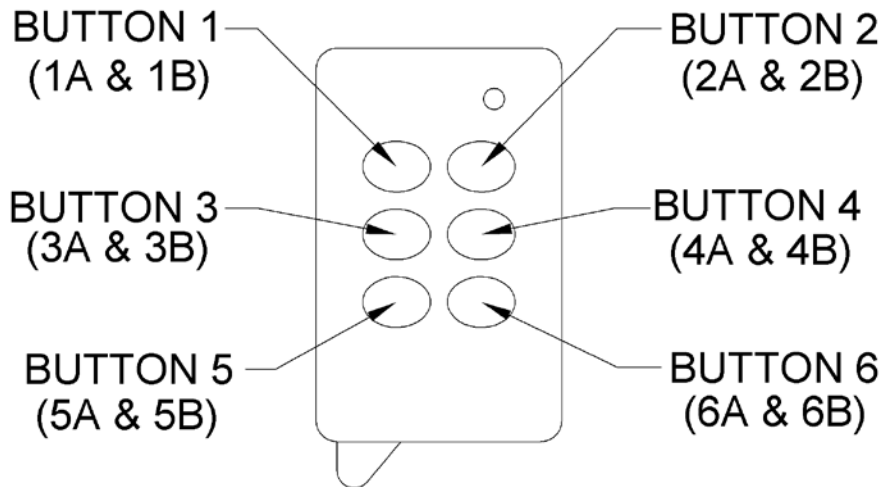

FIGURE 11 Connection to power door locks with a 5-wire switch.

TRANSMITTER BUTTON NUMBERING OUTPUT CONTROLLED



OPERATION FOR MODE 1, DIP switch OFF momentary toggling outputs

The key chain transmitter has six buttons. They are labeled with roman numerals I, II, III, IV, V, and VI. The red light next to the programming switches will flash once briefly each time a button is pressed to verify the command has been received.

Button I controls outputs 1A and 1B, button II controls outputs 2A and 2B, button III outputs 3A and 3B, button IV outputs 4A and 4B, button V outputs 5A and 5B, and button VI outputs 6A and 6B.

There are 7 dip switches on the top of the CMD-X. Switches 1 – 6 are the channel mode control switches. Mode 1 is where the dip switch for a channel is OFF. This places that channel in the momentary toggle mode.

In momentary toggle mode the first time a button is pressed output A is activated, switched to ground, as long as the button is held. The next time the button is pressed output B is activated as long as the button is held.

When the ignition key is on, the only buttons that will work are I and II Buttons III, IV, V, and VI are disabled. Outputs 1A, 1B, 2A, and 2B stay active while the key is on so door latches, or other devices that are not intended to operate when the vehicle is running should not be controlled by these outputs. This safety feature will not allow the doors or trunk to accidentally release while the vehicle is in motion if connected to the appropriate output.

OPERATION FOR MODE 2, DIP switch ON momentary and latching outputs

The key chain transmitter has six buttons. They are labeled with roman numerals I, II, III, IV, V, and VI. The red light next to the programming switches will flash once briefly each time a button is pressed to verify the command has been received.

Button I controls outputs 1A and 1B, button II controls outputs 2A and 2B, button III outputs 3A and 3B, button IV outputs 4A and 4B, button V outputs 5A and 5B, and button VI outputs 6A and 6B.

There are 7 dip switches on the top of the CMD-X. Switches 1 – 6 are the channel mode control switches. Mode 2 is where the dip switch for a channel is ON. This places that channel in the momentary latch mode.

In momentary latch mode output A is activated, switched to ground, as long as the button is held, each time the button is pressed. Output B is the latching output. The first the button is pressed outputs B is latched on, switched to ground. The next time the button is pressed output B is shut off.

When the ignition key is on, the only buttons that will work are I and II Buttons III, IV, V, and VI are disabled. Outputs 1A, 1B, 2A, and 2B stay active while the key is on so door latches, or other devices that are not intended to operate when the vehicle is running should not be controlled by these outputs. This safety feature will not allow the doors or trunk to accidentally release while the vehicle is in motion if connected to the appropriate output.

REMOTE SYSTEM TRANSMITTER LOCK FUNCTION

Due to the long range of this system, some customers may wish to avoid accidentally pressing a button and opening a door when they are out of sight of the vehicle. Pressing buttons V and VI at the same time will lock the receiver from activating any of the outputs. It will remain locked until buttons V and VI are pressed again.

To lock the system:

1. Press and release buttons V and VI at the same time.
2. Press one of the other buttons to verify that the system is locked.

To unlock the system:

1. Press and release buttons V and VI at the same time.
2. Press one of the other buttons to verify that the system is operating normally.

PROGRAMMING SWITCHES

There are seven programming switches located at the top of the CMD-X. They are used to set up the operation of the remote system and to enter the programming mode to program additional transmitters. For output A momentary and output B latching the switch for that channel should be ON. For toggling momentary outputs the switch for the channel should be OFF. Switch 7 is used for programming additional transmitters, covered below in detail.

Switch #1	Select operation mode. (changes output 1A and 1B, momentary or momentary/latch)
Switch #2	Select operation mode. (changes output 2A and 2B, momentary or momentary/latch)
Switch #3	Select operation mode. (changes output 3A and 3B, momentary or momentary/latch)
Switch #4	Select operation mode. (changes output 4A and 4B, momentary or momentary/latch)
Switch #5	Select operation mode. (changes output 5A and 5B, momentary or momentary/latch)
Switch #6	Select operation mode. (changes output 6A and 6B, momentary or momentary/latch)
Switch #7	Enter testing and programming mode.

BATTERY REPLACEMENT

Should the transmitter function become weak or erratic, the battery in the key chain transmitter may be weak. An indication of a weak battery is that the red indicator may have a dim glow to it when any button is pressed. The battery is replaced in the following manner:

1. Use a small, straight screwdriver to pry the two halves apart at the key ring attachment.
2. Carefully separate the two case halves.
3. Remove the battery, noting the (+) and (-) position.
4. Replace the battery with a new 12 volt type GP23A battery which is available at most electronic stores (Radio Shack, battery stores, etc.).
5. Carefully replace the top cover and snap the two pieces together.

INSTRUCTIONS FOR TESTING AND PROGRAMMING TRANSMITTERS

All of the transmitters to be programmed into the system should be available. This sequence will erase any previously programmed transmitters. If a transmitter is lost or stolen, go through the programming sequence with the remaining transmitters and the lost one will be erased. The programming light is located next to terminal strip, next to the ground connection. The IGN terminal must be connected to enter the programming/testing mode as well as the power and ground terminals.

Placing receiver into programming/testing mode.

1. Turn Switch #7 on.
2. Turn on the ignition switch (applying power to the IGN terminal).
3. The red programming light should come on and remain on steady.

Testing the transmitters.

4. Press button V. The programming light should flash as long as the button is held.
5. Press button I. The programming light will flash if the transmitter is currently programmed in. This will also resynchronize the transmitter with the decoder. The number of flashes will indicate the transmitter number.

Programming the transmitters.

6. Turn Switch #7 off. The programming light should go off.
7. Press and release button number III. The programming light should come on.
8. Press and release button number III again. The programming light should flash and then go out. It will flash once for the first transmitter, twice for the second, etc.
9. The transmitter is now stored. If you have more transmitters, take the next transmitter and go back to step 7.
10. When you are finished, turn the ignition key off to exit the programming mode and restart the system.

TROUBLE SHOOTING GUIDE

Symptom	Possible Problem	Solution
System will not operate.	Receiver is not getting power.	Check 12 volt connection. Check ground connection. Check fuses.
	Transmitter is locked.	Press V and VI at the same time.
	Antenna is not plugged in.	Check antenna connection.
Door latch actuators 'jump' or 'chatter'.	System is in test/program mode	Check Switch #7
	Weak or poor 12 volt connection.	Check 12 volt connection to Relays. Move to new terminal point.
Windows change direction in mid-travel.	Over loaded 12 volt power circuit.	Place receiver and windows on separate circuits. Check for loose connections. Increase wire size on power.
	Weak car battery.	Recharge or replace car battery.
	Transmitter signal is being disrupted.	Move antenna away from power wires.
Outputs 1 and 2 work, but all others will not.	Ignition key is on.	Turn off ignition key.
	IGN terminal has 12 volts at all times.	Move IGN wire to a terminal that is powered only when the key is on.
Transmitter has very short range on all functions.	Transmitter battery is weak.	See Battery Replacement.
	Antenna needs repositioning	Move antenna out away from any high current wires.

SERVICE AND REPAIR

DAKOTA DIGITAL offers complete service and repair of its product line. In addition, technical consultation is available to help you work through any questions or problems you may be having installing one of our products. Please read through the Troubleshooting Guide. There, you will find the solution to most problems.

Should you ever need to send the unit back for repairs, please call our technical support line, (605) 332-6513, to request a Return Merchandise Authorization number. Package the product in a good quality box along with plenty of packing material. Ship the product by UPS or insured Parcel Post. Be sure to include the RMA number on the package, and include a complete description of the problem with RMA number, your full name and address (street address preferred), and a telephone number where you can be reached during the day. Any returns for warranty work must include a copy of the dated sales receipt from your place of purchase. Send no money. We will bill you after repair.

Dakota Digital Limited Lifetime Warranty

DAKOTA DIGITAL warrants to the ORIGINAL PURCHASER of this product that should it, under normal use and condition, be proven defective in material or workmanship for the lifetime of the original vehicle it was installed in, such defect(s) will be repaired or replaced at Dakota Digital's option.

This warranty does not cover nor extend to damage to the vehicle's systems, and does not cover removal or reinstallation of the product. This Warranty does not apply to any product or part thereof which in the opinion of the Company has been damaged through alteration, improper installation, mishandling, misuse, neglect, or accident.

This Warranty is in lieu of all other expressed warranties or liabilities. Any implied warranties, including any implied warranty of merchantability, shall be limited to the duration of this written warranty. No person or representative is authorized to assume, for Dakota Digital, any liability other than expressed herein in connection with the sale of this product.

Dakota Digital

4510 W. 61ST St. N., Sioux Falls, SD 57107
Phone: (605) 332-6513 FAX: (605) 339-4106

www.dakotadigital.com
dakotasupport@dakotadigital.com
©Copyright 2005 Dakota Digital Inc.