

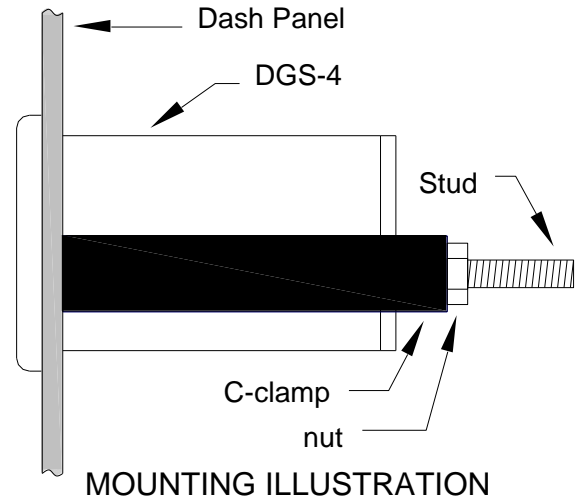

## DGS-4 GEAR SHIFT INDICATOR

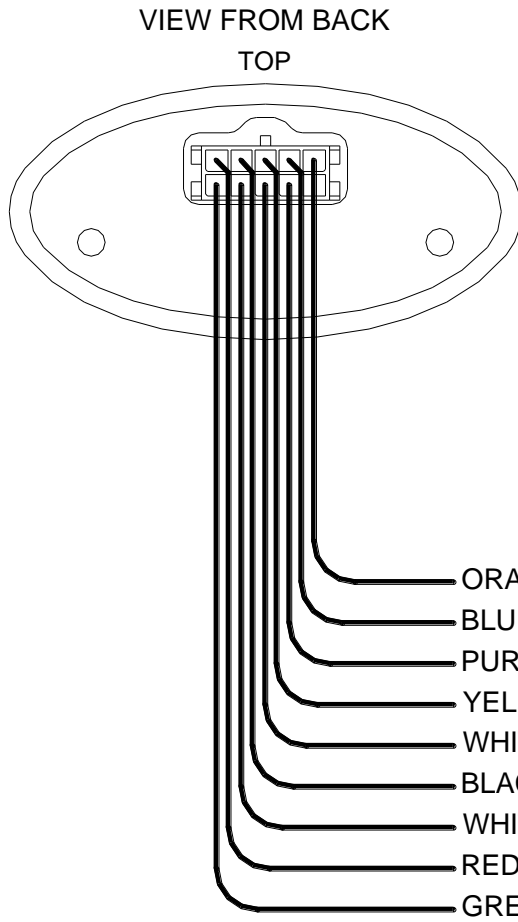

\*NOTE: Both warning indicator inputs must be used.

For ground warning signals, connect WHITE/RED to +12v and WHITE/BLK to signal.

For 12V warning signals, connect WHITE/RED to signal and WHITE/BLK to ground.

### Operation:

The DGS-4 gear indicator unit works with Dakota Digital's gear position sending units (such as the GSS-1000 or GSS-2000). The gear sending unit should be setup for one wire mode (see manual for gear sender). The DGS unit will then display a letter or number indicating the current gear.

The DGS-4 also has 4 additional indicators. These are, left and right turn signal, high beam indicator, and a miscellaneous warning light.

**Setup:**

Wire the DGS-4 according to the wiring diagram on the first page. The left turn, right turn and high beam indicators will light with a +12V signal on the wire. The warning indicator has two possible modes of operation, +12V activated and ground activated. Connect as follows depending on your application.

For a +12v activated warning signal, connect the White/Black wire to ground and connect the White/Red wire to the warning signal wire.

For a ground activated warning signal, connect the White/Red wire to +12v and connect the White/Black wire to the warning signal wire.

The yellow wire should be connected to the one wire signal terminal on the gear sender unit. The gear sender needs to be setup to use one wire mode or the indicator will not work properly.

**Mounting:**

The DGS-4 requires an oval cut out that is about 2-5/16" x 1-1/16". It should be inserted into the opening from the front and the U-clamp will be installed from the back. Tighten the two nuts on the U-clamp so that the display is secure. Figure 1 shows the required cut out for the display. A mounting illustration is included in the wiring diagram on the front page.

Figure 2 shows the full dimensions of the DGS-4 unit to aid in installation.

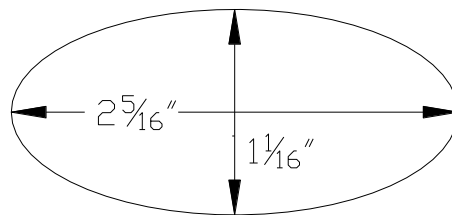

dash cut out

Figure 1

**NOTE!!! Due to differences in printers, the above cutout may not be to scale!  
Always check cutouts for correct measurements before cutting your dash!**

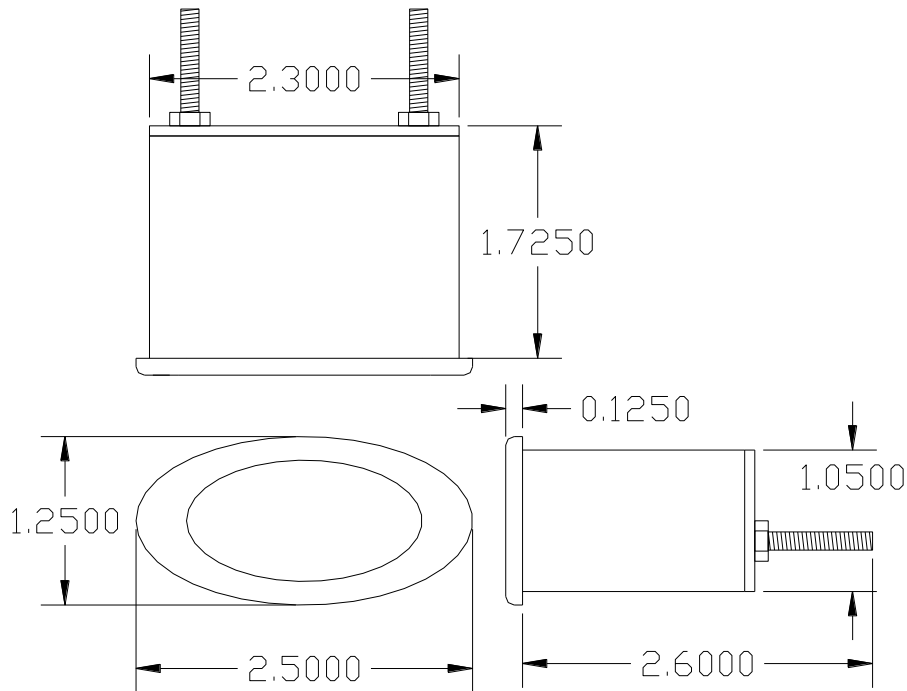

**Figure 2** DGS-4 case dimensions in inches.

### TROUBLESHOOTING

PROBLEM	CAUSE	SOLUTION
Display reads --	Gear data (yellow wire) is shorted to ground or 12v or broken.	Check wire for places it is pinched or broken. Relocate pinched wire and repair breaks or bare spots.
	Gear sender unit not setup for one wire operation.	Set up the gear sender to send a one wire signal instead of wire per gear mode (see gear sender manual.)
Display reads 'E'	Error signal is sent from gear sender.	(See gear sender manual)
Warning indicator doesn't light	One of the wires for warning indicator are not connected.	BOTH wires of the warning indicator must be used for it to light. For high activated warning, Wht/Red goes to warning signal and Wht/Blk MUST go to ground. For ground activated signal, Wht/Blk goes to signal and Wht/Red MUST go to +12v

## **SERVICE AND REPAIR**

DAKOTA DIGITAL offers complete service and repair of its product line. In addition, technical consultation is available to help you work through any questions or problems you may be having installing one of our products. Please read through the Troubleshooting Guide. There, you will find the solution to most problems.

**Should you ever need to send the unit back for repairs, please call our technical support line, (605) 332-6513, to request a Return Merchandise Authorization number.** Package the product in a good quality box along with plenty of packing material. Ship the product by UPS or insured Parcel Post. Be sure to include the RMA number on the package, and include a complete description of the problem with RMA number, your full name and address (street address preferred), and a telephone number where you can be reached during the day. Any returns for warranty work must include a copy of the dated sales receipt from your place of purchase. Send no money. We will bill you after repair.

### **Dakota Digital 24 Month Warranty**

DAKOTA DIGITAL warrants to the ORIGINAL PURCHASER of this product that should it, under normal use and condition, be proven defective in material or workmanship within 24 MONTHS FROM THE DATE OF PURCHASE, such defect(s) will be repaired or replaced at Dakota Digital's option.

This warranty does not cover nor extend to damage to the vehicle's systems, and does not cover removal or reinstallation of the product. This Warranty does not apply to any product or part thereof which in the opinion of the Company has been damaged through alteration, improper installation, mishandling, misuse, neglect, or accident.

This Warranty is in lieu of all other expressed warranties or liabilities. Any implied warranties, including any implied warranty of merchantability, shall be limited to the duration of this written warranty. Any action for breach of any warranty hereunder, including any implied warranty of merchantability, must be brought within a period of 24 months from date of original purchase. No person or representative is authorized to assume, for Dakota Digital, any liability other than expressed herein in connection with the sale of this product.

**⚠ WARNING:** This product can expose you to chemicals including lead, which is known to the State of California to cause cancer and birth defects or other reproductive harm. For more information go to [www.P65Warnings.ca.gov](http://www.P65Warnings.ca.gov)



4510 W. 61st St. North  
Sioux Falls, SD 57107  
www.dakotadigital.com  
dakotasupport@dakotadigital.com

Phone (605) 332-6513  
Fax (605) 339-4106

Copyright 2011 - Dakota Digital, Inc.