

Dakota Digital

DGS-2 or DGS-2B VFD ALPHANUMERIC GEAR SHIFT INDICATOR

INTRODUCTION

Thank you for purchasing the Dakota Digital, Inc. DGS-2 VFD Alphanumeric Gear Shift Indicator. This, along with many other products that Dakota Digital, Inc. has to offer, represents the latest in electronics technology for the street rod, classic car and truck, and any custom vehicle.

This indicator is designed to tell you what gear your automatic transmission is in when used with the appropriate sending unit. It is designed to work with Dakota Digital's GSS-1000 Universal Gear Shift Sender, Ron Francis Wire Works gear shift sender, or any other sender that provides 12 volt signals for the gears. It uses an 8 character display to spell out the full name of the gear. The vacuum florescent display matches Dakota Digital's popular VFD gauge systems and is available in the same colors. The indicator also features a night dimming feature which allows it to dim to a preset brightness when your headlights are turned on.

MOUNTING DGS-2 (without bezel)

The indicator and enclosed lens mount behind an opening in your dash which should be at least 2" x 5/8" and can be up to 2 7/8" x 1 3/4" with the standard lens. A flange with mounting hole is provided on the right and left sides of the indicator. These can be used to mount the lens and indicator by tacking a pair of #8 or #10 studs to the back of your dash. An alternative method of mounting is to use silicone RTV to mount the lens and indicator to your dash. You should allow at least 2" of depth behind your dash for the indicator and wiring. The grommet where the wires exit the indicator is on the bottom side of the indicator. Make sure to not install the unit upside down.

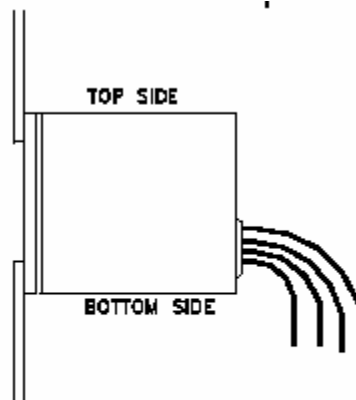

MOUNTING DGS-2B (with aluminum bezel)

The indicator is designed to be mounted into a 1 5/8" tall x 2 7/8" opening. The indicator will be inserted into the opening from the front and the U-clamp will be secured from the back on the two studs to hold the unit in place. The grommet where the wires exit the indicator is on the bottom side of the indicator. Make sure to not install the unit upside down. The diagram below illustrates the mounting configuration.

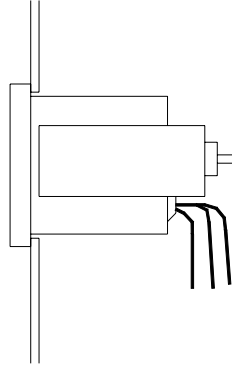

WIRING

There are 10 wires on the indicator; power and ground wires, seven wires for the gear inputs, and a night dimming wire. The color code is as follows:

RED	-	12 volt accessory power.
BLACK	-	Ground.
WHITE w/BLUE-		Dimming input (connect to tail light circuit).
GREEN	-	PARK input
GRAY	-	REVERSE input
PURPLE	-	NEUTRAL input
YELLOW	-	OVRDRIVE input
ORANGE	-	DRIVE input
BLUE	-	SECOND input
BROWN	-	FIRST input

Each input is activated by sending 12 volts to it. When none of the gear inputs have a 12 volt signal connected, the indicator will keep flashing 'DAKOTA' 'DIGITAL' on the display. It will also flash this once each time it is powered up.

WIRING DIAGRAMS

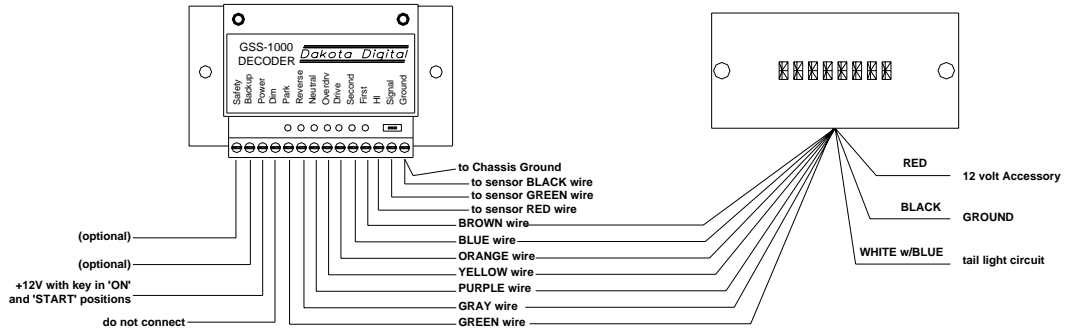

Wiring DGS-2 indicator to GSS-1000 sender

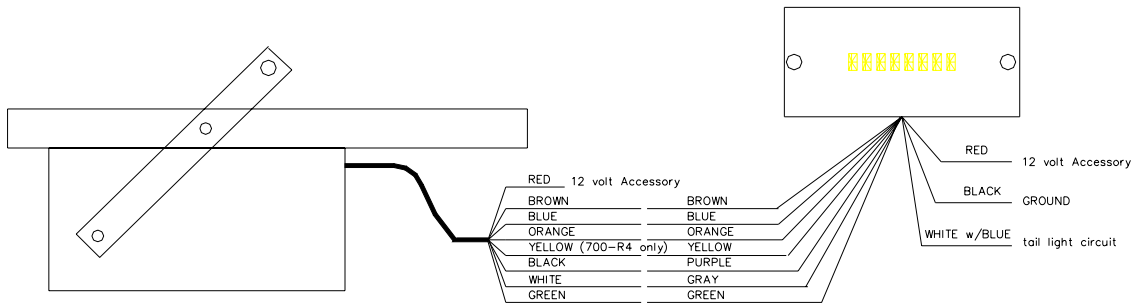

Wiring DGS-2 indicator to Wire Works sender

**DGS-2 VFD ALPHANUMERIC GEAR SHIFT INDICATOR
LIMITED LIFETIME WARRANTY**

DAKOTA DIGITAL, INC. (the Company) warrants to the ORIGINAL PURCHASER of this product that the system, under normal use and condition, be proven defective in material or workmanship DURING THE LIFETIME OF THE CAR IN WHICH IT WAS ORIGINALLY INSTALLED, such defect(s) will be repaired or replaced (at the Company's option) without charge for parts or labor directly related to repairs of the defect(s).

To obtain repair or replacement within the terms of this Warranty, the product is to be delivered with proof of warranty coverage (e.g., dated bill of sale), specification of defect(s), transportation prepaid, to the factory. This Warranty is valid for the original purchaser only and may not be transferred.

This Warranty does not cover nor extend to damage to vehicle electrical system. This Warranty does not apply to any product or part thereof which in the opinion of the Company has been damaged through alteration, improper installation, mishandling, misuse, neglect, or accident.

This Warranty is in lieu of all other express warranties or liabilities. ANY IMPLIED WARRANTIES, INCLUDING ANY IMPLIED WARRANTY OF MERCHANTABILITY, SHALL BE LIMITED TO THE DURATION OF THIS WRITTEN WARRANTY. ANY ACTION FOR BREACH OF ANY WARRANTY HEREUNDER INCLUDING ANY IMPLIED WARRANTY OF MERCHANTABILITY MUST BE BROUGHT WITHIN A PERIOD OF 30 MONTHS FROM DATE OF ORIGINAL PURCHASE. IN NO CASE SHALL THE COMPANY BE LIABLE FOR ANY CONSEQUENTIAL OR INCIDENTAL DAMAGES FOR BREACH OF THIS OR ANY OTHER WARRANTY, EXPRESSED OR IMPLIED, WHATSOEVER. No person or representative is authorized to assume for the Company any liability other than expressed herein in connection with the sale of this product.

The Company does not warrant that this product cannot be compromised or circumvented. THE EXTENT OF THE COMPANY'S LIABILITY UNDER THIS WARRANTY IS LIMITED TO THE REPAIR OR REPLACEMENT PROVIDED ABOVE AND, IN NO EVENT, SHALL THE COMPANY'S LIABILITY EXCEED THE PURCHASE PRICE PAID BY THE PURCHASER FOR THE PRODUCT.

Some states do not allow limitations on how long an implied warranty lasts or the exclusion or limitation if incidental or consequential damage so the above limitations or exclusion may not apply to you. This Warranty gives you specific legal rights and you may also have other rights which vary from state to state.

DAKOTA DIGITAL, INC. * 4510 W. 61ST ST. N. * Sioux Falls, SD 57107 * (605) 332-6513

Dakota Digital

Universal Gear Shift Sender GSS-1000

The easiest system to install and use on the market.

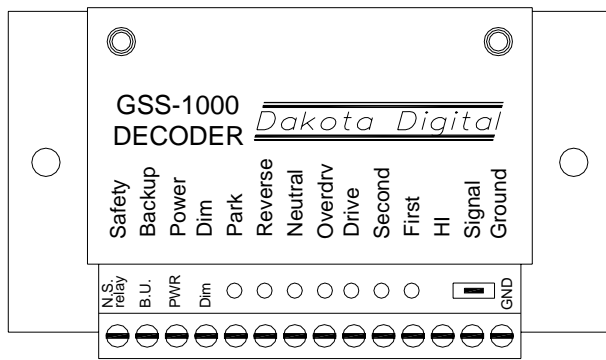

gear shift decoder.

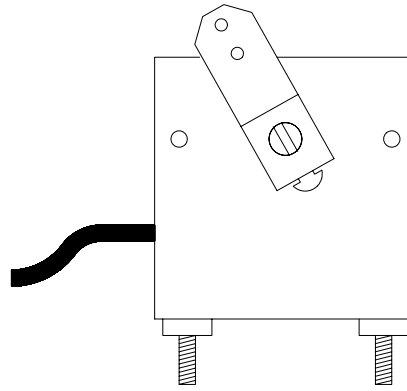

gear shift sensor.

The Dakota Digital universal gear shift sender consists of 3 main components, these are the sensor, decoder, and mounting brackets. The sender mounts to the transmission and converts the transmission linkage arm position into an electrical signal. The decoder converts the electric signal from the sender into the individual outputs for each gear and provides the neutral safety and backup features. This unit can also support single-wire indicators from Dakota Digital, Inc. These style indicators have only one wire that sends the digital gear position information to the display. The mounting brackets attach the sensor to the transmission housing and linkage arm.

The only parts of the gear shift sender that are different for the different transmissions are the mounting brackets. The GM 350, 400, and 700-R4 use the same linkage connector and mounting plate, but different holes in the mounting plate. The Ford C-6 and C-4 each have different mounting plates and linkage connectors.

For other transmissions, a universal mounting plate is provided. This plate has several mounting holes for the sensor, but no holes for mounting the plate to the transmission. To use this plate, first determine the best mounting location on your transmission and then mark and drill holes into the universal plate to secure it. In most instances the entire length of the plate will not be needed and it can be cut down using a hack saw or metal shears.

The arm which is mounted on the sender allows for a 1 3/4" throw with the outside hole and 1 5/16" throw with the inside hole. The longer arm which is sent in the kit allows for throws from 3 1/2" with the outside hole to 2 3/16" with the inside hole. The sensor does not have to use all of the travel available to work. It does not matter what part of the travel the sensor uses.

PARTS LIST

description	quantity
gear shift decoder	1
relay for neutral safety	1
gear shift sender with 10' cable	1
long gear shift sender arm	1
spacer (7/16" hex nut)	2
5/16" x 1" bolt	2
5 1/4" rod	1
4 1/4" rod	1
3 1/4" rod	1
1/8" retainer clips for rods	6
GM mounting plate	1
GM linkage connector	1
C-4 mounting plate	1
C-4 linkage connector	1
C-6 mounting plate	1
C-6 linkage connector	1
universal mounting plate	1

WIRING

The terminals on the decoder are connected as follows:

SAFETY	Connect to neutral safety relay.
BACKUP	positive side of backup lights
POWER	Ignition terminal from fuse panel
DIM	Park light or tail light circuit (for LED indicators only) *Connect to power for single-wire indicators
PARK	to park indicator
REVERSE	to reverse indicator
NEUTRAL	to neutral indicator
OVERDRV	to overdrive indicator
DRIVE	to drive indicator
SECOND	to second indicator
FIRST	to first indicator *data out for single-wire indicators
HI	red wire from gear sensor
SIGNAL	green wire from gear sensor
GND	chassis ground and black wire from gear sensor

The neutral safety and backup light features do not have to be connected for gear sender to work. These are optional features provided for vehicles which do not already have these provisions.

CONNECTING SENSOR TO DECODER

The sensor has a 10 foot gray cable attached to it. This cable contains 3 wires which connect to the decoder. Connect the RED wire to the terminal marked HI. Connect the GREEN wire to the terminal marked SIGNAL. Connect the BLACK wire to the terminal marked GND. The GND terminal will also have another wire to chassis ground.

CONNECTING THE NEUTRAL SAFETY RELAY

If your vehicle already has a neutral safety switch in the wiring harness to prevent the vehicle from starting while it is in gear, then you do not need to connect this neutral safety switch.

Otherwise, cut the wire that goes from your starter switch to the starter solenoid. Connect one end of the wire to the GREEN wire from the relay and connect the other end BLACK wire from the relay. For wiring harnesses which provide wires for the neutral safety, connect one side to the GREEN wire and the other side to the BLACK wire.

The WHITE wire from the relay connects to the SAFETY terminal on the decoder. The RED wire connects to the power wire for the decoder. For the neutral safety switch to operate properly, the POWER terminal must have power when the key is in both the run and start positions.



CONNE

CONNECTING PARK-NEUTRAL SIGNAL TO AN ECM

If your vehicle is fuel injected and the ECM requires a signal when the transmission is in either park or neutral, the neutral safety terminal can be used. The SAFETY terminal provides a ground when the transmission is in park or neutral. This can be connected to the ECM in order to pass vehicle inspection.

The SAFETY terminal can be used for both a neutral safety and ECM signal at the same time.

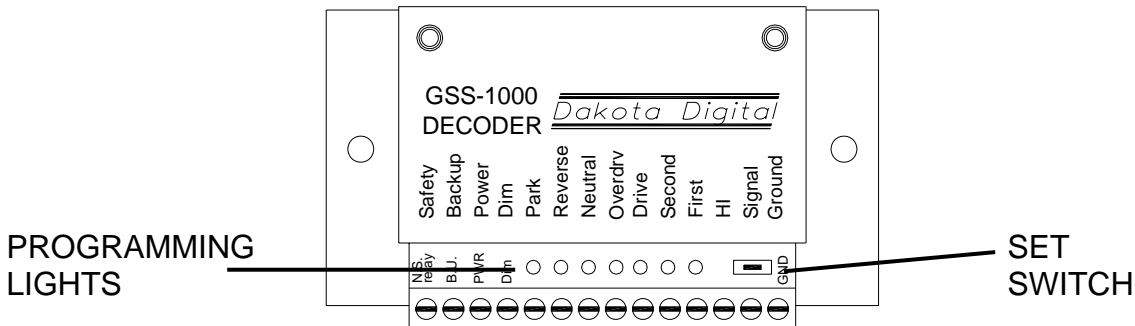

PROGRAMMING THE GEARS

Programming is done using the set push-button switch located by the sensor connection terminals and watching the programming lights located by the gear outputs. The PARK light is directly behind the PARK terminal, REVERSE light is directly behind the REVERSE terminal, etc. The switch can be pressed using a pen, pencil, screwdriver, or other blunt object.

1. Place the transmission in PARK and make sure the key is off.
2. Press and hold the set switch while turning the key on.
3. The PARK light should be flashing. Release the set switch.
4. Press the set switch. The PARK light should remain on steady.
5. Release the set switch. The REVERSE light should begin flashing and the PARK light will go out.
6. Shift the transmission to REVERSE.
7. Press the set switch. The REVERSE light should remain on steady.
(If the REVERSE light will not quit flashing, then the sensor is not turning.)
8. Release the set switch. The NEUTRAL light should begin flashing and the REVERSE light will go out.
9. Shift the transmission to NEUTRAL.
10. Press the set switch. The NEUTRAL light should remain on steady.
(If the light will not quit flashing, then the sensor is not turning.)
11. Release the set switch. The OVERDRIVE light should begin flashing and the NEUTRAL light will go out.
12. Shift the transmission to OVERDRIVE. (If you do not have overdrive, then shift to DRIVE.)
13. Press the set switch. The OVERDRIVE light should remain on steady.
(If the light will not quit flashing, then the sensor is not turning.)
14. Release the set switch. The DRIVE light should begin flashing and the OVERDRIVE light will go out.
15. Shift the transmission to DRIVE. (If it is already in drive, then do not move it.)
16. Press the set switch. The DRIVE light should remain on steady.
17. Release the set switch. The SECOND light should begin flashing and the DRIVE light will go out.
18. Shift the transmission to SECOND. (If you do not have second, then shift to FIRST.)
19. Press the set switch. The SECOND light should remain on steady.
(If the light will not quit flashing, then the sensor is not turning.)
20. Release the set switch. The FIRST light should begin flashing and the SECOND light will go out.
21. Shift the transmission to FIRST. (If it is already in first, then do not move it.)
22. Press the set switch. The FIRST light should remain on steady.
23. Release the set switch. The FIRST light will go out and then come back on steady.
24. Shift the transmission through each of the gears to verify that the programming lights match correctly.

CONNECTING TO THE GEAR SHIFT DISPLAY

Gear shift displays are not included with the GSS-1000, but it will interface with all of the standard display systems available. Each gear output will provide 12 volts at up to 0.3 amperes. This is enough current capacity for any LED indicator or low power incandescent bulbs. When individual lights are used for each gear, connect the negative wire to ground and the positive wire to the appropriate gear output terminal on the decoder. When using Dakota Digital's Digital Gear Shift Indicator connect the wires to the decoder according to the instructions provided with the indicator. The GSS-1000 will also work with any Dakota Digital vacuum florescent display system. Connect wire jumpers between the decoder and the display system control box.

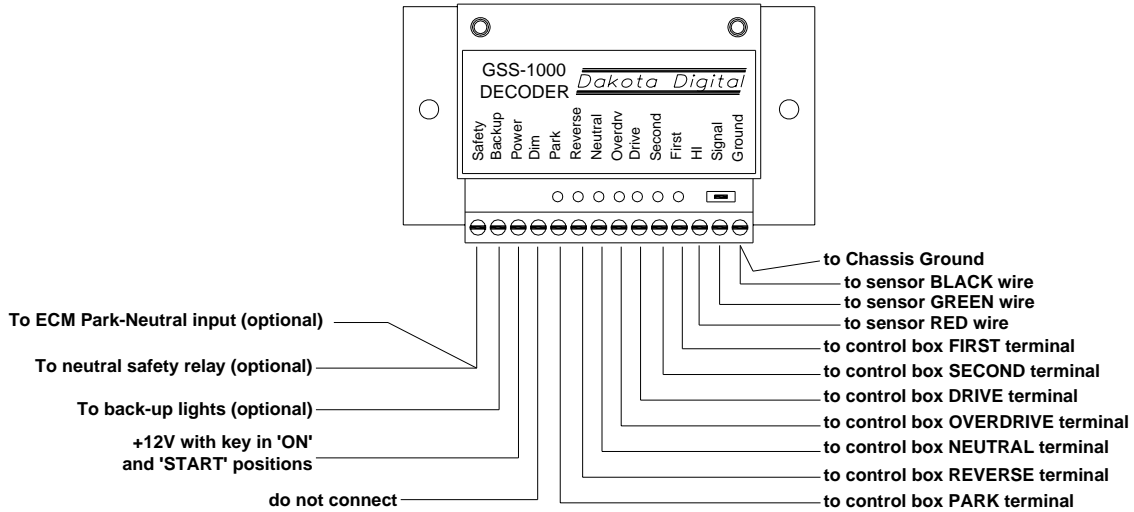

Wiring GSS-1000 to Dakota Digital VFD instrumentation system (STR systems)

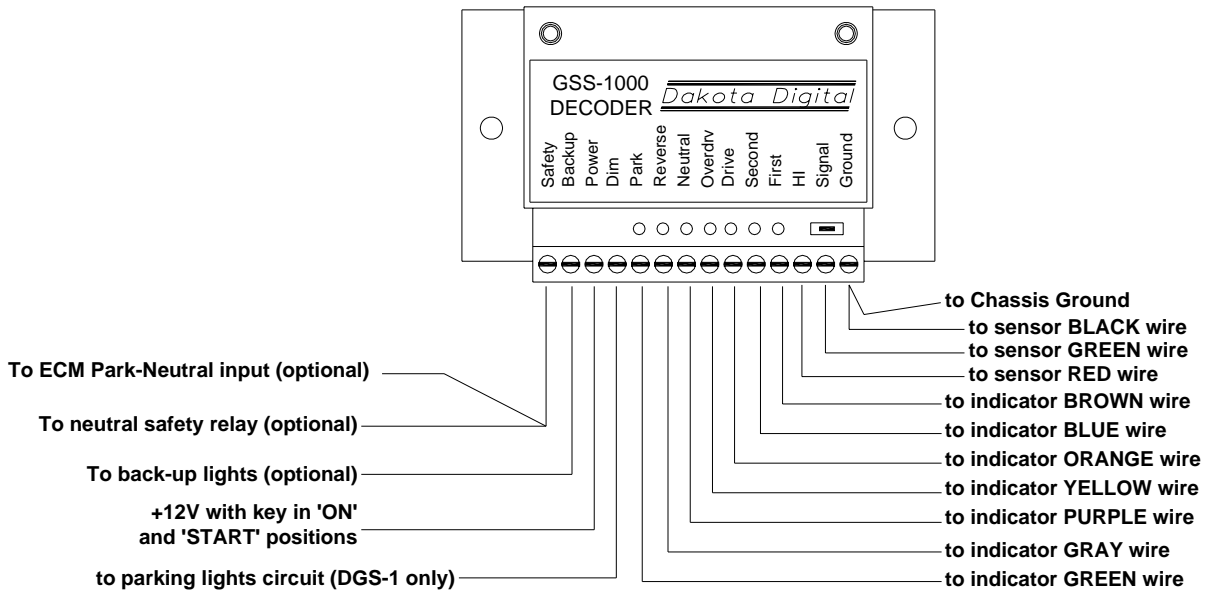

Wiring GSS-1000 to Dakota Digital individual gear shift indicator (DGS-1 or DGS-2)

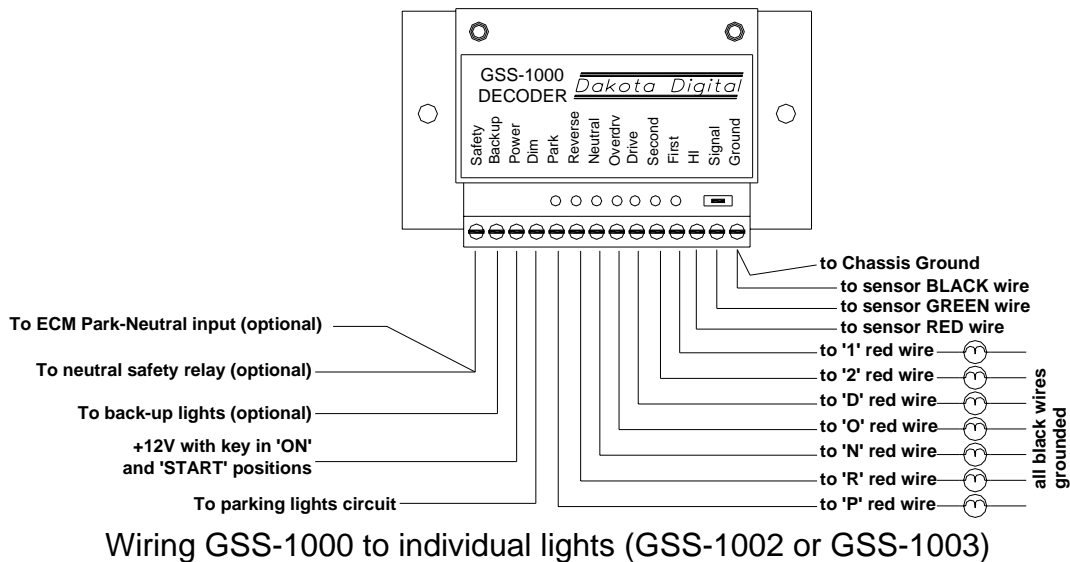

CONNECTING TO SINGLE-WIRE DISPLAYS

The ODYR-01-1 and ODYR-02-1 gauges have a brown wire in their harness for connecting to the GSS-1000. Single-wire displays use only one wire to read the gear position from the GSS-1000 decoder instead of using six or seven wires (one for each gear position). To set the decoder up for single-wire mode the DIM terminal must have power during the gear programming. When the decoder is operating in this mode the FIRST programming light will always remain on dimly. The programming light for the gear that it is in will also flash showing the current gear position (when the gear selector is in park the PARK light will flash and the FIRST light will be on dimly.) The PARK, REVERSE, NEUTRAL, OVRDRIVE, DRIVE, and SECOND terminals should not be connected to anything. The FIRST terminal will go to the single-wire gear input on the display.

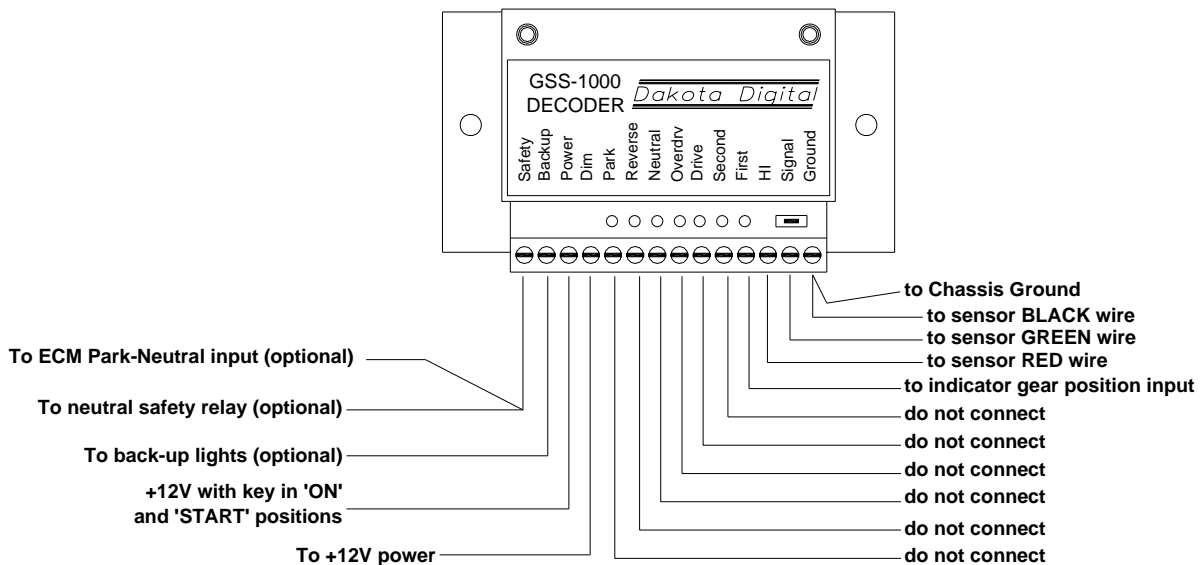

CONNECTING BACKUP LIGHTS TO THE GSS-1000

If your vehicle already has a backup light switch, then you do not need to connect anything to the BACKUP terminal. If you do not have a backup switch and will be using backup lights on your vehicle, then connect the hot side of the backup lights to the terminal marked BACKUP. This circuit is designed to supply up to 15 amps.

MOUNTING SENSOR TO TRANSMISSION.

The diagrams on the following pages show the mounting hardware used and mounting location for the most common transmissions. For most applications, the sensor mounts to the side of the transmission using a couple of the transmission pan bolts. A metal plate will attach to the transmission linkage so that it rotates as the transmission is shifted. A rod with a couple of bends in it connects the sensor arm to the plate on the transmission linkage. This allows the sensor arm to move as the transmission is shifted through the gears. Each gear will correspond to a different position for the sensor arm. It does not matter exactly where the sensor arm is when it is in park, first or any other gear. Once the Decoder has been programmed it will remember the positions. The Decoder converts these positions into separate a 12 volt output for each gear.

If a Kugel adjustable shifter is being used, you will need a Kugel nut to attach the sensor to the shift linkage. The Kugel nut is available from Dakota Digital, Inc.

As the transmission is shifted through all of the gears, the sensor arm should not hit either of its stops, or get 'bound' or 'hung up'. When properly adjusted, the sensor arm will move through about 1/2 or more of its full travel. If the sensor arm moves through less than 1/3 of its travel, it may be difficult for the decoder to distinguish between gears. It does not matter which direction the sensor arm turns going from Park to Low. Once the Decoder has been programmed it will read all of the gears correctly.

If the typical mounting location for the sensor will not work, the sensor can be mounted anywhere that will allow the sensor arm to move as the gear shift selector moves. The sensor arm can attach either at the transmission linkage or at the gear selector knob or anywhere in between.

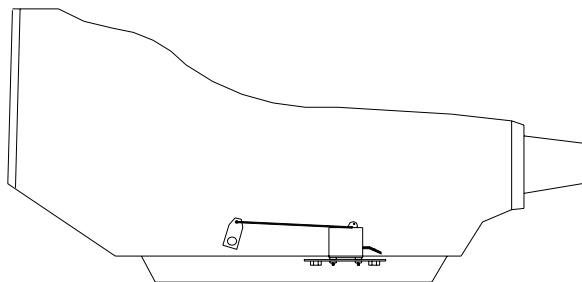

Approximate sender mounting location on transmission.

Mounting to a GM 350, 400, or 700-R4 transmission.

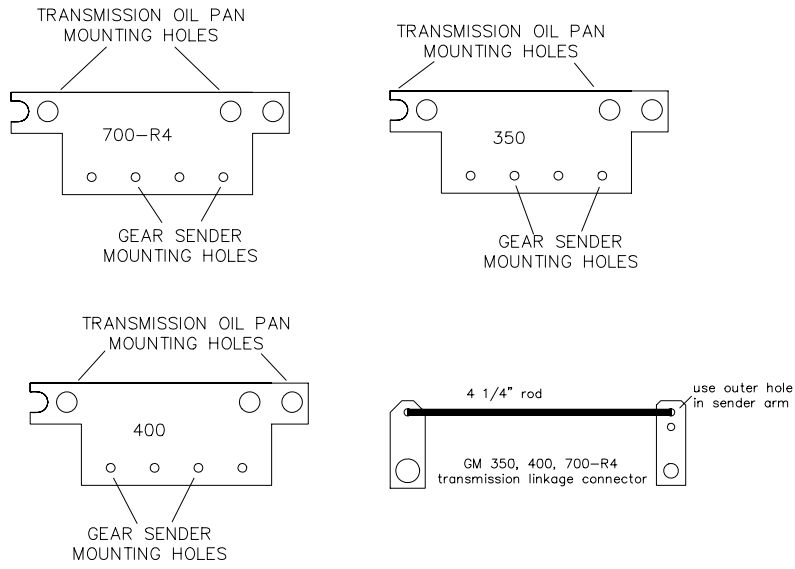

top left side view of GM 700-R4 transmission

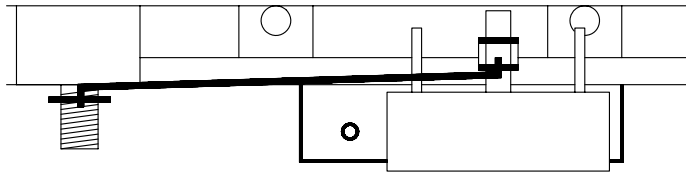

top left side view of GM 400 transmission

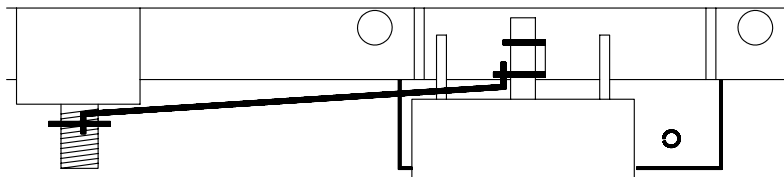

top left side view of GM 350 transmission

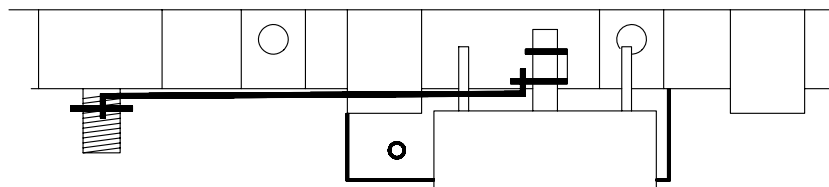

Mounting to a Ford C-6 transmission

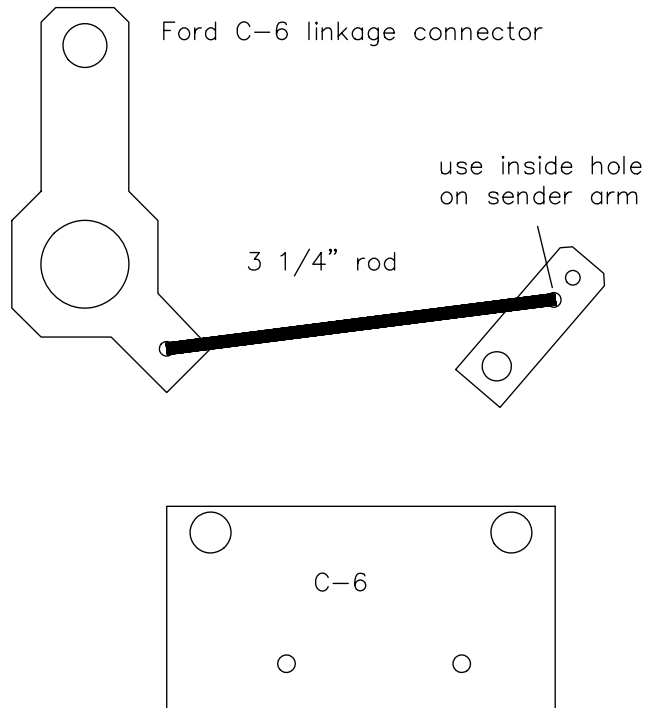
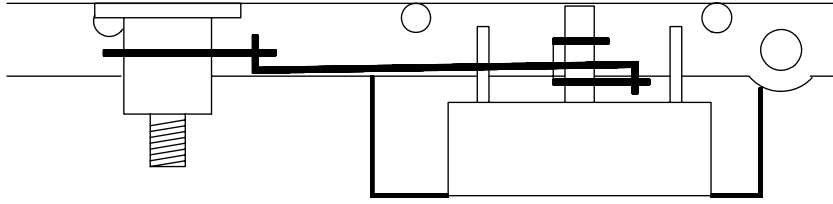

Depending on the shifter you are using, you may use the linkage connector provided. The bottom hole is for the sensor rod, the center hole is a pivot point for the connector, and the upper hole connects to the linkage rod. A nylon cable tie can be passed around the linkage connector and transmission shift arm to keep the linkage connector secured tightly. If this does not fit your shifter, then you will need to drill an 1/8" hole into your shift linkage arm to attach the rod to.

The GM, Ford C-6, and universal mounting plates secure to the transmission oil pan using the supplied 1" bolt, spacer, and washer provided in the kit. On the universal mounting plate, the holes will have to be drilled to line up with the pan bolts being used on the transmission.

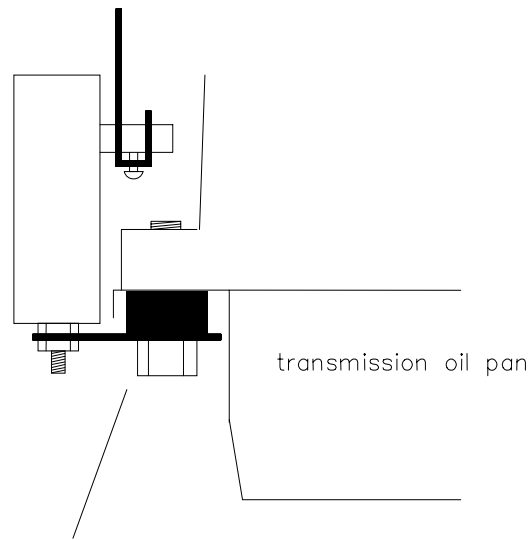

use 3/8" x 1" bolt and 3/8" spacer
as shown above to secure mounting
plate to transmission

Use 5/16" x 1" bolt and spacer (7/16" nut) as shown above to
secure the mounting plate to the transmission



Universal mounting plate.

This can be used with transmissions for which a specific mounting plate is not provided.

Mounting to a Ford C-4 transmission

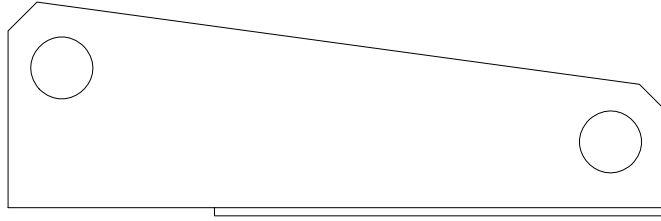

This mounting plate connects to the lower two bolts of the four bolt plate located on the left side of the transmission just behind the shift linkage arm.

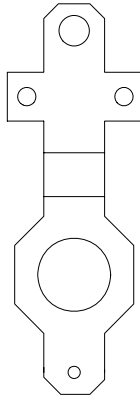

Ford C-4 linkage connector.

Depending on the shifter you are using, you may use the linkage connector provided. The bottom hole is for the sensor rod, the center hole is a pivot point for the connector, and the upper hole connects to the linkage rod. A nylon cable tie can be passed through the two side holes and around the linkage connector to keep the linkage connector secured tightly. If this does not fit your shifter, then you will need to drill an 1/8" hole into your shift linkage arm to attach the rod to.

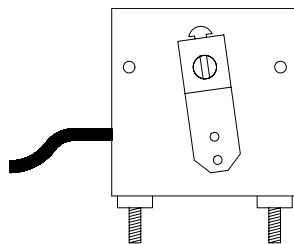

For the C-4 transmission the arm on the gear shift sender will need to be flipped around so that it rotates on the bottom half. Make sure that the slot in the shaft is in line with the sender arm as shown in the diagram.

TROUBLE SHOOTING GUIDE

Problem	Cause	Solution
None of the lights will come on.	Power wire not connected. Ground wire not connected.	Make sure +12 volt wire is connected. Make sure the ground wire is connected to a good ground.
Always shows the same gear or will not set properly.	Sensor wire not connected. Sensor arm not connected. Sensor linkage connector is stuck or bound up. Decoder has not been set.	Make sure all three wires from the sensor are connected. Make sure the sensor arm moves as the gear selector is moved. Make sure the linkage connector and sensor arm move freely as the trans. is shifted through the gears See Programming The Gears section in manual.
Reverse and Overdrive lights are on at the same time.	Sensor ground wire open. Sensor is moving out of its operating range.	Check sensor wire connections. Loosen sensor arm set screw. Rotate sensor shaft ¼ turn. Retighten set screw.
Overdrive and Second lights are on at the same time.	Sensor RED wire open. Sensor signal wire is shorted to ground. Sensor is moving out of its Operating range.	Check sensor wire connections. Check sensor cable. Loosen sensor arm set screw. Rotate sensor shaft ¼ turn. Retighten set screw.
Overdrive, Neutral, and Drive Lights are flashing.	Decoder settings are incorrect or have been corrupted.	Reprogram the decoder. See the Programming The Gears section.
The First light is on dimly and the light for the gear position is flashing.	The decoder is in single-wire mode.	To set the decoder for standard outputs, reprogram the decoder making sure the DIM terminal does not have power.
The neutral safety does not allow the starter to engage.	Decoder is losing power when key is placed in the start position.	Make sure PWR terminal has 12 volts when the key is in both the on and start positions.

GSS-1000 UNIVERSAL GEAR SHIFT SENDER LIMITED LIFETIME WARRANTY

DAKOTA DIGITAL, Inc. (the Company) warrants to the ORIGINAL PURCHASER of this product that should the included electronic decoder or sender modules under normal use and condition, be proven defective in material or workmanship DURING THE LIFETIME OF THE CAR IN WHICH IT WAS ORIGINALLY INSTALLED, such defect(s) will be repaired or replaced (at the Company's option) without charge for parts or labor directly related to repairs of the defect(s).

To obtain repair or replacement within the terms of this Warranty, the product is to be delivered with proof of warranty coverage (e.g. dated bill of sale), specification of defect(s), transportation prepaid, to the factory. This Warranty is valid for the original purchaser only and may not be transferred.

This Warranty does not extend to damage to vehicle electrical system. This Warranty does not apply to any product or part thereof which in the opinion of the Company has been damaged through alteration, improper installation, mishandling, misuse, neglect, or accident.

This Warranty is in lieu of all other express warranties or liabilities. ANY IMPLIED WARRANTIES, INCLUDING ANY IMPLIED WARRANTY OF MERCHANTABILITY, SHALL BE LIMITED TO THE DURATION OF THIS WRITTEN WARRANTY. ANY ACTION FOR BREACH OF ANY WARRANTY HEREUNDER INCLUDING ANY IMPLIED WARRANTY OF MERCHANTABILITY MUST BE BROUGHT WITHIN A PERIOD OF 30 MONTHS FROM DATE OF ORIGINAL PURCHASE. IN NO CASE SHALL THE COMPANY BE LIABLE FOR ANY CONSEQUENTIAL OR INCIDENTAL DAMAGES FOR BREACH OF THIS OR ANY OTHER WARRANTY, EXPRESSED OR IMPLIED, WHATSOEVER. No person or representative is authorized to assume for the Company any liability other than expressed herein in connection with the sale of this product.

The Company does not warrant that this product cannot be compromised or circumvented. THE EXTENT OF THE COMPANY'S LIABILITY UNDER THIS WARRANTY IS LIMITED TO THE REPAIR OR REPLACEMENT PROVIDED ABOVE AND, IN NO EVENT, SHALL THE COMPANY'S LIABILITY EXCEED THE PURCHASE PRICE PAID BY THE PURCHASER FOR THE PRODUCT.

Some states do not allow limitations on how long an implied warranty lasts or the exclusion or limitation if incidental or consequential damage so the above limitations or exclusion may not apply to you. This Warranty gives you specific legal rights and you may also have other rights which vary from state to state.

Dakota Digital

4510 W. 61ST St. N., Sioux Falls, SD 57107
Phone: (605) 332-6513 FAX: (605) 339-4106

www.dakotadigital.com
dakotasupport@dakotadigital.com