

Odyssey

Manufactured by **Dakota Digital**

HLY-1027 MINI TACHOMETER

Introduction:

The Odyssey gauge series from Dakota Digital, Inc. incorporates the reliability and quality of our standard gauges, along with several unique features and easy mounting. These features include:

- Weather-proof construction.
- Chrome trim.
- 300-9990 rpm range with 10 rpm resolution.
- User adjustable cylinder selection.
- A warning feature that flashes the gauge when the rpm exceeds a user adjustable setting.
- User adjustable warning point.
- Microprocessor stabilized readings.
- Night dimming with lens label lighting.
- High Visibility VFD display for sunlight readability.

The Odyssey tachometer will show the current engine speed in revolutions per minute x10. The resolution of the gauge is 10 rpm. If the engine rpm is 2000, the gauge will show 200. The update rate for the display is 2 times per second. The tachometer is adjustable for almost any gasoline engine. The warning limit can be set to a value between 2600 and 7600 in 100 rpm increments.

Operation:

The gauge needs only the PWR and GND terminals connected to light up. When the DIM terminal has 12 volts, it will dim the display to a preset level for night viewing. The SND terminal should be connected to the negative side of the coil or a tach output from an ignition module. When the SW terminal has 12 volts, the gauge will display the current rpm warning limit value. The SW terminal is also used for calibration.

Wiring:

- | | | |
|-----|---|---------------------------------------------------------------------|
| PWR | - | connect to a 12V accessory terminal for power. |
| GND | - | connect to a good ground point in the vehicle. |
| SND | - | connect to the tach signal (usually the negative side of the coil). |
| DIM | - | connect to the tail light circuit. |
| SW | - | connect to push-button switch or leave open. |

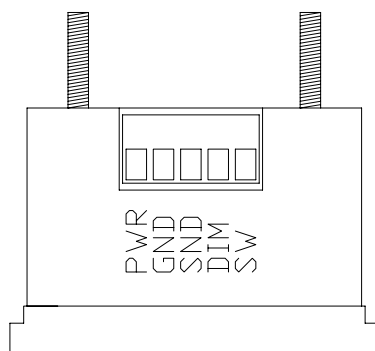

Setting for the number of engine cylinders and the warning limit:

The gauge can be set to work with almost any gasoline ignition system. Once it has been set, it is stored internally so that the gauge will retain the value even when the gauge does not have any power. This can be set and reset as many times as desired. The procedure for setting for the warning limit and the number of engine cylinders is as follows:

1. Make sure the key is off so the gauge is not powered.
2. Apply 12 volts to the SW terminal.
3. Turn the key on while the SW terminal is powered.
4. Disconnect the SW terminal. The gauge should show 'HI' and then switch to a reading between 26 and 76. This is the current warning x100.
5. Each time the SW terminal is momentarily powered it will increment the number by 1. Do this until the desired warning value is displayed.
6. Connect and hold power to the SW terminal for several seconds. The display will switch to "CYL".
7. Disconnect the SW terminal. The display will show the current cylinder setting.
8. Each time the SW terminal is momentarily powered it will increment the number by 1. Do this until the desired engine cylinder setting is displayed.
9. Connect and hold power to the SW terminal for several seconds. The display will switch to "—". Disconnect the SW terminal.
10. Turn the key off. The gauge will now operate normally when powered up again.

Mounting:

The gauge requires a rectangular cut out that is about 2 9/16" x 1 11/16". It should be inserted into the opening from the front and the U-clamp will be installed from the back. Tighten the two nuts on the U-clamp so that the gauge is secure. Figure 2 shows the required cut out for the gauge. Figure 3 shows how the gauge mounts.

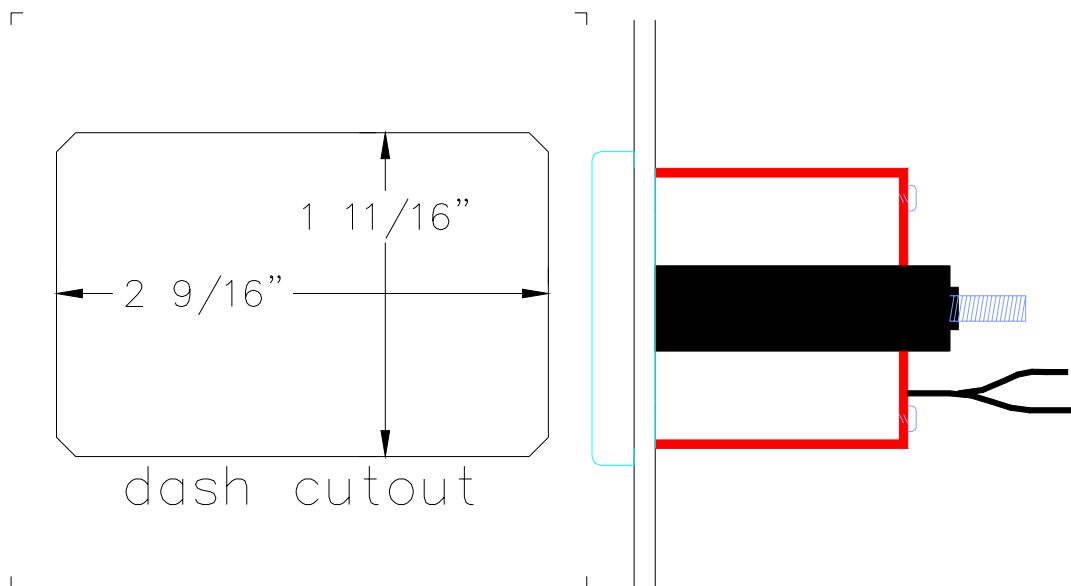

Troubleshooting guide.

Problem	Possible cause	Solution
Gauge will not light up	PWR terminal does not have power. GND terminal is not getting a good ground.	Connect to a location that has power. Connect ground to a different location.
Gauge lights up, but tach will only show zero.	Gauge is damaged. SND terminal is not connected properly. Gauge is not getting a tach signal from the engine.	Return gauge for repair. (see instructions) Check connection from SND terminal to the tach signal. Check location that the tach signal wire is connected at the ignition system.
Tach reading is erratic or jumps around.	Gauge is not calibrated Tach signal wire is loose or broken. Poor ground connection.	Gauge must be recalibrated (see instructions). Check all wire connections and inspect wire for breaks. Check ground connection on tachometer and ignition system.
Tach reading is incorrect.	Gauge is not calibrated correctly.	Gauge must be calibrated (see instructions).
Gauge will not dim.	DIM terminal is not connected correctly.	Check wiring connections. The DIM terminal have 12 volts with headlights on only.
Gauge remains dim at all times.	DIM terminal is getting power all of the time.	Connect DIM terminal to location that only has power when the headlights are on.

SERVICE AND REPAIR

DAKOTA DIGITAL offers complete service and repair of its product line. In addition, technical consultation is available to help you work through any questions or problems you may be having installing one of our units.

Should you ever need to send the unit back for repairs, please package the product in a good quality box along with plenty of packing material. Ship the product by UPS or insured Parcel Post. Be sure to include a complete description of the problem, your full name and address (street address preferred), and a telephone number where you can be reached during the day. An authorization number for products being returned for repair is not needed. Do not send any money. We will bill you for the repair charges. Any returns for warranty work must include a copy of the dated invoice or bill of sale.

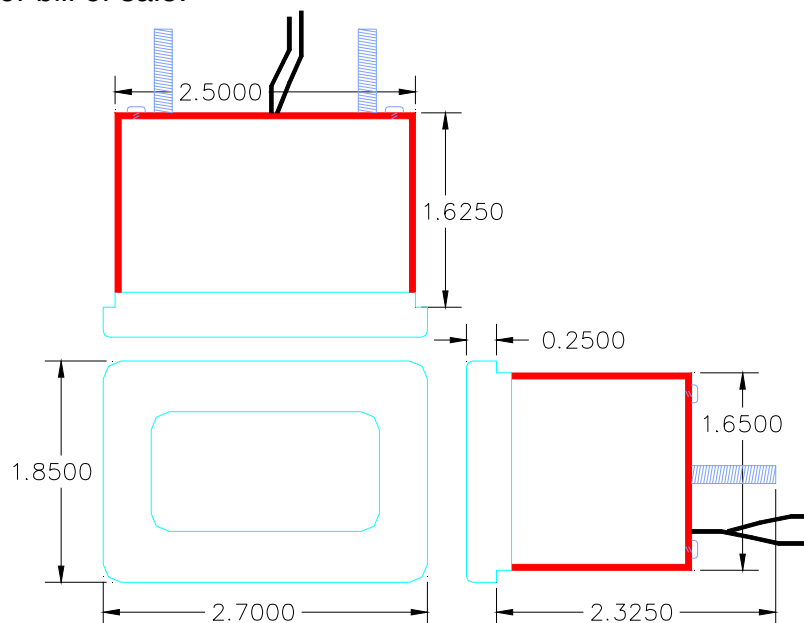

Technical specifications

Minimum operating voltage	-	7 volts
Maximum operating voltage	-	18 volts
(operating at or near maximum rating for an extended time can damage unit)		
Gauge Resolution	-	10 rpm
Gauge accuracy	-	±40 rpm
Digital readout update rate	-	1/2 second
Minimum rpm reading	-	300 rpm
Maximum rpm reading	-	9990 rpm
Warning Resolution	-	100 rpm
Cylinder select calibration range	-	1 to 15
Typical current draw (@ 13.8V)	-	0.13 A

ODYSSEY SERIES DIGITAL GAUGE LIMITED WARRANTY

DAKOTA DIGITAL (the Company) warrants to the ORIGINAL PURCHASER of this product that should it, under normal use and condition, be proven defective in material or workmanship within 24 MONTHS FROM THE DATE OF PURCHASE, such defect(s) will be repaired or replaced (at the Company's option) without charge for parts or labor directly related to repairs of the defect(s).

To obtain repair or replacement within the terms of this Warranty, the product is to be delivered with proof of warranty coverage (e.g. dated bill of sale), name, address, phone number, and specification of defects, transportation prepaid, to the factory. This Warranty is valid for the original purchaser only and may not be transferred.

This warranty does not cover nor extend to damage to vehicle electrical system. This Warranty does not apply to any product or part thereof which in the opinion of the Company has been damaged through alteration, improper installation, mishandling, misuse, neglect, or accident.

This Warranty is in lieu of all other express warranties or liabilities. ANY IMPLIED WARRANTIES, INCLUDING ANY IMPLIED WARRANTY OF MERCHANTABILITY, SHALL BE LIMITED TO THE DURATION OF THIS WRITTEN WARRANTY. ANY ACTION FOR BREACH OF ANY WARRANTY HEREUNDER INCLUDING ANY IMPLIED WARRANTY OF MERCHANTABILITY MUST BE BROUGHT WITHIN A PERIOD OF 24 MONTHS FROM DATE OF ORIGINAL PURCHASE. IN NO CASE SHALL THE COMPANY BE LIABLE FOR ANY CONSEQUENTIAL OR INCIDENTAL DAMAGES FOR BREACH OF THIS OR ANY OTHER WARRANTY, EXPRESSED OR IMPLIED, WHATSOEVER. No person or representative is authorized to assume for the Company any liability other than that expressed herein in connection with the sale of this product.

The Company does not warrant that this product cannot be compromised or circumvented. THE EXTENT OF THE COMPANY'S LIABILITY UNDER THIS WARRANTY IS LIMITED TO THE REPAIR OR REPLACEMENT PROVIDED ABOVE AND, IN NO EVENT, SHALL THE COMPANY'S LIABILITY EXCEED THE PURCHASE PRICE PAID TO THE PURCHASER FOR THE PRODUCT.

Some states do not allow limitations on how long an implied warranty lasts or the exclusion or limitation of incidental or consequential damage so the above limitations or exclusions may not apply to you. This warranty gives you specific legal rights and you may also have other rights which vary from state to state.

Dakota Digital

4510 W. 61ST St. N., Sioux Falls, SD 57107
Phone: (605) 332-6513 FAX: (605) 339-4106
www.dakotadigital.com
dakotasupport@dakotadigital.com