



Manufactured by **Dakota Digital**

HLY-1211 BAR GRAPH TACHOMETER

Introduction:

The Odyssey gauge series from Dakota Digital, Inc. incorporates the reliability and quality of our standard gauges, along with several unique features and easy mounting. These features include:

- Quick response bar graph display.
- Adjustable for different engines.
- Night dimming with lens label lighting.
- High Visibility VFD display for sunlight readability.
- Chrome bezel and weatherproof circuitry.

Operation:

The gauge needs the PWR and GND terminals connected to 12 volt power and ground respectively to light up. At zero rpm (no tach signal) there will be one bar lit. When the DIM terminal has 12 volts, it will dim the display for night viewing. The TCH terminal needs to be connected to the tachometer signal. If there is an ignition module with a tach output terminal, connect the TCH terminal to it. Otherwise connect the TCH terminal to the negative side of the coil.

Engine cylinder selection.

For 2 cylinder, single-fire (dual coil) ignition systems without a buffered tach output, connect the 4/1 terminal to 12 volts and connect the TCH terminal to the negative side of one of the coils. Leave the 8/4 terminal open.

For 2 cylinder, single-fire (dual coil) ignition systems with a buffered tach output from the ignition module, connect the TCH terminal to the tach output. Leave the 4/1 and 8/4 terminals open.

For 2 cylinder, dual-fire (single coil) ignition systems, connect the TCH terminal to the negative side of the coil. Leave the 4/1 and 8/4 terminals open.

Engine type	4/1	8/4
1 cylinder (2, single-fire)	12 volt	Open
2 cylinder	Open	Open
4 cylinder	12 volt	12 volt
8 cylinder	Open	12 volt

Wiring:

- PWR - connect to accessory, 12 volt power.
- DIM - connect to a switch for dimming.
- GND - connect to a good ground point.
- 8/4 - connect to 12V for 8 or 4 cylinder engines.
- 4/1 - connect to 12V for 4 or 1 cylinder engines.
- TCH - connect to the negative side of the coil or a tach output terminal.

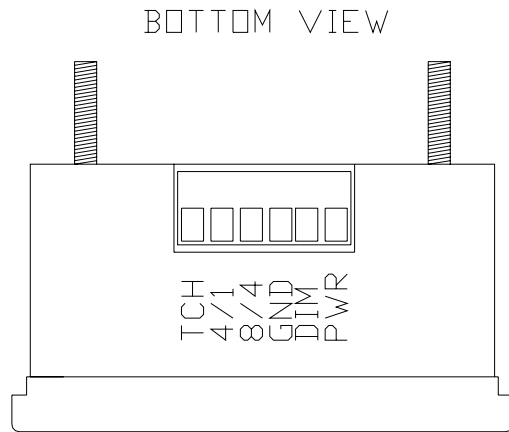

Mounting:

The gauge requires a rectangular cut out that is about 2 9/16" x 1 11/16". It should be inserted into the opening from the front and the U-clamp will be installed from the back. Tighten the two nuts on the U-clamp so that the gauge is secure. Figure 2 shows the required cut out for the gauge. Figure 3 shows how the gauge mounts.

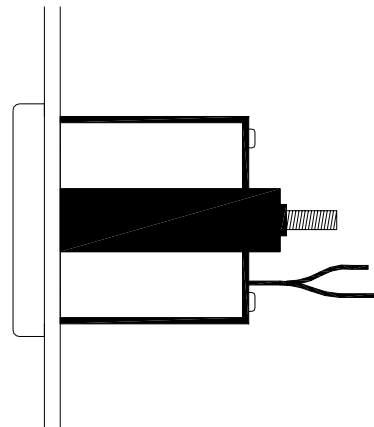
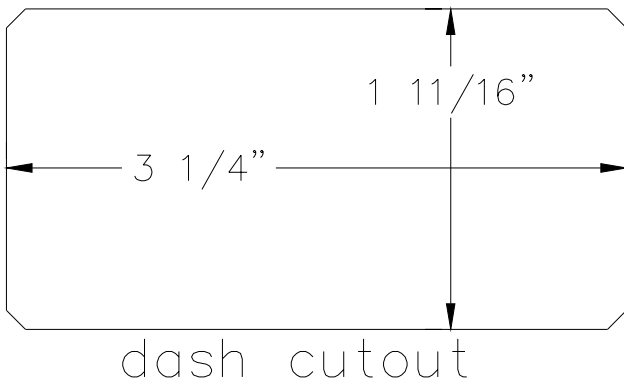

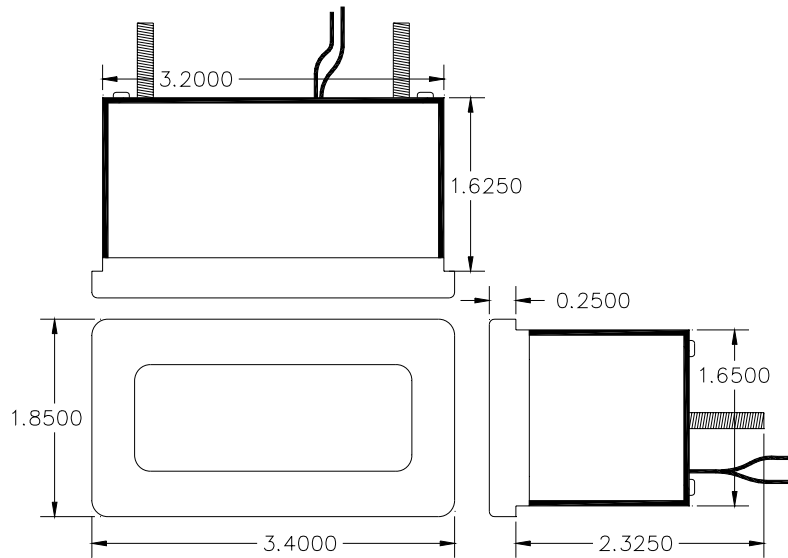

Troubleshooting guide.

Problem	Possible cause	Solution
Gauge will not light up	PWR terminal does not have power. GND terminal is not getting a good ground.	Connect to a location that has power. Connect ground to a different location.
Gauge lights up, but does not read correctly.	Gauge is damaged. Loose connection on PWR terminal. Poor ground connection. TCH terminal is not connected.	Return gauge for repair. (see instructions) Inspect connections and splices on power wire. Move ground to different location Make sure the TCH terminal is connected properly to the ignition system.
Gauge will not dim.	Engine type is not set properly. Voltage or wiring problem in vehicle wiring harness. DIM terminal is not connected correctly.	Check the 4/1 and 8/4 connections. Check wiring harness for loose or damaged wires. Check wiring connections.
Gauge remains dim at all times.	DIM terminal is getting power all of the time. Battery is very low. Gauge is damaged.	Connect DIM terminal to location that only has power when the headlights are on. Recharge or replace vehicle battery. Return gauge for repair. (contact factory)

SERVICE AND REPAIR

DAKOTA DIGITAL offers complete service and repair of its product line. In addition, technical consultation is available to help you work through any questions or problems you may be having installing one of our units.

Should you ever need to send the unit back for repairs, please package the product in a good quality box along with plenty of packing material. Ship the product by UPS or insured Parcel Post. Be sure to include a complete description of the problem, your full name and address (street address preferred), and a telephone number where you can be reached during the day. An authorization number for products being returned for repair is not needed. Do not send any money. We will bill you for the repair charges. Any returns for warranty work must include a copy of the dated invoice or bill of sale.

Technical specifications

Minimum operating voltage	-	7 volts
Maximum operating voltage	-	18 volts
(operating at or near maximum rating for an extended time can damage unit)		
Typical current draw (@ 13.8V)	-	0.13 A
Gauge Resolution	-	160 rpm per bar
Gauge Range	-	8000 rpm

ODYSSEY SERIES DIGITAL GAUGE LIMITED WARRANTY

DAKOTA DIGITAL (the Company) warrants to the ORIGINAL PURCHASER of this product that should it, under normal use and condition, be proven defective in material or workmanship within 24 MONTHS FROM THE DATE OF PURCHASE, such defect(s) will be repaired or replaced (at the Company's option) without charge for parts or labor directly related to repairs of the defect(s).

To obtain repair or replacement within the terms of this Warranty, the product is to be delivered with proof of warranty coverage (e.g. dated bill of sale), name, address, phone number, and specification of defects, transportation prepaid, to the factory. This Warranty is valid for the original purchaser only and may not be transferred.

This warranty does not cover nor extend to damage to vehicle electrical system. This Warranty does not apply to any product or part thereof which in the opinion of the Company has been damaged through alteration, improper installation, mishandling, misuse, neglect, or accident.

This Warranty is in lieu of all other express warranties or liabilities. ANY IMPLIED WARRANTIES, INCLUDING ANY IMPLIED WARRANTY OF MERCHANTABILITY, SHALL BE LIMITED TO THE DURATION OF THIS WRITTEN WARRANTY. ANY ACTION FOR BREACH OF ANY WARRANTY HEREUNDER INCLUDING ANY IMPLIED WARRANTY OF MERCHANTABILITY MUST BE BROUGHT WITHIN A PERIOD OF 24 MONTHS FROM DATE OF ORIGINAL PURCHASE. IN NO CASE SHALL THE COMPANY BE LIABLE FOR ANY CONSEQUENTIAL OR INCIDENTAL DAMAGES FOR BREACH OF THIS OR ANY OTHER WARRANTY, EXPRESSED OR IMPLIED, WHATSOEVER. No person or representative is authorized to assume for the Company any liability other than that expressed herein in connection with the sale of this product.

The Company does not warrant that this product cannot be compromised or circumvented. THE EXTENT OF THE COMPANY'S LIABILITY UNDER THIS WARRANTY IS LIMITED TO THE REPAIR OR REPLACEMENT PROVIDED ABOVE AND, IN NO EVENT, SHALL THE COMPANY'S LIABILITY EXCEED THE PURCHASE PRICE PAID TO THE PURCHASER FOR THE PRODUCT.

Some states do not allow limitations on how long an implied warranty lasts or the exclusion or limitation if incidental or consequential damage so the above limitations or exclusions may not apply to you. This warranty gives you specific legal rights and you may also have other rights which vary from state to state.

Dakota Digital

4510 W. 61ST St. N., Sioux Falls, SD 57107
Phone: (605) 332-6513 FAX: (605) 339-4106

www.dakotadigital.com
dakotasupport@dakotadigital.com