



Series I
ODY-09-5 VACUUM/BOOST GAUGE
with SEN-09-5 SENSOR

Wiring: ODY-09-5

GND	-	connect to a main ground location
PWR	-	connect to 12 volt power (An accessory circuit will work for this.)
DIM	-	connect to the tail light circuit (When terminal has +12V, gauge will dim)
SND	-	connect to the WHITE wire from the SEN-09-5 harness

Wiring: SEN-09-5

RED	-	connect to accessory power (+12V power or along with PWR terminal at gauge)
BLACK	-	connect to gauge ground
SILVER/BARE	-	shield wire, connect to gauge ground
WHITE	-	connect to the gauge SND terminal

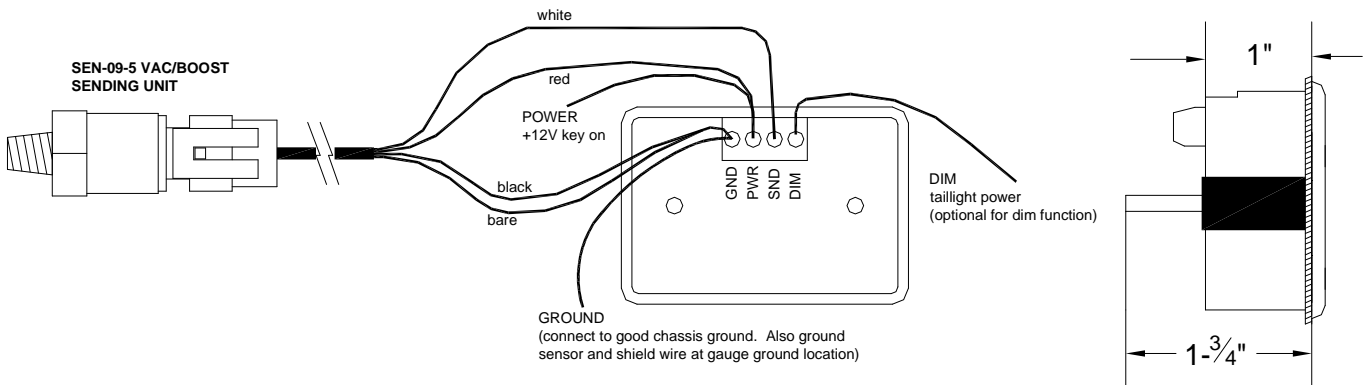

Default settings: Fast update, Warning 82.5 psi, “Zero” pressure is 14.2 PSIA

- The vacuum/boost gauge will operate and read correctly between the range of - 30 inHg to 80 psi.
- The gauge has a user adjustable warning level and update rate.
- The gauge also has a self calibration that will adjust for changes in elevation on power up.

Mounting:

The ODY Series II gauge requires a rectangular hole 2-1/2” x 1-11/16” for mounting. It should be inserted into the opening from the front and the U-clamp will be installed from the back. Tighten the two nuts on the U-clamp so that the gauge is secure. Gauge depth to the back of the case is 1”. Gauge depth including the mounting studs is 1-3/4”.

Sensor (SEN-09-5):

The vac./boost sensor, SEN-09-5, has 1/8” NPT thread on the end which can be threaded into the intake track, or wherever you would like to reference boost pressure from. An 1/8” NPT to 1/8” barbed adaptor is also supplied so you can T-into a convenient vac./boost line for connection to the sensor. The sensor should be connected to the control unit as follows:

RED	-	Connect to control unit PWR terminal
WHITE	-	Connect to control unit SND terminal
BLACK	-	Connect to control unit GND terminal

The sender must be Dakota Digital part SEN-09-5. Sending units from other manufacturers will cause incorrect readings. If a sender is not connected properly, the display will show “----”.

The supplied boost sensor measures atmospheric pressure, the gauge then calculates appropriate boost or vacuum readings based on the “zero” point. The “zero” point, that all of the calculations are based on, is automatically set when the gauge is turned on, and is just the current atmospheric pressure the sensor reads. The “zero” point insures accurate boost readings at various elevations and weather conditions.

To reset the zero point for the current elevation, turn the key on without starting the engine and wait for at least 20 seconds. After 15 seconds of seeing less than 0.4 psi change in the vac/boost reading the gauge will show “-0-”, the gauge is saving the new “zero” point. After 20 seconds the new zero value will be saved and the gauge will begin normal operation displaying “0.0”.

Boost readings:

The display will display current boost reading in pounds per square inch only, psi. The boost pressure is displayed as a positive number with 0.2 psi resolution. "12.0" would represent 12 psi of pressure.

Vacuum readings:

The label of the gauge reads "BOOST" all of the time, but it will read down to about 30 inHg due to the nature of the sensor. All vacuum readings are displayed with a negative sign in front of the number, 20 inHg would read "-20".

Setting the warning limits, gauge setup, and update speed:

*****NOTE: The sensor should be disconnected from the gauge during setup or damage to the sensor could occur, reconnect the sensor to the SND terminal once setup is complete.**

The SND terminal is used to enter and change the warning settings. You will need a wire connected to the SND terminal that can be momentarily powered (+12V) while you watch the gauge; make sure the sensor is disconnected from the "SND" terminal for setup. The headlights should be off or the DIM terminal unhooked so that it does not interfere with the setup.

1. To enter the set mode, turn the key on with the SND wire not touching anything. The gauge will display "SET".
2. Power the SND wire. The gauge will display "SPd". (If you wait too long the gauge will exit the setup routine and you will need to repeat step #1).
3. Release the SND wire. The gauge will display the current update speed. ("SLD" for slow, "F5t" for fast, and "HLd" for peak hold)
4. Each time you momentarily power the SND wire the setup will change.
5. When the desired update speed is displayed, keep the SND wire powered for about 2 seconds. The gauge will display "H I".
6. Release the SND wire. The gauge will display the current high warning value (7.5 – 82.5 in 2.5 psi increments).
7. Each time you momentarily power the SND wire the number will change.
8. When the desired high warning value is displayed, keep the SND wire powered for about 2 seconds. The gauge will display "- 0-".
9. Release the SND wire. The gauge will display the current zero setting. This is the atmospheric pressure. This is what the gauge uses to calculate the boost value from, default is 14.2
10. Turn the key off.

Troubleshooting Guide

Problem	Possible cause	Solution
Gauge will not light up	PWR terminal does not have power. GND terminal does not have a good ground. Gauge is damaged.	Connect to a location that has power. Connect to a different ground location. Return gauge for service. (see instructions)
Gauge lights up, but does not read correctly.	Loose connection on SND terminal. Poor ground connection. Zero point is incorrect. Voltage or wiring problem in the vehicle wiring harness.	Reconnect wire. Move ground to different location See sensor section for auto "zero" calibration. Check wiring harness for loose or damaged wires.
Gauge lights up, but displays "Er3"	Gauge calibration is incorrect.	Gauge must be returned for service. (see instructions)
Gauge lights up, but displays "..."	SND terminal is shorted to ground. Sender is damaged. Sender is not connected to gauge. Wire between gauge and sender is broken. Sender is damaged. Gauge is damaged.	Check wire for damaged insulation. Replace if necessary. Replace sender. Connect SND terminal on gauge to sender terminal. Test and replace wire. Replace sender. Return gauge for service. (see instructions)
Gauge lights up, but displays "Er4"	Gauge update rate incorrect.	Follow setup procedure in the manual.
Gauge lights up, but displays "Er5"	Gauge warning points need to be reset.	See "Setting the warning limits" in the manual.
Gauge flashes constantly.	Warning limits are not set properly. Pressure is too low or too high.	Reset warning limits. Check engine.
Gauge will not dim.	DIM terminal is not connected correctly.	Check wiring connections.
Gauge remains dim at all times.	DIM terminal is getting power all of the time. Battery is very low. Gauge is damaged.	Connect DIM wire to location that only has power when the headlights are on. Recharge or replace vehicle battery. Return gauge for service. (see instructions)

Technical specifications

- Minimum operating voltage - 7 VDC
- Maximum operating voltage - 17 VDC
(operating at or near maximum voltage for an extended time can damage unit)
- Maximum pressure reading - 85 psi (maximum reading is dependent on elevation)
- Maximum vacuum reading - 30 inHg
- Gauge Resolution - .2psi/1inHg
- Warning Range - 7.5 – 82.5
- Typical gauge accuracy - ±1%
- Typical current draw (@ 13.8V) - 0.1 A

SERVICE AND REPAIR

DAKOTA DIGITAL offers complete service and repair of its product line. In addition, technical consultation is available to help you work through any questions or problems you may be having installing one of our products. Please read through the Troubleshooting Guide. There, you will find the solution to most problems.

Should you ever need to send the unit back for repairs, please call our technical support line, (605) 332-6513, to request a Return Merchandise Authorization number. Package the product in a good quality box along with plenty of packing material. Ship the product by UPS or insured Parcel Post. Be sure to include the RMA number on the package, and include a complete description of the problem with RMA number, your full name and address (street address preferred), and a telephone number where you can be reached during the day. Any returns for warranty work must include a copy of the dated sales receipt from your place of purchase. Send no money. We will bill you after repair.

Dakota Digital 24 Month Warranty

DAKOTA DIGITAL warrants to the ORIGINAL PURCHASER of this product that should it, under normal use and condition, be proven defective in material or workmanship within 24 MONTHS FROM THE DATE OF PURCHASE, such defect(s) will be repaired or replaced at Dakota Digital's option.

This warranty does not cover nor extend to damage to the vehicle's systems, and does not cover removal or reinstallation of the product. This Warranty does not apply to any product or part thereof which in the opinion of the Company has been damaged through alteration, improper installation, mishandling, misuse, neglect, or accident.

This Warranty is in lieu of all other expressed warranties or liabilities. Any implied warranties, including any implied warranty of merchantability, shall be limited to the duration of this written warranty. Any action for breach of any warranty hereunder, including any implied warranty of merchantability, must be brought within a period of 24 months from date of original purchase. No person or representative is authorized to assume, for Dakota Digital, any liability other than expressed herein in connection with the sale of this product.



4510 W. 61st St. N., Sioux Falls SD 57107
Phone: (605) 332-6513 Fax: (605) 339-4106
www.dakotadigital.com
dakotasupport@dakotadigital.com

©Copyright 2010 Dakota Digital Inc.