



Series I

ODY-14 INSIDE/OUTSIDE TEMPERATURE rev. C ODY-15 AMP TEMPERATURE rev. C

Wiring:

- GND - Connect to a main ground location and to the BLACK wire from sensor.
- PWR - Connect to fused switched 12 VDC power. (An accessory terminal will work for this.)
- DIM - Night Dimming: connect to the head light switch (+12V w/headlights on).
- SND - Connect to the RED wire from temperature sensor.

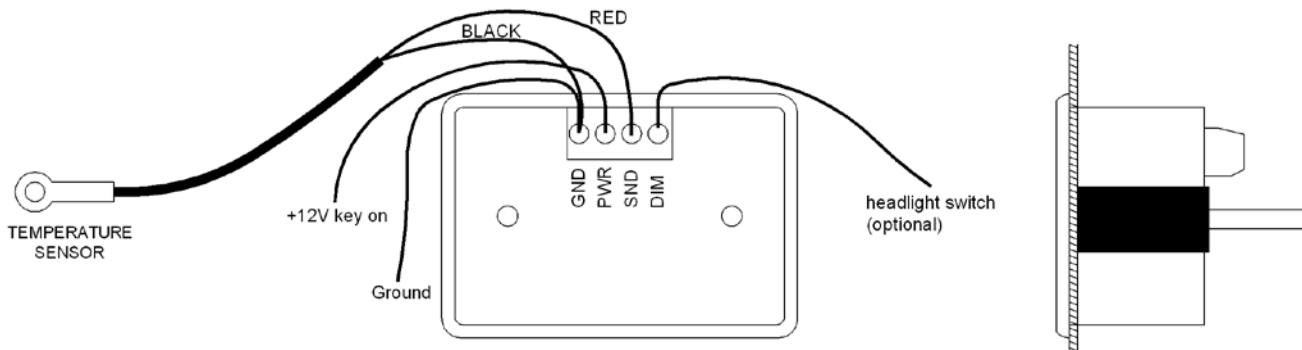

Mounting:

The Series I gauge requires a rectangular hole 2-9/16" x 1-11/16". . It should be inserted into the opening from the front and the U-clamp will be installed from the back. Tighten the two nuts on the U-clamp so that the gauge is secure. Gauge depth to the back of the case is 1". Gauge depth including the mounting studs is 1-7/8".

Factory settings:

- Temperature unit: °F.
- Hi warning point: 175 °F.
- Lo warning point: 18 °F.

- The temperature gauge will operate and read correctly between the temperature range of -40 - 255° F (-40 - 125°C).
- This gauge has a user adjustable low and high warning level, which can be set to indicate when the temperature is too high to too low.

The sender must be Dakota Digital part SEN-15-1. Sending units from other manufacturers will cause incorrect readings.

The sensor will measure the temperature where its probe is located. The sensor has a 12' two wire cable to connect it to the gauge. This cable can be shortened or additional wire can be added. If additional wire is added, the added wire pair should be twisted and polarity of the wires should be carefully noted. If the probe temperature is below -39° the display will show "—". If a sender is not connected properly, the display will show "EEE". If the SND terminal is shorted to ground, the display will show "---".

For outside temperature sensing, the best location will be in the front grill or another location at the front of the vehicle where it will have good air flow while the vehicle is moving. Do not mount the sensor too close to the engine or exhaust. Doing so will cause the temperature reading to be much higher than the actual outside temperature. Please note that with the sensor mounted in the front grill the temperature will be very accurate while the vehicle is moving, but the temperature will rise when the vehicle is sitting still. This is due to the engine heat radiating forward.

For inside temperature sensing, keep the sensor away from heating and A/C vents. Having these blowing on the sensor will cause inaccurate readings of the actual vehicle cabin temperature. Also keep sensor away from any heat generating electrical components.

The amp temperature gauge will read the amplifier case temperature from a remote sensor. The sensor should be secured to the case of the amplifier that is to be monitored. If the amp has forced air cooling it, then mount the sensor on the side opposite the air source. This will provide the highest case temperature reading. The amp temperature gauge will operate and read correctly between the temperature range of -39 - 255° F (-39 - 125°C). The gauge has a user adjustable low and high warning level. This can be set to indicate when the temperature is outside a set range.

Setting the warning limits and sender setup:

The SND terminal is used to enter and change the warning settings. Make sure the sensor is disconnected from the gauge before attempting to enter setup. You will need a wire connected to the SND terminal that can be momentarily grounded while you watch the gauge. The headlights should be off or the DIM terminal unhooked so that it does not interfere with the setup.

1. To enter the set mode, turn the key on with the SND wire disconnected from the sensor and not grounded. The gauge will display "SEt".
2. Ground the SND wire. The gauge will display "F" for Fahrenheit or "C" for Celsius. (If you wait too long the gauge will exit the setup routine and you will need to repeat step #1).
3. Release the SND wire. Each time you momentarily ground the SND wire the temperature unit will change.
4. When the desired unit value is displayed, keep the SND wire grounded for about 2 seconds. The gauge will display "HI".
5. Release the SND wire. The gauge will display a number between 121 - 229 (50 - 110°C).
6. Each time you momentarily ground the SND wire the number will change.
7. When the desired high warning value is displayed, keep the SND wire grounded for about 2 seconds. The gauge will display "LO".
8. Release the SND wire. The gauge will display a number between -36 - 71 (-38 - 22°C).
9. Each time you momentarily ground the SND wire the number will change.
10. When the desired low warning value is displayed, keep the SND wire grounded for about 2 seconds. The gauge will display "--".
11. Turn the key off.

Troubleshooting guide.

Problem	Possible cause	Solution
Gauge will not light up	PWR terminal does not have power. GND terminal does not have a good ground.	Connect to a location that has power. Connect to a different ground location.
Gauge lights up, but does not read correctly.	Gauge is damaged. Loose connection on SND terminal. Poor ground connection. Gauge sender setup is incorrect. Improper sensor location. Voltage or wiring problem in the vehicle wiring harness.	Return gauge for service. (see instructions) Reconnect wire. Move ground to different location See "Setting sender setup" in the manual. Move sensor to a different location. Check wiring harness for loose or damaged wires.
Gauge lights up, but displays "Er0".	Gauge is damaged.	Gauge must be returned for service. (see instructions)
Gauge lights up, but displays "---".	SND terminal is shorted to ground. Sender is damaged.	Check wire for damaged insulation. Replace if necessary. Replace sender.
Gauge lights up, but displays "EEE".	Sender is not connected to gauge. Wire between gauge and sender is broken. Sender is damaged. Gauge is damaged.	Connect SND terminal on gauge to sender terminal. Test and replace wire. Replace sender. Return gauge for service. (see instructions)
Gauge lights up, but displays "Er4".	Gauge sender setup needs to be reset.	See "Setting sender setup" in the manual.
Gauge lights up, but displays "Er5".	Gauge warning points need to be reset.	See "Setting the warning limits" in the manual.
Gauge flashes constantly.	Warning limits are not set properly. Temperature is too high or too low.	Reset warning limits.
Gauge will not dim.	DIM terminal is not connected correctly.	Check wiring connections.
Gauge remains dim at all times.	DIM terminal is getting power all of the time. Battery is very low. Gauge is damaged.	Connect DIM wire to location that only has power when the headlights are on (typically a park light circuit). Recharge or replace vehicle battery. Return gauge for service. (see instructions)

Technical specifications

Minimum operating voltage	-	7 VDC
Maximum operating voltage	-	17 VDC
(operating at or near maximum voltage for an extended time can damage unit)		
Maximum temperature reading	-	255°F (125°C)
Gauge Resolution	-	1°F (1°C)
Gauge accuracy	-	±2°F (±1°C)
High Warning Range	-	121 - 229 (50 - 110°C)
Low Warning Range	-	-36 - 71 (-38 - 22°C)
Typical current draw (@ 13.8V)	-	0.1 A

SERVICE AND REPAIR

DAKOTA DIGITAL offers complete service and repair of its product line. In addition, technical consultation is available to help you work through any questions or problems you may be having installing one of our products. Please read through the Troubleshooting Guide. There, you will find the solution to most problems.

Should you ever need to send the unit back for repairs, please call our technical support line, (605) 332-6513, to request a Return Merchandise Authorization number. Package the product in a good quality box along with plenty of packing material. Ship the product by UPS or insured Parcel Post. Be sure to include the RMA number on the package, and include a complete description of the problem with RMA number, your full name and address (street address preferred), and a telephone number where you can be reached during the day. Any returns for warranty work must include a copy of the dated sales receipt from your place of purchase. Send no money. We will bill you after repair.

Dakota Digital 24 Month Warranty

DAKOTA DIGITAL warrants to the ORIGINAL PURCHASER of this product that should it, under normal use and condition, be proven defective in material or workmanship within 24 MONTHS FROM THE DATE OF PURCHASE, such defect(s) will be repaired or replaced at Dakota Digital's option.

This warranty does not cover nor extend to damage to the vehicle's systems, and does not cover removal or reinstallation of the product. This Warranty does not apply to any product or part thereof which in the opinion of the Company has been damaged through alteration, improper installation, mishandling, misuse, neglect, or accident.

This Warranty is in lieu of all other expressed warranties or liabilities. Any implied warranties, including any implied warranty of merchantability, shall be limited to the duration of this written warranty. Any action for breach of any warranty hereunder, including any implied warranty of merchantability, must be brought within a period of 24 months from date of original purchase. No person or representative is authorized to assume, for Dakota Digital, any liability other than expressed herein in connection with the sale of this product.

Dakota Digital

4510 W. 61st St. N, Sioux Falls, SD. 57107
Phone: (605) 332-6513 FAX: (605) 339-4106
www.dakotadigital.com
dakotasupport@dakotadigital.com

©Copyright 2004 Dakota Digital Inc.