

Dakota Digital

SGI-5 rev. C

UNIVERSAL SIGNAL INTERFACE UNIT

The Dakota Digital SGI-5 is designed to recalibrate a speedometer signal or correct sinewave(AC)/squarewave('oc') signal incompatibilities. Here are some typical applications:

1. Recalibrate a high speed (64,000ppm – 250,000ppm) signal for an OEM speedometer. **Do not use this unit to adjust a signal going to an anti-lock braking system.**
2. Recalibrate a low speed (8000ppm – 4000ppm) signal for an OEM or aftermarket speedometer or fuel injection computer.
3. Convert a high-speed signal found on newer GM transmissions down to a low speed signal to run a speedometer, cruise control, or fuel injection computer.
4. Convert an 8000ppm signal from an aftermarket signal generator to a 4000ppm or 2000ppm to run an OEM cruise control or fuel injection computer.
5. Convert a 16000ppm signal from a VDO Hall Effect signal generator to an 8000ppm, 4000ppm, or 2000ppm to run a cruise control or fuel injection computer.
6. Convert a 4000ppm signal from an OEM transmission speed sensor or ECM output to an 8000ppm signal for an aftermarket speedometer.

SGI-5 wiring connections:

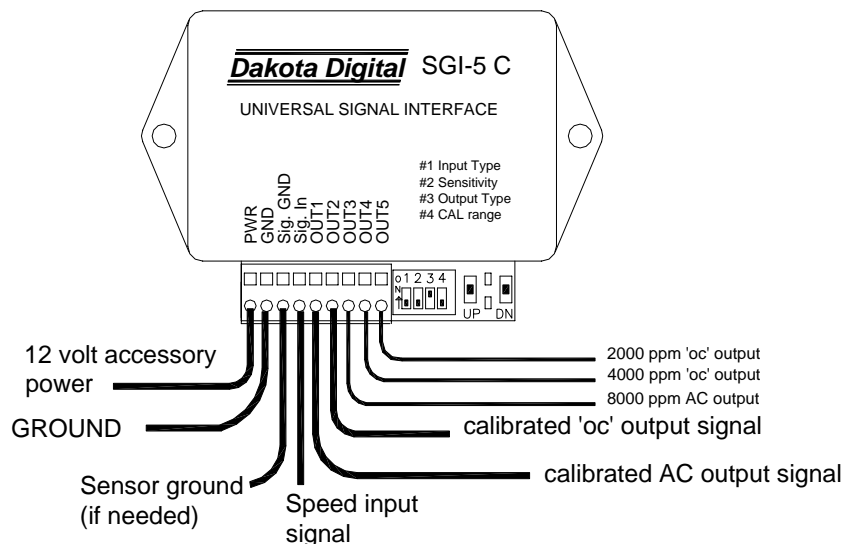

Please Note: This is a technically advanced product and if not installed correctly may cause incorrect vehicle operation and/or damage to vehicle components.

Setup tips:

- If, without the interface, your speedometer reads much too fast, then you will most likely need to use application 3.
- If, without the interface, your speedometer reads about ½ what it should, then you will most likely need to use application 6.
- If your speedometer reads close to actual speed, you will probably need application 1 or 2.

Here is a general overview of the SGI-5’s control functions.

Each of the different applications below will be described in detail starting on page 4 in this manual.

The unit has 4 switches on it for setting the calibration and signal type.

Switch #	OFF	ON
1	Signal generator speed input	ECM/PCM speed input
2	High sensitivity	Low sensitivity
3	OUT3/4/5 set for low speed in	OUT3/4/5 set for high speed in
4	Slower output	Faster output

There are also 2 push button switches for adjusting the calibration. The calibration can be adjusted two ways, while driving or while standing still.

	While operating	While turning key on
UP	Increase speed	Enter coarse adjust
DN	Decrease speed	Enter fine adjust

The unit has 5 different outputs for speed signals. Some of the outputs are AC (a voltage output that goes above and below ground) and some are open collector (a switch that closes to ground). The output functions are as follows:

SW #3	Sig In	OUT1	OUT2	OUT3	OUT4	OUT5
ON	64k-256k	128k AC	128k oc	8000 AC	4000 oc	2000 oc
OFF	4k-16k	8000 AC	8000 oc	4000 AC	4000 oc	2000 oc

Setup and diagnostic lights

RED	GREEN	Status
OFF	OFF	Power off.
OFF	ON	Power on, no speed signal present
OFF	Flashing	Power on, speed signal present
ON	Flashing	Coarse calibration adjustment mode
Flashing	ON	Fine calibration adjustment mode
ON	ON	Both switches held to preset cal
ON	OFF	One switch is being held to enter setup mode

Calibration

Adjust while driving: To increase the speedometer reading, press and hold the UP push button switch. To decrease the speedometer reading, press and hold the DN push button switch. If you cannot get the speedometer to read fast enough, make sure that setup switch #4 is ON. If you cannot get the speedometer to read slow enough, make sure that setup switch #4 is OFF or move to a different output.

Preset or adjust while parked: The calibration table is listed at the back of the installation manual. There is a coarse adjust setting and a fine adjust setting.

To check or change the coarse adjust setting:

1. Begin with the key off.
2. Press and hold the UP switch while turning the key on. The RED light should be on.
3. Release the UP switch. The GREEN light will begin flashing the current coarse setting. It will flash the current setting, wait, flash the current setting, wait, etc.
4. To increase the setting, press and release the UP switch. To decrease the setting, press and release the DN switch.
5. When the GREEN light flashes the correct number of times, turn the key off.

To check or change the fine adjust setting:

1. Begin with the key off.
2. Press and hold the DN switch while turning the key on. The RED light should be on.
3. Release the DN switch. The GREEN light will come on steady and the RED light will begin flashing the current fine setting. It will flash the current setting, wait, flash the current setting, wait, etc.
4. To increase the setting, press and release the UP switch. To decrease the setting, press and release the DN switch.
5. When the RED light flashes the correct number of times, turn the key off.

Quick preset: Hold both UP and DN push buttons while turning the key on.

- | | |
|----------------|---|
| Set to x1.004: | Turn setup switch #3 off, #4 on, hold both buttons while turning key on. |
| Set to x1.000: | Turn setup switch #3 off, #4 off, hold both buttons while turning key on. |
| Set to x2.0: | Turn setup switch #3 on, #4 on, hold both buttons while turning key on. |
| Set to x0.5: | Turn setup switch #3 on, #4 off, hold both buttons while turning key on. |

APPLICATION #1

Recalibrate a high speed (64,000ppm – 250,000ppm) signal for an OEM speedometer or engine/transmission computer. **Do not use this unit to adjust a signal going to an anti-lock braking system.** Anti-lock braking systems may not operate correctly or behave erratically due to the signal processing done to recalibrate the speed signal.

These speed sensors have a two-pin connector that plugs into the transmission or transfer case. One of the wires will be a ground and the other will be the signal wire. The wires will usually go up under the dash and into the speedometer, vehicle speed buffer, or engine/transmission computer. The signal wire will need to be cut so the SGI-5 can recalibrate it. The sensor side of the wire will go to the SIG IN terminal. The speedometer or buffer side will go to the OUT1 terminal. If the speedometer does not operate correctly after installation of the SGI-5 you may need to switch to OUT2 instead of OUT1. Connect the PWR terminal to a 12-volt accessory wire and connect the GND terminal to a good ground location.

Begin with the switches as follows and then determine how far off the calibration is.

1	2	3	4
OFF	OFF	ON	OFF

You can determine how far the speedometer is off by having it checked with radar or following another vehicle going at a set speed. Once you know how far it is off at a certain speed, you can use the push button switches to adjust the speedometer while you drive or use the following equation and then look up the calibration setting in the table.

$$\frac{\text{Actual speed}}{\text{speedometer reading}} \times \text{current Cal ratio} = \text{new Cal ratio}$$

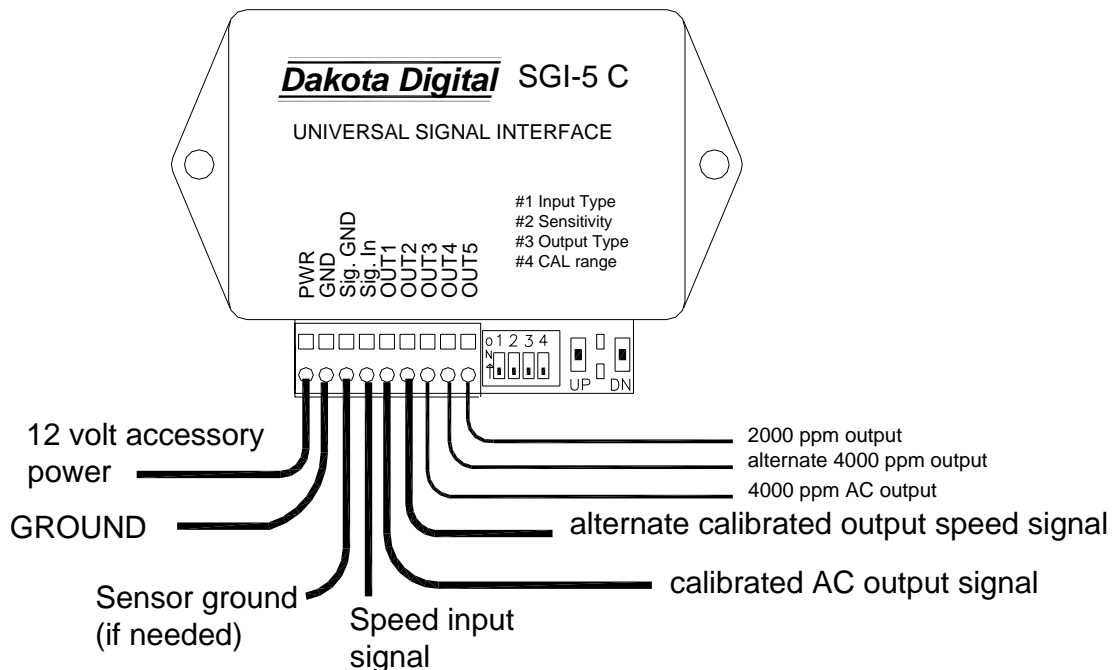

APPLICATION #2

Recalibrate a low speed (8000ppm – 4000ppm) signal for an OEM or aftermarket speedometer or fuel injection computer.

Either two wire or three wire sensors can be recalibrated with this unit. Two wire sensors will typically have one wire as a ground and the other as the signal. Three wire sensors will have an additional power wire. You must first determine which wire is the signal. The signal wire will need to be cut so the SGI-5 can recalibrate it. The sensor side of the wire will go to the SIG IN terminal. The speedometer or computer side will go to the OUT1 terminal. If the speedometer does not operate correctly after installation of the SGI-5 you may need to switch to OUT2 instead of OUT1. Connect the PWR terminal to a 12-volt accessory wire and connect the GND terminal to a good ground location.

Begin with the switches as follows and then determine how far off the calibration is.

1	2	3	4
OFF	OFF	OFF	OFF

You can determine how far the speedometer is off by having it checked with radar or following another vehicle going at a set speed. Once you know how far it is off at a certain speed, you can use the push button switches to adjust the speedometer while you drive or use the following equation and then look up the calibration setting in the table.

$$\frac{\text{Actual speed}}{\text{speedometer reading}} \times \text{current Cal ratio} = \text{new Cal ratio}$$

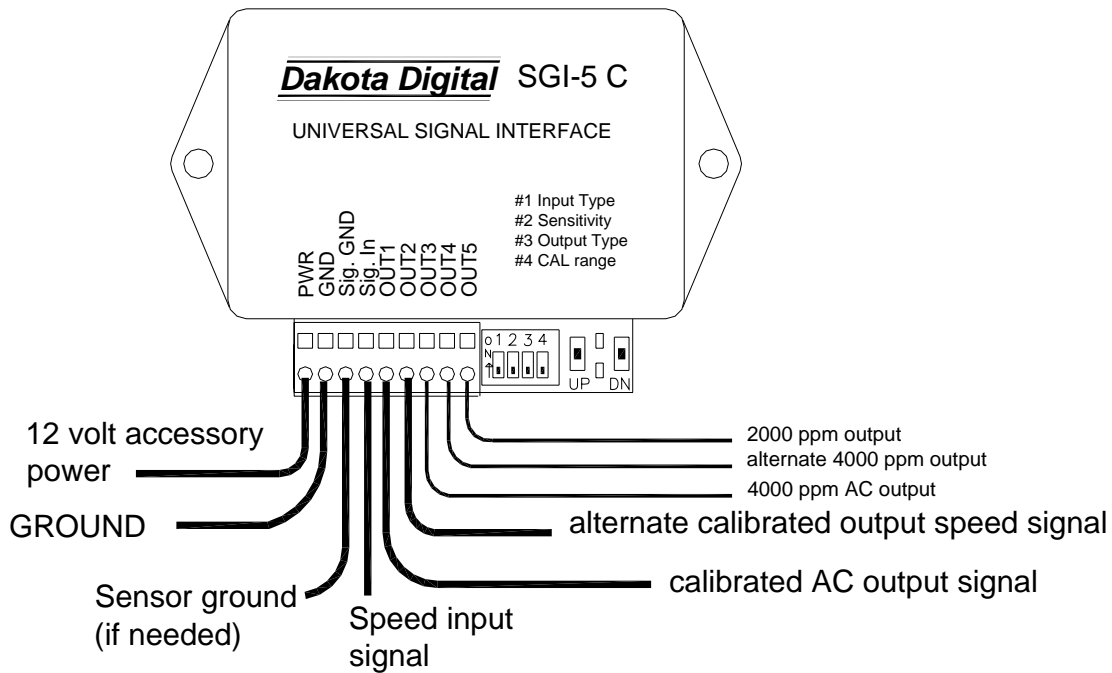

APPLICATION #3

Convert a high-speed signal found on newer GM transmissions down to a low speed signal to run a speedometer, cruise control, or fuel injection computer.

These speed sensors have a two-pin connector on the transmission or transfer case. One of the pins will be a ground and the other will be the signal. The ground pin will go to the GND terminal along with the ground wire. The signal pin will go to the SIG IN terminal. It is best to twist the signal and ground wires from the sensor around each other. This helps eliminate any electrical interference. If nothing else is connected to the speed sensor it does not matter which pin is used as the ground. Connect the PWR terminal to accessory power. The output connections will depend on your particular application. Here are some typical examples:

- OUT3, 8000ppm AC: most aftermarket speedometers and cruise controls
- OUT4, 4000ppm oc: most TPI computers and some OEM cruise controls
- OUT5, 2000ppm oc: most TBI computers and some OEM cruise controls

Begin with the switches as follows and then determine how far off the calibration is.

1	2	3	4
OFF	OFF	ON	OFF

You can determine how far the speedometer is off by having it checked with radar or following another vehicle going at a set speed. Once you know how far it is off at a certain speed, you can use the push button switches to adjust the speedometer while you drive or use the following equation and then look up the calibration setting in the table.

$$\frac{\text{Actual speed}}{\text{speedometer reading}} \times \text{current Cal ratio} = \text{new Cal ratio}$$

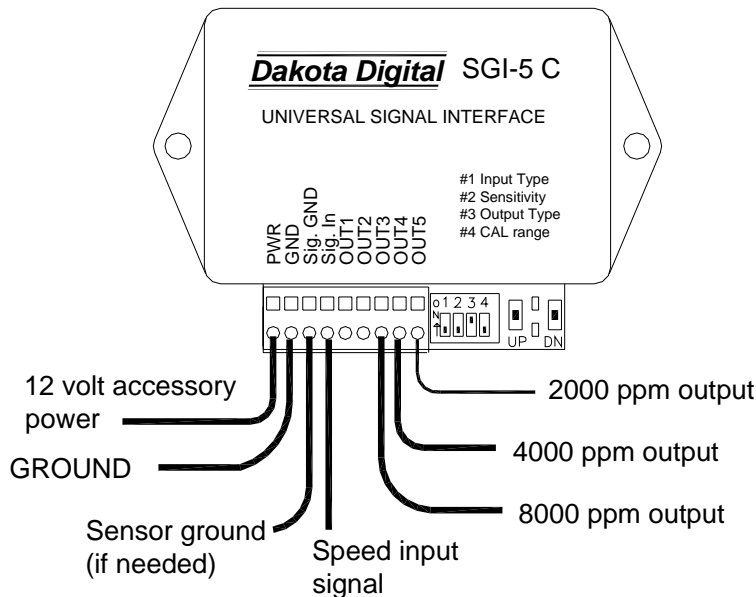

APPLICATION #4

Convert an 8000ppm signal from an aftermarket signal generator to a 4000ppm or 2000ppm to run an OEM cruise control or fuel injection computer.

Either two wire or three wire sensors can be recalibrated with this unit. Two wire sensors will typically have one wire as a ground and the other as the signal. Three wire sensors will have an additional power wire. You must first determine which wire is the signal. The signal wire will be tapped into so the SGI-5 can read it. The sensor signal wire will go to the SIG IN terminal. Connect the PWR terminal to a 12-volt accessory wire and connect the GND terminal to a good ground location. If nothing else is connected to a two wire sensor, then connect one wire to the GND terminal also. The output connections will depend on your particular application. Here are some typical examples:

OUT3, 4000ppm AC: most TPI computers and some OEM cruise controls
OUT4, 4000ppm oc: use this if OUT3 does not provide a good signal
OUT5, 2000ppm oc: most TBI computers and some OEM cruise controls

Begin with the switches as follows and then determine how far off the calibration is.

1	2	3	4
OFF	OFF	OFF	OFF

APPLICATION #5

Convert a 16000ppm signal from a Hall Effect VDO signal generator to 8000ppm, 4000ppm, or 2000ppm to run a cruise control or fuel injection computer.

The Hall Effect sensor will have three wires. The white wire is the signal. The signal wire will be tapped into so the SGI-5 can read it. The sensor signal wire will go to the SIG IN terminal. Connect the PWR terminal to a 12-volt accessory wire and connect the GND terminal to a good ground location. The output connections will depend on your particular application. Here are some typical examples:

OUT1, 8000ppm AC: most aftermarket cruise controls
OUT3, 4000ppm AC: most TPI computers and some OEM cruise controls
OUT4, 4000ppm oc: use this if OUT3 does not provide a good signal
OUT5, 2000ppm oc: most TBI computers and some OEM cruise controls

Begin with the switches as follows and then determine how far off the calibration is.

1	2	3	4
ON	ON	OFF	OFF

APPLICATION #6

Convert a 4000ppm signal from an OEM transmission speed sensor or ECM output to an 8000ppm signal for an aftermarket speedometer.

The speed sensors have a two-pin connector on the transmission or transfer case. One of the pins will be a ground and the other will be the signal. The ground pin will go the GND terminal along with the ground wire. The signal pin will go to the SIG IN terminal. It is best to twist the signal and ground wires from the sensor around each other. This helps eliminate any electrical interference. If nothing else is connected to the speed sensor it does not matter which pin is used as the ground. If you are picking up a signal coming out of the ECM there will be only one wire to the SIG IN. Connect the PWR terminal to accessory power and the GND terminal to ground. Connect OUT1 to your aftermarket electric speedometer.

Begin with the switches as follows and then determine how far off the calibration is.

1	2	3	4
ON	OFF	OFF	ON

Cal Hi represents switch #4 ON. Cal Lo represents switch #4 OFF. Tach column is with switch #4 OFF.

Coarse.	Fine.	Cal Hi	Cal Lo	tach	Coarse.	Fine.	Cal Hi	Cal Lo	tach	Coarse.	Fine.	Cal Hi	Cal Lo	tach	Coarse.	Fine.	Cal Hi	Cal Lo	tach
16	16	4.000	1.000	128	12	16	2.667	0.667	192	8	16	2.000	0.500	256	4	16	1.333	0.333	384
16	15	3.969	0.992	129	12	15	2.653	0.663	193	8	15	1.984	0.496	258	4	15	1.326	0.332	386
16	14	3.938	0.985	130	12	14	2.639	0.660	194	8	14	1.969	0.492	260	4	14	1.320	0.330	388
16	13	3.908	0.977	131	12	13	2.626	0.656	195	8	13	1.954	0.489	262	4	13	1.313	0.328	390
16	12	3.879	0.970	132	12	12	2.612	0.653	196	8	12	1.939	0.485	264	4	12	1.306	0.327	392
16	11	3.850	0.962	133	12	11	2.599	0.650	197	8	11	1.925	0.481	266	4	11	1.299	0.325	394
16	10	3.821	0.955	134	12	10	2.586	0.646	198	8	10	1.910	0.478	268	4	10	1.293	0.323	396
16	9	3.793	0.948	135	12	9	2.573	0.643	199	8	9	1.896	0.474	270	4	9	1.286	0.322	398
16	8	3.765	0.941	136	12	8	2.560	0.640	200	8	8	1.882	0.471	272	4	8	1.280	0.320	400
16	7	3.737	0.934	137	12	7	2.547	0.637	201	8	7	1.869	0.467	274	4	7	1.274	0.318	402
16	6	3.710	0.928	138	12	6	2.535	0.634	202	8	6	1.855	0.464	276	4	6	1.267	0.317	404
16	5	3.683	0.921	139	12	5	2.522	0.631	203	8	5	1.842	0.460	278	4	5	1.261	0.315	406
16	4	3.657	0.914	140	12	4	2.510	0.627	204	8	4	1.829	0.457	280	4	4	1.255	0.314	408
16	3	3.631	0.908	141	12	3	2.498	0.624	205	8	3	1.816	0.454	282	4	3	1.249	0.312	410
16	2	3.606	0.901	142	12	2	2.485	0.621	206	8	2	1.803	0.451	284	4	2	1.243	0.311	412
16	1	3.580	0.895	143	12	1	2.473	0.618	207	8	1	1.790	0.448	286	4	1	1.237	0.309	414
15	16	3.556	0.889	144	11	16	2.462	0.615	208	7	16	1.778	0.444	288	3	16	1.231	0.308	416
15	15	3.531	0.883	145	11	15	2.450	0.612	209	7	15	1.766	0.441	290	3	15	1.225	0.306	418
15	14	3.507	0.877	146	11	14	2.438	0.610	210	7	14	1.753	0.438	292	3	14	1.219	0.305	420
15	13	3.483	0.871	147	11	13	2.427	0.607	211	7	13	1.741	0.435	294	3	13	1.213	0.303	422
15	12	3.459	0.865	148	11	12	2.415	0.604	212	7	12	1.730	0.432	296	3	12	1.208	0.302	424
15	11	3.436	0.859	149	11	11	2.404	0.601	213	7	11	1.718	0.430	298	3	11	1.202	0.300	426
15	10	3.413	0.853	150	11	10	2.393	0.598	214	7	10	1.707	0.427	300	3	10	1.196	0.299	428
15	9	3.391	0.848	151	11	9	2.381	0.595	215	7	9	1.695	0.424	302	3	9	1.191	0.298	430
15	8	3.368	0.842	152	11	8	2.370	0.593	216	7	8	1.684	0.421	304	3	8	1.185	0.296	432
15	7	3.346	0.837	153	11	7	2.359	0.590	217	7	7	1.673	0.418	306	3	7	1.180	0.295	434
15	6	3.325	0.831	154	11	6	2.349	0.587	218	7	6	1.662	0.416	308	3	6	1.174	0.294	436
15	5	3.303	0.826	155	11	5	2.338	0.584	219	7	5	1.652	0.413	310	3	5	1.169	0.292	438
15	4	3.282	0.821	156	11	4	2.327	0.582	220	7	4	1.641	0.410	312	3	4	1.164	0.291	440
15	3	3.261	0.815	157	11	3	2.317	0.579	221	7	3	1.631	0.408	314	3	3	1.158	0.290	442
15	2	3.241	0.810	158	11	2	2.306	0.577	222	7	2	1.620	0.405	316	3	2	1.153	0.288	444
15	1	3.220	0.805	159	11	1	2.296	0.574	223	7	1	1.610	0.403	318	3	1	1.148	0.287	446
14	16	3.200	0.800	160	10	16	2.286	0.571	224	6	16	1.600	0.400	320	2	16	1.143	0.286	448
14	15	3.180	0.795	161	10	15	2.276	0.569	225	6	15	1.590	0.398	322	2	15	1.138	0.284	450
14	14	3.160	0.790	162	10	14	2.265	0.566	226	6	14	1.580	0.395	324	2	14	1.133	0.283	452
14	13	3.141	0.785	163	10	13	2.256	0.564	227	6	13	1.571	0.393	326	2	13	1.128	0.282	454
14	12	3.122	0.780	164	10	12	2.246	0.561	228	6	12	1.561	0.390	328	2	12	1.123	0.281	456
14	11	3.103	0.776	165	10	11	2.236	0.559	229	6	11	1.552	0.388	330	2	11	1.118	0.279	458
14	10	3.084	0.771	166	10	10	2.226	0.557	230	6	10	1.542	0.386	332	2	10	1.113	0.278	460
14	9	3.066	0.766	167	10	9	2.216	0.554	231	6	9	1.533	0.383	334	2	9	1.108	0.277	462
14	8	3.048	0.762	168	10	8	2.207	0.552	232	6	8	1.524	0.381	336	2	8	1.103	0.276	464
14	7	3.030	0.757	169	10	7	2.197	0.549	233	6	7	1.515	0.379	338	2	7	1.099	0.275	466
14	6	3.012	0.753	170	10	6	2.188	0.547	234	6	6	1.506	0.376	340	2	6	1.094	0.274	468
14	5	2.994	0.749	171	10	5	2.179	0.545	235	6	5	1.497	0.374	342	2	5	1.089	0.272	470
14	4	2.977	0.744	172	10	4	2.169	0.542	236	6	4	1.488	0.372	344	2	4	1.085	0.271	472
14	3	2.960	0.740	173	10	3	2.160	0.540	237	6	3	1.480	0.370	346	2	3	1.080	0.270	474
14	2	2.943	0.736	174	10	2	2.151	0.538	238	6	2	1.471	0.368	348	2	2	1.076	0.269	476
14	1	2.926	0.731	175	10	1	2.142	0.536	239	6	1	1.463	0.366	350	2	1	1.071	0.268	478
13	16	2.909	0.727	176	9	16	2.133	0.533	240	5	16	1.455	0.364	352	1	16	1.067	0.267	480
13	15	2.893	0.723	177	9	15	2.124	0.531	241	5	15	1.446	0.362	354	1	15	1.062	0.266	482
13	14	2.876	0.719	178	9	14	2.116	0.529	242	5	14	1.438	0.360	356	1	14	1.058	0.264	484
13	13	2.860	0.715	179	9	13	2.107	0.527	243	5	13	1.430	0.358	358	1	13	1.053	0.263	486
13	12	2.844	0.711	180	9	12	2.098	0.525	244	5	12	1.422	0.356	360	1	12	1.049	0.262	488
13	11	2.829	0.707	181	9	11	2.090	0.522	245	5	11	1.414	0.354	362	1	11	1.045	0.261	490
13	10	2.813	0.703	182	9	10	2.081	0.520	246	5	10	1.407	0.352	364	1	10	1.041	0.260	492
13	9	2.798	0.699	183	9	9	2.073	0.518	247	5	9	1.399	0.350	366	1	9	1.036	0.259	494
13	8	2.783	0.696	184	9	8	2.065	0.516	248	5	8	1.391	0.348	368	1	8	1.032	0.258	496
13	7	2.768	0.692	185	9	7	2.056	0.514	249	5	7	1.384	0.346	370	1	7	1.028	0.257	498
13	6	2.753	0.688	186	9	6	2.048	0.512	250	5	6	1.376	0.344	372	1	6	1.024	0.256	500
13	5	2.738	0.684	187	9	5	2.040	0.510	251	5	5	1.369	0.342	374	1	5	1.020	0.255	502
13	4	2.723	0.681	188	9	4	2.032	0.508	252	5	4	1.362	0.340	376	1	4	1.016	0.254	504
13	3	2.709	0.677	189	9	3	2.024	0.506	253	5	3	1.354	0.339	378	1	3	1.012	0.253	506
13	2	2.695	0.674	190	9	2	2.016	0.504	254	5	2	1.347	0.337	380	1	2	1.008	0.252	508
13	1	2.681	0.670	191	9	1	2.008	0.502	255	5	1	1.340	0.335	382	1	1	1.004	0.251	510

Trouble shooting guide

Problem	Possible Cause	Solution
Speedometer will not work. GREEN light off.	No power to SGI-5.	Check the power and ground terminals on the SGI-5. Should be 11-15 V dc.
Speedometer will not work. GREEN light on steady.	No input signal. SGI-5 set for wrong input type. Grounding interference.	Test for 1-20 volts AC at the signal in terminal with the wheels spinning. Turn switch #1 ON and #2 OFF. Make sure both the speed sensor and SGI-5 are grounded at the same point.
Speedometer will not work. GREEN light flashing.	Wrong output type.	Try switching from an oc to AC output or from an AC to oc output.
Speedometer will not read at low speeds	SGI-5 set for wrong input type. Speed signal is too low.	Turn switch #2 OFF. Check speed connections for ground problems or shorts. Test the ground connection between SGI-5 and sensor. Check for another device loading down the sensor.
Speedometer will read when the vehicle is sitting still.	Tach wire too close to speed signal wire. Signal In and OUT wires routed too close. Ground interference.	Route the speed signal and tachometer wires away from each other to avoid interference. Route the input and output wires away from each other to avoid feedback. Make sure the speed sensor and SGI-5 are grounded together.
UP switch will not work DN switch will not work	Sensitivity set incorrectly Cal range is at max value Cal range is at min value	Turn switch #2 ON. Turn switch #4 ON. Turn switch #4 OFF.
Transmission does not shift properly, or not at all	Wired improperly Incorrect application	Contact technical support

Tech Support

You can contact us with any questions you may have by phone, fax, or email.

Dakota Digital

4510 W. 61ST St. N., Sioux Falls, SD 57107
Phone: (605) 332-6513 FAX: (605) 339-4106
www.dakotadigital.com
dakotasupport@dakotadigital.com

©Copyright 2004 Dakota Digital Inc.