



## **CMD-4000 SERIES REV. A 4+ FUNCTION REMOTE CONTROL DOOR LATCH OPENER SYSTEM**

### **INTRODUCTION**

Thank you for purchasing the CMD-4000 series Remote Control Door Latch Opener System from Dakota Digital, Inc. This, along with many other products that Dakota Digital, Inc. has to offer, represents the latest in electronics technology for the street rod, classic car and truck, and any custom vehicle.

The CMD-4000 Remote Control Door Latch Opener system comes complete with receiver, two key chain transmitters, wiring harness, and emergency release switch. The CMD-4001 includes the CMD-4000 along with two PDR-1 door release actuators. The CMD-4002 includes the CMD-4000 along with three PDR-1 door release actuators. It is installed to remotely release the driver's and passenger's doors independently along with additional channels to release a trunk latch, rear door latch, operate a motor, or whatever. A safety feature disables the system when the ignition is on to avoid accidental door opening during vehicle operation. An emergency release switch can be concealed on the underside of the vehicle should the door ever be closed with the motor running and you on the outside. Pressing this button will allow reentry to the vehicle even though the remote control system is disabled.

### **INSTALLATION**

While installation of the CMD-4000 is very straightforward, paying a little attention here and planning out how the system will fit into your specific vehicle will save some time in the long run. First, determine the best mounting method for the door motors within the doors. The pull (or push) on the original door latch or newer bear claw latch should be as straight as possible. Securely mount the motor and route a connecting rod as pertains to your specific situation.

The receiver should be mounted under the dash up on the fire wall for best access to wiring. The kick panel is also another good location for the receiver.

Connect the CMD-4000 system as is shown in the wiring diagram. While the wiring diagram is self explanatory, there are several key areas to pay particular attention to. First, the 12 volt source should be able to supply up to 10 amps if standard door actuators are used or 30 amps if high power solenoids are used. It should not be connected to a feed that is shared with a high current device such as a power window, power seat, or fan. Connecting to a source shared by a device such as this may cause improper operation due to the surge current and subsequent voltage drop caused by the high current devices. The CMD-4000 should only be connected to a 12 volt battery for power and never solely to a battery charger.

### **ADDITIONAL TRANSMITTERS**

The transmitters supplied with your remote system are serial number coded for security. Each unit can "learn" up to 4 transmitters. It is also possible to program one transmitter into more than one receiver. If you have more than one vehicle with the CMD-4000 system you can program all of the transmitters into both units. Transmitters from other manufacturers, such as car alarm systems, will not work with the CMD-4000.

## WIRING HARNESS COLOR CODE.

### 10 pin connector

|             |                                 |
|-------------|---------------------------------|
| RED         | constant 12 volt battery source |
| BLACK       | chassis ground                  |
| YELLOW      | ignition key switched 12 volts  |
| VIOLET      | CHANNEL 7 relay (optional)      |
| WHITE/BLACK | CHANNEL 6 relay (optional)      |
| BLUE        | CHANNEL 5 relay (optional)      |
| BROWN       | CHANNEL 4 relay (optional)      |
| ORANGE      | CHANNEL 3 relay (optional)      |
| GRAY        | not used                        |
| GREEN       | not used                        |

### 5 spade connectors

|                          |        |   |
|--------------------------|--------|---|
| 5 <sup>th</sup> from end | VIOLET | not used                                    |
| 4 <sup>th</sup> from end | ORANGE | not used                                    |
| 3 <sup>rd</sup> from end | RED    | +12 volt battery source                     |
| 2 <sup>nd</sup> from end | BROWN  | driver's door latch actuator (CHANNEL 1)    |
| outside end              | YELLOW | passenger's door latch actuator (CHANNEL 2) |

The Brown and Yellow wires on the spade connectors are connected to internal relays and can feed 12 volts out at up to 30 amps. The orange, white/black, blue, brown, and orange wires are negative switched outputs designed to turn on external relays. These outputs can only handle 0.25 amps and must be used with a relay. Two additional relays are supplied in the kit. To use all 7 channels you will need to purchase three additional relays.

## OPERATION

Each key chain transmitter has four buttons. Each button will activate its own independent channel when pressed. Also, an additional 3 channels can be activated by pressing button 1 and one of the other three buttons at the same time.

- Button 1 activates the driver's door latch release on Channel 1. Button 2 activates the passenger's door latch release on Channel 2. These channels provide 12 volts out which can feed up to 30 amps. These outputs will remain on for as long as the button is held, so the buttons should never be held in for more than a couple of seconds at a time to avoid burning out the door actuators.
- Button 3 can activate an external relay to power a trunk latch release or other function on the Channel 3 output. Button 4 can activate an external relay on the Channel 4 output.
- Pressing buttons 1 and 2 at the same time activates an external relay on Channel 5.
- Pressing buttons 1 and 3 at the same time activates an external relay on Channel 6.
- Pressing buttons 1 and 4 at the same time activates an external relay on Channel 7 for ½ sec.

When the ignition key is "ON", the remote system outputs for channels 1, 2, 3, and 4 are disabled. The remote outputs for channels 5, 6, and 7 will operate whether the ignition is on or off. This safety feature will not allow the doors to accidentally release while the vehicle is in motion. This disables the key chain transmitters only. The "override" switches will not be disabled.

The unit will stop operating for 30 seconds if any combination of buttons 1 or 2 are pushed eight (8) times in 30 seconds. This is to prevent overheating the door actuators.

The emergency release switch provides power directly to the door release actuator. The switch bypasses the remote system, so it will operate when the system is disabled by the ignition being on.

On vehicles with suicide doors, we recommend using a mechanical sliding dead bolt lock to ensure that there is no way for the doors to open while the vehicle is going down the road.

The only wires that need to be passed to the doors are the two wires running to each door motor. This should be done using a flexible rubber tube or rubber grommet to protect the wires, or by using the optional **DAKOTA DIGITAL, INC. MAGNUM SHOOTERS**. **MAGNUM SHOOTERS** will eliminate the wires running through the door jambs entirely for the cleanest appearance possible. When these highly conductive brass contacts are mounted to the door and to the door jamb they eliminate the wires completely. If you would like to use **MAGNUM SHOOTERS** they can be ordered directly from **DAKOTA DIGITAL, INC.** by calling toll free 1-800-852-3228. Using either the flexible rubber tube, or **MAGNUM SHOOTERS**, route the remaining wires under the dash for the best location and appearance.

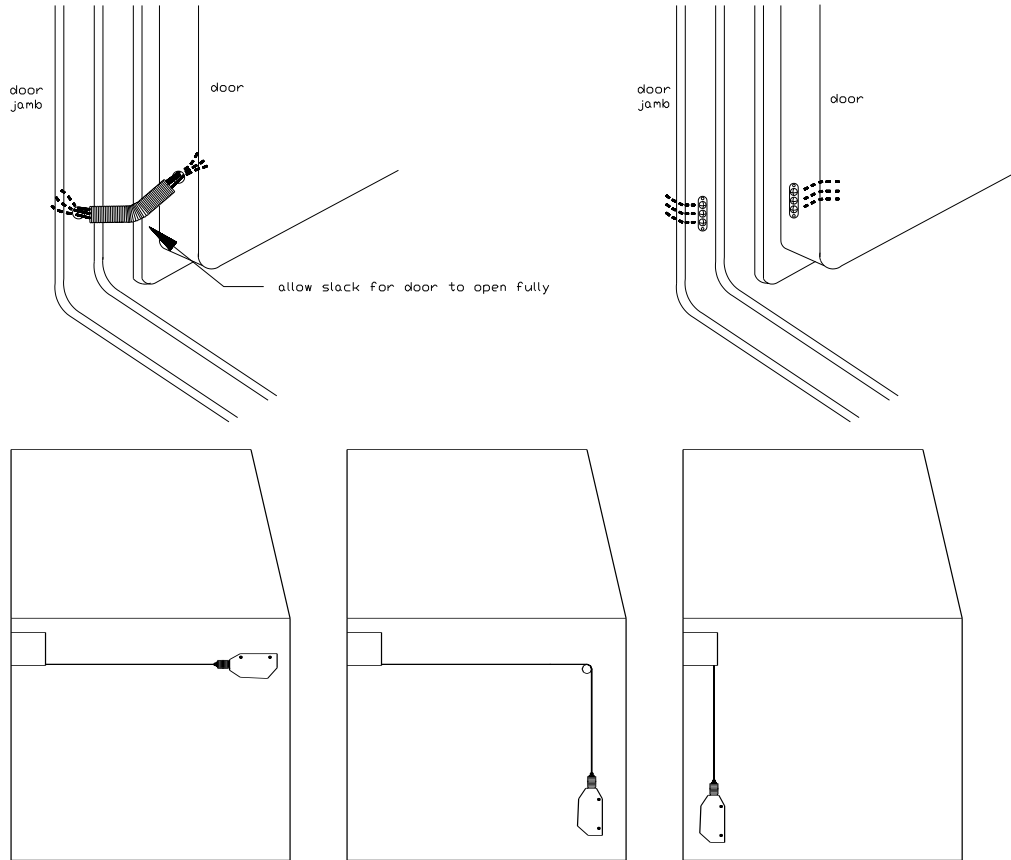

Using a rod or cable, connect the actuator to the inside or outside release lever on the latch.

Using a rod or cable, connect the actuator to the inside or outside release lever on the latch.

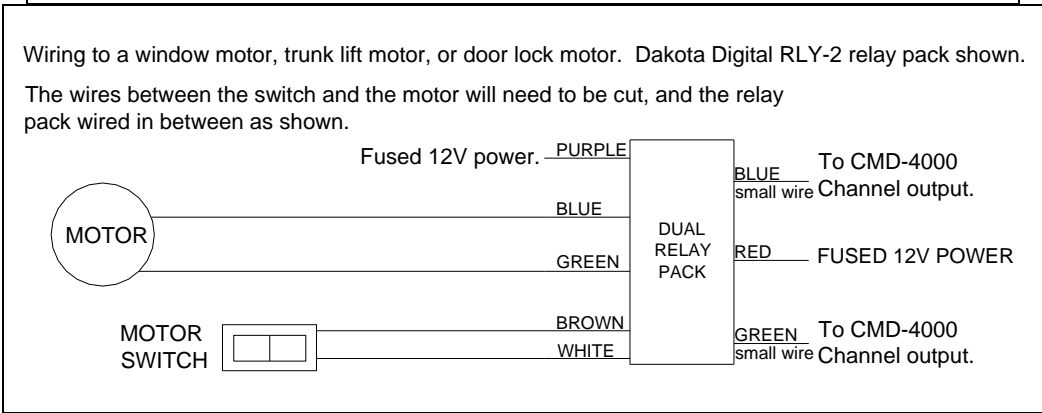
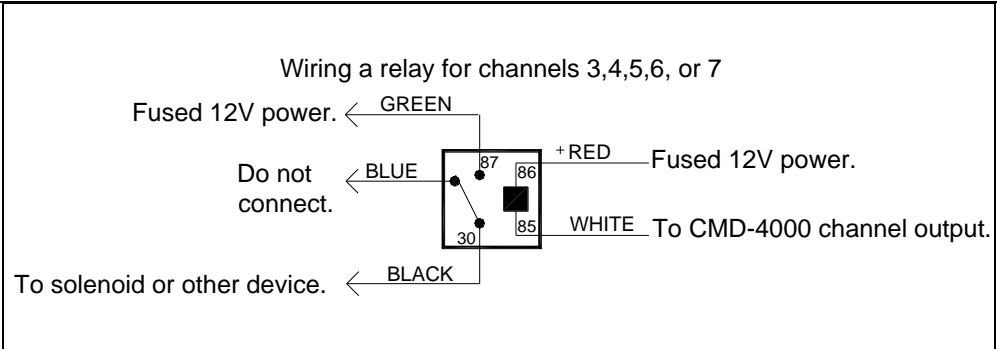
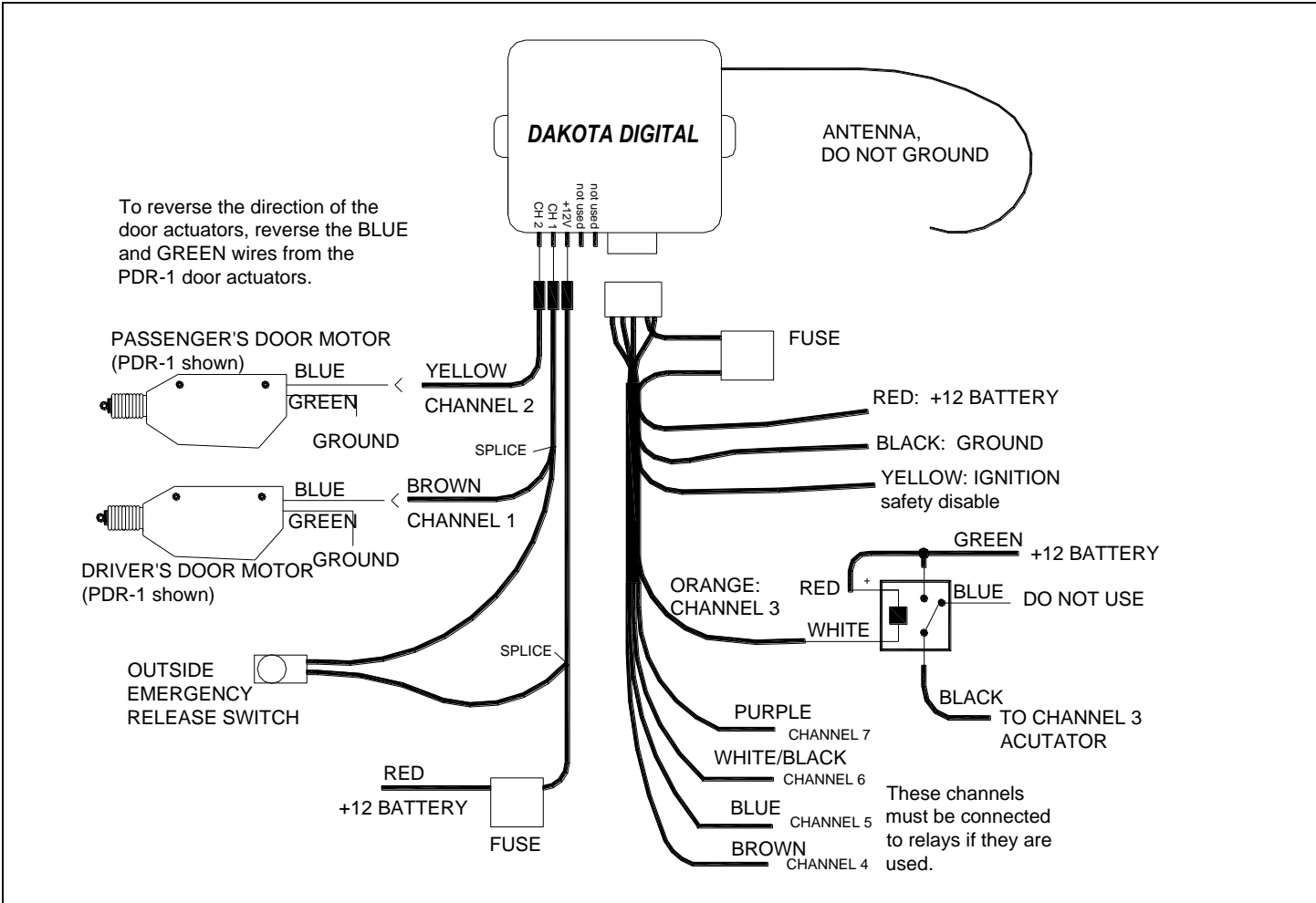

**Note:**

**REMOTES SHIPPED WITH THE CMD-4000 ARE ALREADY PRE-PROGRAMMED**

The following steps are required only when adding an additional remote, or replacing a remote.

**DIP SWITCH SETTINGS**

For optimal performance, all switches should be in the "OFF" position. If any switches are in the "ON" position damage or incorrect operation may occur to the attached components.

**TRANSMITTER PROGRAMMING**

All of the transmitters to be programmed into the system should be available. This sequence will erase any previously programmed transmitters. If a transmitter is lost or stolen, go through the programming sequence with the remaining transmitters and the lost one will be erased. The programming light (LED) is located on the side opposite the antenna, next to the programming switch.

1. Press and release the programming switch 3 times. The LED should come on and remain on steady.
2. Press button 1 on the first remote. The LED should go out and then come back on steady.
3. Press button 1 on the second remote. The LED should go out and then come back on steady.
4. Repeat this for up to 4 remotes total.
5. When all of the remotes have been programmed in, wait for the LED to go out. The system will now operate normally with all of the remotes.

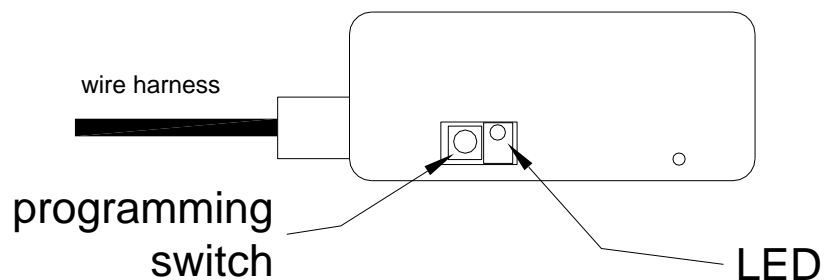

**BATTERY REPLACEMENT**

Should the transmitter function become weak or erratic, the battery in the key chain transmitter may be weak. An indication of a weak battery is that the red indicator may have a dim glow to it when either button is pressed. If this occurs, first check the system by using the second transmitter provided. If the second transmitter function properly, replace the battery in the defective transmitter by the following method:

- A. Use a small, flat screw driver or knife to pry the case apart next to the chain.
- B. Carefully separate the two case halves.
- C. Remove the battery noting the (+) and (-) position.
- D. Replace the battery with a new 12 volt type GP23A battery which is available at most electronic stores (Radio Shack, etc.).
- E. Carefully replace the top cover snap it into place.
- F. Check transmitter function.

## TROUBLE SHOOTING GUIDE

| Symptom   | Possible Problem   | Solution  |
|---|--|---|
| System will not operate doors or trunk (LED does not flash).        | Receiver is not getting power.   | Check 12 volt connection.<br>Check ground connection.<br>Check fuses.                             |
| Doors and trunk will not work. (LED flashes when button is pressed) | Ignition key is on.<br>Yellow wire has 12 volts at all times.                | Turn off ignition key.<br>Move yellow wire to a terminal that is powered only when the key is on. |
| Door latch actuators 'jump' or 'chatter'.                           | Weak or poor 12 volt connection.<br>Antenna is too close to the power wires. | Check 12 volt connection.<br>Move to new terminal point.<br>Reposition antenna or wiring harness. |
| Transmitter has very short range on all functions.                  | Transmitter battery is weak.<br>Antenna needs repositioning                  | See Battery Replacement.<br>Move antenna out away from any high current wires.                    |
| Emergency Entry button will not work.                               | Switch not hooked up correctly.  | Check power connection.<br>Check wiring connection.   |

If none of these solutions solve the problem, or the problem occurring is not listed here, please call the Dakota Digital technical assistance line at (605) 332-6513 for further assistance or email to [dakotasupport@dakotadigital.com](mailto:dakotasupport@dakotadigital.com).

## **SERVICE AND REPAIR**

DAKOTA DIGITAL offers complete service and repair of its product line. In addition, technical support is available to help you work through any questions or problems you may be having installing one of our products. Please read through the Troubleshooting Guide. There, you will find the solution to most problems.

For additional support, please visit [www.dakotadigital.com](http://www.dakotadigital.com). A “**Product Support**” link will be found at the bottom of the home page.

**Should you ever need to send the unit back for repairs, please call our technical support line, (605) 332-6513, to request a Return Merchandise Authorization number.**

- Package the product in a good quality box along with plenty of packing material.
- Ship the product by a common carrier with tracking abilities.
- Be sure to include the RMA number on the package.
- Include a complete description of the problem, with RMA number, your full name and address (street address preferred), and a telephone number where you can be reached during the day.
- Any returns for warranty work must include a copy of the dated sales receipt from your place of purchase.
- Send no money. We will contact you for payment.

### **Dakota Digital Limited Lifetime Warranty**

DAKOTA DIGITAL warrants to the ORIGINAL PURCHASER of this product that should it, under normal use and condition, be proven defective in material or workmanship for the lifetime of the original vehicle it was installed in, such defect(s) will be repaired or replaced at Dakota Digital's option.

This warranty does not cover nor extend to damage to the vehicle's systems, and does not cover diagnosis, removal or reinstallation of the product.

This Warranty does not apply to any product or part thereof which in the opinion of the Company has been damaged through alteration, improper installation, mishandling, misuse, neglect, or accident.

Dakota Digital assumes no responsibility for loss of time, vehicle use, owner inconvenience nor related expenses.

Dakota Digital will cover the return standard freight once the product has been evaluated for warranty consideration, however the incoming transportation is to be covered by the owner.

This Warranty is in lieu of all other expressed warranties or liabilities. Any implied warranties, including any implied warranty of merchantability, shall be limited to the duration of this written warranty. No person or representative is authorized to assume, for Dakota Digital, any liability other than expressed herein in connection with the sale of this product.

**⚠WARNING:** This product can expose you to chemicals including lead, which is known to the State of California to cause cancer and birth defects or other reproductive harm. For more information go to [www.P65Warnings.ca.gov](http://www.P65Warnings.ca.gov)



**4510 W. 61st St. North  
Sioux Falls, SD 57107**

[www.dakotadigital.com](http://www.dakotadigital.com)

[dakotasupport@dakotadigital.com](mailto:dakotasupport@dakotadigital.com)

Phone (605) 332-6513

Fax (605) 339-4106

© Copyright 2019 - Dakota Digital