

# Odyssey

Manufactured by **Dakota Digital**

## ODY-05-1 rev. B VOLTMETER

### Introduction:

The Odyssey gauge series from Dakota Digital, Inc. incorporates the reliability and quality of our standard gauges, along with several unique features and easy mounting. These features include:

- A warning feature that flashes the gauge readout when outside operating limits.
- User adjustable warning points.
- Microprocessor stabilized readings.
- Quick-Start feature to provide accurate readings quickly after being powered up.
- Night dimming with lens label lighting.
- High Visibility VFD display for sunlight readability.

The voltage gauge will read the voltage at the sender terminal. Your cars electrical system voltage gives you information on the current state of your alternator and battery. With the engine running and the alternator charging the voltage is usually between 13.5 and 14.5 volts. As more load is placed on the system, headlights or air conditioning, this voltage will drop. If this voltage is too low then your battery will not be recharged. If this voltage is too high then the battery will be overcharged. Overcharging can damage the battery and will shorten its life. When the engine is not running the gauge shows the current battery state. With no or few accessories running, the battery voltage will usually be somewhere between 12 volts and the charging voltage. If this voltage is too far below 12 volts then the battery either needs to be recharged or replaced.

The voltage gauge will operate in the voltage range of 8.0 – 17.0 and read correct between the voltage range of 1.0 - 18.0 volts. It has a user adjustable lower warning level and a preset upper warning. This can be set to indicate low voltage and overcharging conditions.

### Operation:

The gauge needs only the PWR and GND terminals connected to operate. When the DIM terminal has 12 volts, it will dim the display for night viewing. The SND terminal is the voltage sensing input. To read the vehicle system voltage, connect this to the PWR terminal. To read the voltage at a second battery or other remote location, connect a wire from the SND terminal to the voltage to be monitored.

### Setting the warning limit:

The low warning limit can be set to different values. The shaft sticking out of the back of the gauge is used for setting the warning limit. Any time the SND terminal is disconnected the gauge will display the warning set point. The procedure for setting the warning limit is as follows:

1. Disconnect the SND terminal.
2. Turn the key on so the gauge is powered.
3. The display will flash rapidly and display a number between 8.0 and 13.6.
4. Turn the shaft on the back of the gauge until the desired low warning is displayed. The shaft will turn  $\frac{3}{4}$  rotation from stop to stop. Do not attempt to turn it past the stops.
5. Turn the key off. Reconnect the SND terminal to the voltage source to be monitored.
6. The gauge will now operate normally when powered up again.

warning adj. pot

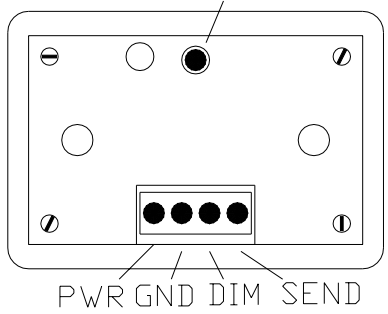

BOTTOM VIEW

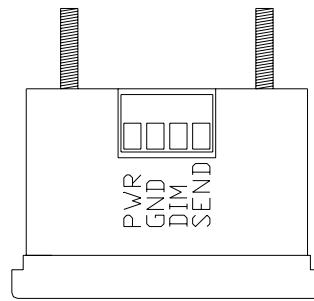

**Wiring:**

- PWR - connect to 12 volt power.  
(An accessory terminal will work for this.)
- GND - connect to a good ground point in the vehicle.
- DIM - connect to the tail light circuit.
- SEND - connect to the point where you want to monitor the voltage.

**Mounting:**

The gauge requires a rectangular cut out that is about 2 9/16" x 1 11/16". It should be inserted into the opening from the front and the U-clamp will be installed from the back. Tighten the two nuts on the U-clamp so that the gauge is secure. Figure 2 shows the required cut out for the gauge. Figure 3 shows how the gauge mounts.

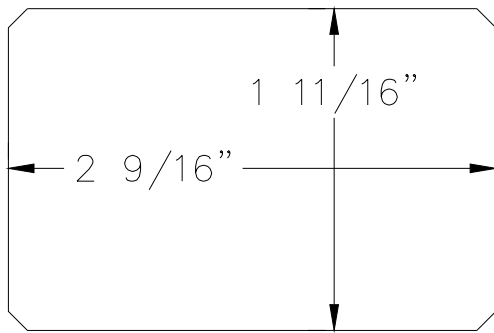

dash cutout

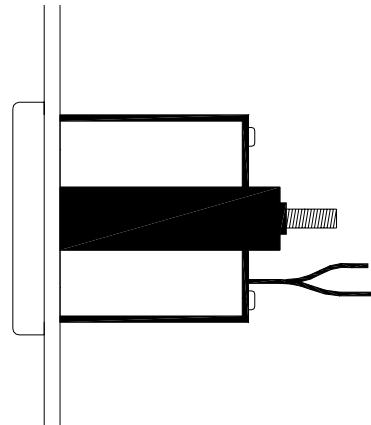

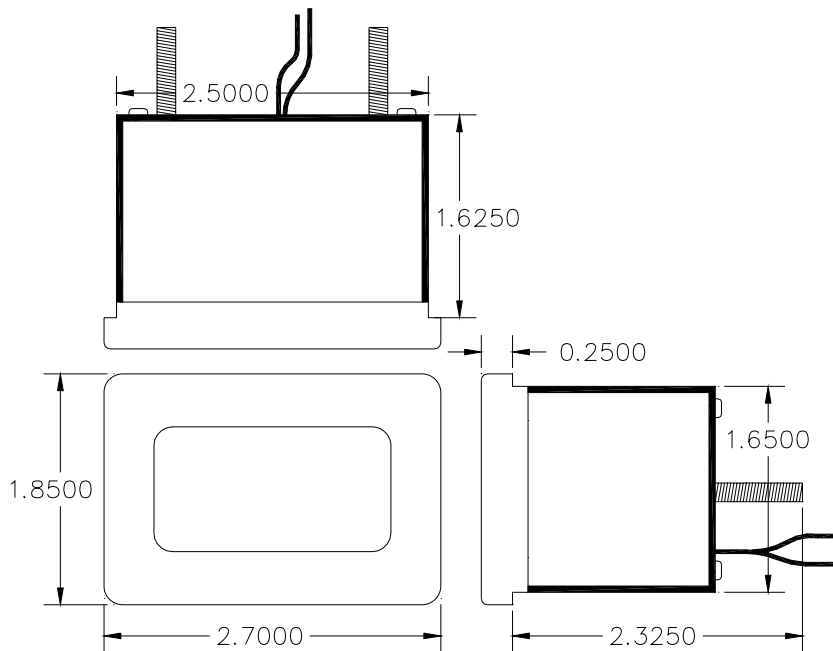

**Troubleshooting guide.**

Problem	Possible cause	Solution
Gauge will not light up	PWR terminal does not have power.	Connect to a location that has power.
	GND terminal is not getting a good ground.	Connect ground to a different location.
Gauge lights up, but does not read correctly.	Gauge is damaged.	Return gauge for repair. (see instructions)
	Loose connection on SND terminal.	Reconnect wire.
	Poor ground connection.	Move ground to different location
	Voltage or wiring problem in vehicle wiring harness.	Check wiring harness for loose or damaged wires.
	Gauge is not calibrated correctly.	Gauge must be recalibrated. (contact factory)
Gauge flashes constantly.	Warning limits are not set properly.	Reset warning limits.
	Vehicle is over charging or under charging.	Check alternator and battery.
	SND terminal is not connected.	Make sure SND terminal is connected properly.
Gauge will not dim.	DIM terminal is not connected correctly.	Check wiring connections.
Gauge remains dim at all times.	DIM terminal is getting power all of the time.	Connect blue wire to location that only has power when the headlights are on.
	Battery is very low.	Recharge or replace vehicle battery.
	Gauge is damaged.	Return gauge for repair. (contact factory)

## SERVICE AND REPAIR

DAKOTA DIGITAL offers complete service and repair of its product line. In addition, technical consultation is available to help you work through any questions or problems you may be having installing one of our units. Should you ever need to send the unit back for repairs, please package the product in a good quality box along with plenty of packing material. Ship the product by UPS or insured Parcel Post. Be sure to include a complete description of the problem, your full name and address (street address preferred), and a telephone number where you can be reached during the day. An authorization number for products being returned for repair is not needed. Do not send any money. We will bill you for the repair charges. Any returns for warranty work must include a copy of the dated invoice or bill of sale.

## Technical specifications

Minimum operating voltage	-	7 volts
Maximum operating voltage	-	18 volts
(operating at or near maximum voltage for an extended time can damage unit)		
Gauge Resolution	-	0.1 V
Gauge accuracy	-	±0.1 V
Typical current draw (@ 13.8V)	-	0.13 A

## ODYSSEY SERIES DIGITAL GAUGE LIMITED WARRANTY

DAKOTA DIGITAL (the Company) warrants to the ORIGINAL PURCHASER of this product that should it, under normal use and condition, be proven defective in material or workmanship within 24 MONTHS FROM THE DATE OF PURCHASE, such defect(s) will be repaired or replaced (at the Company's option) without charge for parts or labor directly related to repairs of the defect(s).

To obtain repair or replacement within the terms of this Warranty, the product is to be delivered with proof of warranty coverage (e.g. dated bill of sale), name, address, phone number, and specification of defects, transportation prepaid, to the factory. This Warranty is valid for the original purchaser only and may not be transferred.

This warranty does not cover nor extend to damage to vehicle electrical system. This Warranty does not apply to any product or part thereof which in the opinion of the Company has been damaged through alteration, improper installation, mishandling, misuse, neglect, or accident.

This Warranty is in lieu of all other express warranties or liabilities. ANY IMPLIED WARRANTIES, INCLUDING ANY IMPLIED WARRANTY OF MERCHANTABILITY, SHALL BE LIMITED TO THE DURATION OF THIS WRITTEN WARRANTY. ANY ACTION FOR BREACH OF ANY WARRANTY HEREUNDER INCLUDING ANY IMPLIED WARRANTY OF MERCHANTABILITY MUST BE BROUGHT WITHIN A PERIOD OF 24 MONTHS FROM DATE OF ORIGINAL PURCHASE. IN NO CASE SHALL THE COMPANY BE LIABLE FOR ANY CONSEQUENTIAL OR INCIDENTAL DAMAGES FOR BREACH OF THIS OR ANY OTHER WARRANTY, EXPRESSED OR IMPLIED, WHATSOEVER. No person or representative is authorized to assume for the Company any liability other than that expressed herein in connection with the sale of this product.

The Company does not warrant that this product cannot be compromised or circumvented. THE EXTENT OF THE COMPANY'S LIABILITY UNDER THIS WARRANTY IS LIMITED TO THE REPAIR OR REPLACEMENT PROVIDED ABOVE AND, IN NO EVENT, SHALL THE COMPANY'S LIABILITY EXCEED THE PURCHASE PRICE PAID TO THE PURCHASER FOR THE PRODUCT.

Some states do not allow limitations on how long an implied warranty lasts or the exclusion or limitation if incidental or consequential damage so the above limitations or exclusions may not apply to you. This warranty gives you specific legal rights and you may also have other rights which vary from state to state.

# ***Dakota Digital***

4510 W. 61ST St. N., Sioux Falls, SD 57107  
Phone: (605) 332-6513 FAX: (605) 339-4106  
[www.dakotadigital.com](http://www.dakotadigital.com)  
[dakotasupport@dakotadigital.com](mailto:dakotasupport@dakotadigital.com)