

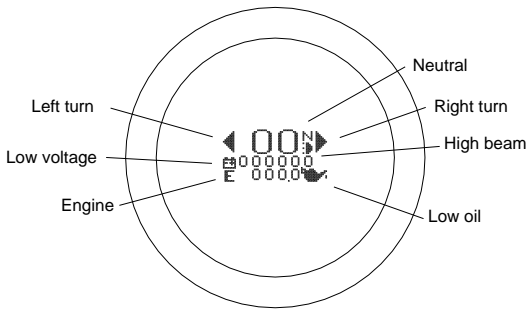

MODEL ODYR/SLX 01-5

MINIATURE SPEEDOMETER/TACHOMETER INFORMATION SYSTEM

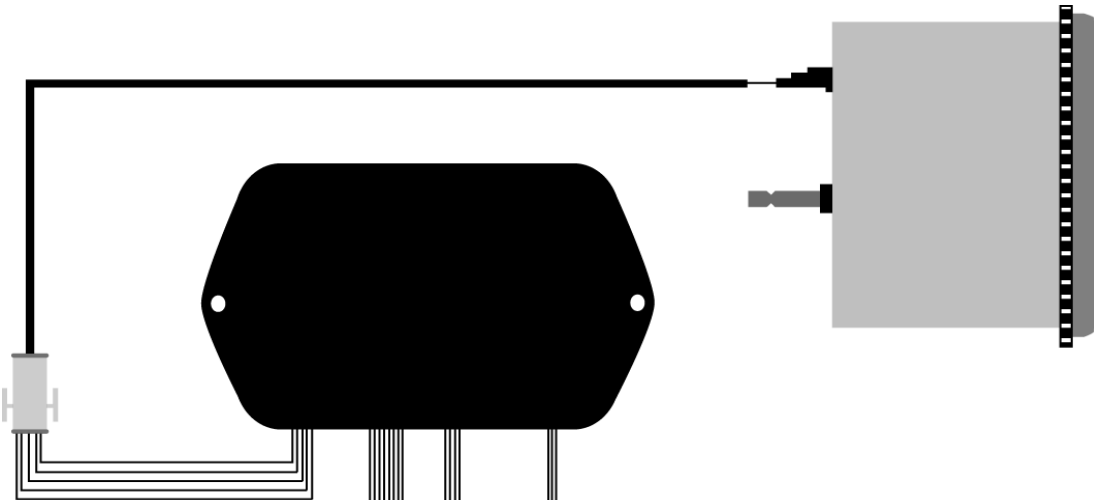

ODYR/SLX-01-5*	Function
(16g) WHITE	VSS signal
(16g) RED	VSS power
(16g) BLACK	VSS ground
RED	+12 volt power with key on
BLACK	ground (connect directly to battery negative)
GREY	oil warning indicator
YELLOW	tachometer signal
PURPLE	high beam indicator
ORANGE	left turn indicator
GREEN	right turn indicator
WHITE/BLUE	for optional remote mount function switch
BROWN	night dimming
BLUE	neutral indicator
WHITE	output speed signal
WHITE/RED	"ENGINE" indicator

*Shown below are the 4 available display screens,
and the indicators available in each.*

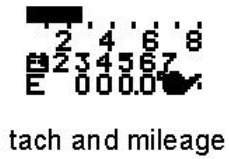

Please read this before beginning installation or wiring.

POWER

Connect the red wire from the main harness to accessory power from the ignition switch. In addition to powering the display system, this is also where the low voltage detection circuit monitors the electrical system voltage.

A good quality, solid state ignition switch should be used. The contacts on a mechanical “bar” switch can bounce due to the vibration and cause the system to momentarily lose power and reset itself.

Never connect this to a battery charger alone. It needs to have a 12 volt battery connected to it. Battery chargers have an unregulated voltage output that will cause the system to not operate properly.

GROUND

The black wire is the main ground for display system. This should be connected directly to the negative cable on the battery. Connecting to a tank or frame ground can cause a weak or intermittent ground connection. A poor ground connection can cause improper or erratic operation.

NEUTRAL, TURN SIGNAL & HIGH BEAM INDICATORS

The right turn, left turn, and high beam indicators are activated by 12 volts at their respective hook-up wires.

The right turn signal wire is green, the left turn signal wire is orange, and the high beam wire is purple. These can be connected to the same wires that the indicator lights are connected to. The display system wire colors may not match the wire colors in your electrical wire harness.

The neutral indicator is activated when the blue wire is grounded. Connect this wire to the neutral switch or to the negative side of the neutral indicator light. When the indicator is activated, an N will be lit up to the right of the speedometer.

TRIP RESET & FUNCTION SWITCH

The push button switch is found on the front face of the display. To reset the trip mileage, press and hold the switch in. Pressing and releasing the switch will change between the 4 different display screens. Pressing the switch while turning power on will enter the setup menus.

NIGHT DIMMING

Your display system has a dimming feature that dims the display intensity. Normally the system is at full brightness for daytime viewing. When the brown wire has 12 volts the display intensity will be reduced. A toggle or on/off push button switch can be connected to this wire if this feature is desired. To have the system at full brightness all of the time, leave the brown wire disconnected.

MOUNTING

The gauge requires a round hole 2-1/16” in diameter. It should be inserted into the opening from the front and the U-clamp will be installed from the back. Tighten the two nuts on the U-clamp so that the gauge is secure. Gauge depth to the back of the case is 1”. Gauge depth including the mounting studs is 1-7/8”. The controller can be mounted under the dash.

WIRING

In order to ensure that there are no problems with voltage drops causing the system to shut down, a heavy duty ignition switch is recommended, as well as proper engine grounding. The engine should have heavy braided cables to the frame, firewall, and battery.

Speedometer connection varies depending on the year and model of the vehicle. Using different speed adapter kits the speedometer can read a speedometer cable, a stock electric transmission speed sensor, or an aftermarket gear-tooth sensor, all using the three pin connector on the controller for the input. A complete description of the hookup for each wire is discussed in the various sections of this installation manual. Please consult a vehicle wiring diagram for location of necessary signal wires.

SPEEDOMETER SET-UP

Failure to calibrate the speedometer may cause your odometer mileage to increase very rapidly.

The speed input connector plugs into the speed sensor to tell how fast you are traveling. On cable driven applications, the external sensor connects to the speedometer cable and provides the electric signal. The cable driven sensor has a 5/8” coarse thread fitting and speedometer cable to fit GM transmissions. Other transmission adapters are available upon request.

With transmissions having the built-in electric sensor, a three-wire harness adapter connects the transmission speed sensor to the speedometer. This system will also accept most after-market inductive, Hall-effect, or ground switch sensors. The color code for the three wire harness is as follows: red-sensor power, white-sensor signal, black-sensor ground.

The speedometer is fully adjustable and calibration is discussed below.

SPEEDOMETER CALIBRATION

The speedometer calibration is done using the function (trip) switch. The speedometer can be calibrated two different ways. The first method is to place the unit in auto-cal mode and drive exactly one mile (one km for metric). The second method is to place the unit in adjust mode and the speed reading can be moved up or down while driving.

The speedometer will provide a reading before it is calibrated, but it may not be accurate. If the speedometer will only show 00, then it is probably not getting a speed signal. Check all of the wiring and mechanical connections carefully. If you are using a stock electric transmission sensor, remove it and check for metal filings on its magnetic end. If you are using a cable-driven sensor, make sure the cable and sensor are turning. If you are using a gear-tooth or bolt-head sensor, check the spacing to the steel target (these sensors will not read aluminum or stainless steel targets).

METHOD 1, AUTOCAL

1. Make sure the key is off so the gauge is not powered.
2. Press and hold the function switch.
3. Turn the key on. With the switch still held, start the vehicle. The display will show "DISPLAY" ". . .".
4. Release the function switch. The display will switch between "AUTO" (auto cal), "AdJ" (adjust), "CYL", "SET", "BAR", and "VOLT". The odometer will show "SELECT"
5. When "AUTO" is displayed press the function switch. This will place the unit in auto calibration mode.
6. Release the function switch. The odometer display will show all zeroes.
7. Drive exactly one mile (or 1km). The odometer will show the number of signal pulses received from the speed sensor and the trip display should still show "AUTO". The speedometer will not tell you when you have reached a mile; you need to have a mile marked out on the road.
8. Press and release the function switch. The calibration value will be calculated and stored. The gauge will now restart in normal mode with the new speed calibration.

METHOD 2, ADJUST SPEED

1. Make sure the key is off so the gauge is not powered.
2. Press and hold the function switch.
3. Turn the key on. With the switch still held, start the vehicle. The display will show "DISPLAY" ". . .".
4. Release the function switch. The display will switch between "AUTO" (auto cal), "AdJ" (adjust), "CYL", "SET", "BAR", and "VOLT". The odometer will show "SELECT"
5. When "AdJ" is displayed press the function switch. This will place the unit in calibration adjustment mode.
6. Release the function switch. The display shows the speed and the odometer will show "AdJUST"
7. Drive at a known speed. Following another vehicle that is driving at a constant, known speed can do this.
8. Press the function switch. The speed reading will begin increasing until the function switch is released. The next time the function switch is pressed, the speed reading will begin decreasing until it is released.
9. Once the speedometer is reading correct release the function switch. The new calibration will be saved if no adjustments are made for 7-10 seconds.

TACHOMETER SET-UP

The tachometer is used by connecting the yellow wire from the main harness to the negative side of the coil or to an ignition module tach output. The tachometer is adjustable for 1 – 15 cylinder settings. The 1 cylinder setting is used for single-fire ignition systems without a buffered tach output.

The following instructions are used to set the tachometer calibration:

1. Make sure the key is off so the gauge is not powered.
2. Press and hold the function switch.
3. Turn the key on so the gauge is powered. The display will show “DISPLAY” “..”.
4. Release the function switch. The display will switch between “AUTO”, “AdJ”, “CYL” (cylinder select), “SET” (shift bar), “BAR” (bar range), and “VOLT”. The odometer will show “SELECT”
5. When “CYL” is displayed press the function switch. This will place the unit in the tach calibration mode.
6. Release the function switch. The display will switch between “1 C”, “2 C”, ..., “15 C”.
7. When the desired setting is displayed press the function switch. The display will show “TACH”.
8. Release the function switch. The system will now start up normally with the new setting.

TACHOMETER RED LINE/SHIFT INDICATOR

A single bar will light up to indicate a shift point or red line. The rpm where the bar lights up is user selectable and can be turned off completely if desired. The bar is factory set to about 6000 rpm.

The following instructions are used to set the tachometer warning bar:

1. Make sure the key is off so the gauge is not powered.
2. Press and hold the function switch.
3. Turn the key on so the gauge is powered. The display will show “DISPLAY” “..”.
4. Release the function switch. The display will switch between “AUTO”, “AdJ”, “CYL” (cylinder select), “SET” (shift bar), “BAR” (bar range), and “VOLT”. The odometer will show “SELECT”
5. When “SET” is displayed press the function switch. This will place the unit in the shift/red line set mode.
6. Release the function switch. The bar display will start at 2 and begin moving up. After it reaches the top it will go out and then start back at 2.
7. When the desired rpm setting is displayed press the function switch. To disable this feature, press the function switch while the bar is not displayed. The display will show “TACH” once the new setting is stored. Release the function switch. The system will now start up normally with the new setting.

TACHOMETER BAR RANGE

The tachometer bar can be set to 0-5000, 0-8000, or 0-16,000 rpm full scale range. The bar is factory set to 8000 rpm full scale.

The following instructions are used to set the tachometer bar range:

8. Make sure the key is off so the gauge is not powered.
9. Press and hold the function switch.
10. Turn the key on so the gauge is powered. The display will show “DISPLAY” “..”.
11. Release the function switch. The display will switch between “AUTO”, “AdJ”, “CYL” (cylinder select), “SET” (shift bar), “BAR” (bar range), and “VOLT”. The odometer will show “SELECT”
12. When “BAR” is displayed press the function switch. This will place the unit in the bar range set mode.
13. Release the function switch. The bar display will show the 5000 scale, the 8000 scale, then the 16000 scale.
14. When the desired rpm bar scale is displayed press the function switch. The display will show “TACH” once the new setting is stored.

Release the function switch. The system will now start up normally with the new setting.

LOW OIL PRESSURE, LOW VOLTAGE, AND ENGINE INDICATORS

The low oil pressure warning is activated when the gray wire is grounded. Connect this wire to the oil pressure switch or the negative side of the oil warning light. The low voltage warning is activated when the voltage at the red power wire drops below 11.5 volts and there is a tachometer signal or below 10.5 volts when there is no tachometer signal. The “ENGINE” indicator is activated when the white/red wire is grounded. Connect this to the ECM or ignition module black/yellow wire or leave it open on earlier systems. If one of these warnings become active while the engine is running and the speed/tach display is selected, the display will automatically switch so that the warning indicator is visible. The function switch can be used to go back to the previous display screen.

Troubleshooting guide

Problem

Gauge will not light up

Possible cause

Red wire does not have power.

Black wire is not getting a good ground.

Display is not connected to the controller.

Gauge or controller is damaged. Return for repair. (see instructions)

Speed calibration is invalid

Tach calibration is invalid

Controller is damaged.

Speed harness is not connected properly to speedometer. Check 3 pin connector on the bottom of the speedometer.

Speed harness is not connected properly to sensor. Check connection from speed harness to the speed sensor.

Speed sensor not grounded properly. Move ground to different location, preferably close to speedometer ground.

Speed sensor is not being turned by the cable. Check cable connection at both ends. Sensor can be tested by spinning the cable with a drill.

Sensor is not sending a speed signal. See speed sensor voltage checks listed below.

Gauge is not calibrated. Gauge must be recalibrated (see instructions).

Speed sensor wire is loose or broken. Check all wire connections and inspect wire for breaks.

Cable is loose or broken. Check cable between sensor and transmission.

Poor ground connection. Check ground connection on speedometer and sensor.

Gauge is not calibrated correctly. Gauge must be calibrated (see instructions).

Gauge is not calibrated correctly. Gauge must be calibrated using "auto cal" (see instructions).

Yellow wire is not connected properly. Check connection from yellow wire to tach signal wire.

Ignition system not grounded properly. Check engine and ignition system grounds.

Gauge is not grounded properly. Check gauge and engine grounds.

Gauge is not calibrated. Gauge must be recalibrated (see instructions).

Tach signal wire is loose or broken. Check all wire connections and inspect wire for breaks.

Poor ground connection. Check ground connection on tachometer and engine.

Gauge is not calibrated correctly. Gauge must be calibrated (see instructions).

Brown wire is getting power all of the time. Connect brown wire to location that can be turned off during the day.

Loose or incorrect connection to indicator wire. Check that the appropriate indicator wire has about 0 volts when the indicator should be off and about 12 volts when the indicator should be on.

Solution

Connect to a location that has power.

Connect ground to a different location.

Check cable between display and controller.

Gauge must be recalibrated (see instructions).

Reset cylinder selection (see instructions).

Return controller for repair. (see instructions)

Check 3 pin connector on the bottom of the speedometer.

Check connection from speed harness to the speed sensor.

Move ground to different location, preferably close to speedometer ground.

Check cable connection at both ends. Sensor can be tested by spinning the cable with a drill.

See speed sensor voltage checks listed below.

Gauge must be recalibrated (see instructions).

Check all wire connections and inspect wire for breaks.

Check cable between sensor and transmission.

Check ground connection on speedometer and sensor.

Gauge must be calibrated (see instructions).

Gauge must be calibrated using "auto cal" (see instructions).

Check connection from yellow wire to tach signal wire.

Check engine and ignition system grounds.

Check gauge and engine grounds.

Gauge must be recalibrated (see instructions).

Check all wire connections and inspect wire for breaks.

Check ground connection on tachometer and engine.

Gauge must be calibrated (see instructions).

Connect brown wire to location that can be turned off during the day.

Check that the appropriate indicator wire has about 0 volts when the indicator should be off and about 12 volts when the indicator should be on.

Gauge lights up, but displays "ERROR" "SPD"

Gauge lights up, but displays "ERROR" "TACH"

Gauge lights up, but displays just "ERROR" only

Gauge lights up, but speed will only show zero.

Speed reading is erratic or jumps around.

Speed reading is incorrect.

Speedometer reads "199" while driving.

Gauge lights up, but tach will only show zero.

Tach reading is erratic or jumps around.

Tach reading is incorrect.

Gauge remains dim at all times.

High beam, Left turn, or Right turn indicator does not work.

Troubleshooting guide continued

Problem	Possible cause	Solution
Neutral, low oil, or engine indicator does not work.	Loose or incorrect connection to indicator wire.	Check that the appropriate indicator wire has about 12 volts when the indicator should be off and about 0 volts when the indicator should be on.
Turn signals do not cancel automatically.	Output speed signal to stock cancel is loose or not connected properly.	Check the connections on the solid white wire coming from the gauge.
	Speedometer is not calibrated.	Calibrate the speedometer.
	Speed sensor is not working.	If the speedometer always shows zero, check speed sensor voltages.
	Turn signal cancel module is not working.	Test turn signal module according to the vehicle's service manual.

Speed sensor voltage checks. All checks should be made with the sensor connected to the gauge and the key on. Checks should be done with a volt meter and not a test light.

3-wire sensor: Red wire should have 9-11 volts dc, slightly less than battery voltage.

Black wire should show ground, 0 volts dc at all times.

White wire should vary between 0 and 5 volts dc as the gear teeth pass by the sensor.

2-wire sensor: Measure the voltage between the two sensor wires. With the wheel spinning the voltage should be about 1-10 volts ac (make sure the meter is set to AC volts and not DC volts for this check).

SERVICE AND REPAIR

DAKOTA DIGITAL offers complete service and repair of its product line. In addition, technical consultation is available to help you work through any questions or problems you may be having installing one of our products. Please read through the Troubleshooting Guide. There, you will find the solution to most problems.

Should you ever need to send the unit back for repairs, please call our technical support line, (605) 332-6513, to request a Return Merchandise Authorization number. Package the product in a good quality box along with plenty of packing material. Ship the product by UPS or insured Parcel Post. Be sure to include the RMA number on the package, and include a complete description of the problem with RMA number, your full name and address (street address preferred), and a telephone number where you can be reached during the day. Any returns for warranty work must include a copy of the dated sales receipt from your place of purchase. Send no money. We will bill you after repair.

Dakota Digital 24 Month Warranty

DAKOTA DIGITAL warrants to the ORIGINAL PURCHASER of this product that should it, under normal use and condition, be proven defective in material or workmanship within 24 MONTHS FROM THE DATE OF PURCHASE, such defect(s) will be repaired or replaced at Dakota Digital's option.

This warranty does not cover nor extend to damage to the vehicle's systems, and does not cover removal or reinstallation of the product. This Warranty does not apply to any product or part thereof which in the opinion of the Company has been damaged through alteration, improper installation, mishandling, misuse, neglect, or accident.

This Warranty is in lieu of all other expressed warranties or liabilities. Any implied warranties, including any implied warranty of merchantability, shall be limited to the duration of this written warranty. Any action for breach of any warranty hereunder, including any implied warranty of merchantability, must be brought within a period of 24 months from date of original purchase. No person or representative is authorized to assume, for Dakota Digital, any liability other than expressed herein in connection with the sale of this product.

⚠WARNING: This product can expose you to chemicals including lead, which is known to the State of California to cause cancer and birth defects or other reproductive harm. For more information go to www.P65Warnings.ca.gov



4510 W. 61st St. North
Sioux Falls, SD 57107
www.dakotadigital.com

dakotasupport@dakotadigital.com Copyright 2011 - Dakota Digital, Inc.

Phone (605) 332-6513
Fax (605) 339-4106