

Table of Contents

Parts List	Page 2
Initial Install and Wiring	Page 4
Connectors and Pin Outs	Page 5
Step By Step Connections	Page 7
Setup Instructions	Page 16
EFI System Setup	Page 21
Using the Dakota Digital App	Page 23
Applying Software Updates	Page 26
Trouble Shooting	Page 27
Operating Instructions	Page 30
Specifications	Page 31
Safety Procedures	Page 32
Service / Warranty	Page 34

PARTS LIST

The base kit includes the standard parts:

Item	Quantity	Description	Part Number
1	1	Cruise Control Module	VCM-100 (base part no.)
2	1	OBDII DLC Harness	130063
3	1	Pedal Crossover Harness	394309-06

Two pedal harnesses are available, depending on if one needs a GM style or Ford/Mopar style. These choices are dictated by the kit number ordered.

Part	Style	Kit Number
130077 & 130078	GM GT150 Pedal Harness & GM MX64 Pedal Harness	VCM-101
130078	Ford / Mopar Pedal Harness	VCM-105

Three cruise handles are offered: two column mount models and a dash mount version. The column models use a different interface harness than the dash mount model. The appropriate harness will be supplied with the handle chosen at purchase time.

Part	Style	Mounting
HND-1	Cut-off style	Requires cutting off original plastic of turn signal
HND-2	Dash Mount	Requires three holes drilled into dash or console
HND-3	<1980 GM turn signal replacement	Replaces older GM turn signal with screw

The handles do not require a special harness. They are designed with wires to be attached to the appropriate screw terminal on the VCM. With no connector needed, it is much easier to feed the wires through the steering column to the VCM. See the wiring diagrams for proper connections to the cruise handles on page [12].

To receive speed and tach data from aftermarket EFI systems, adapter harnesses are available for the supported EFI systems:

Harness P/N	EFI Manufacturer
394241	Holley (with speed)
394238	AEM
394252	MegaSquirt
394270	Haltech
394287	FiTech
394304	Aces

Pedals vary in build and operation. A variety of pedal harnesses are available for different OEM pedals, GM, Ford and Mopar. The VCM is capable of learning at rest and depressed pedal voltages. The default pedal voltages are set up to work with GM pedals, but we recommended that you learn the pedal voltages at installation time before trying to run the cruise control as improper pedal voltages can cause vehicles to go into limp mode.

Default configuration: The VCM is set at the factory as a drive by wire configuration. It is set to use the OBDII port for speed data, and the tach and clutch inputs are disabled. It defaults to using the Dakota Digital HND-2 switch. If a factory reset is performed, it will default back to this configuration.

INITIAL INSTALL AND WIRING

1. Mounting – the VCM-100 must be mounted *inside the vehicle* and NOT in the engine bay.
2. Determine if you will be using DBW (drive by wire) or DBC (drive by cable). DBC is used when you have a mechanical linkage to your throttle body and have the secondary cable module. Drive by wire uses electrical connections to control the throttle.
3. Decide which connections are required for your application. For all applications, the following connections are required; IGNITION PWR, GND, BRAKE SW+, BRAKE SW. You will also need a Speed input and a set of Cruise Switches.

The speed input can be data from OBDII, CAN bus or from a VSS (vehicle speed sensor) signal. The speed source you choose will determine if you connect to the OBDII CABLE input or to the SPEED signal input.

The cruise switches may be one of the switches available for purchase from Dakota Digital or they can be an OEM switch. The type of switch you choose to use will determine which of the switch inputs get used. Refer to HND-1 or HND-3, HND-2 and OEM Handles sections in STEP BY STEP CONNECTIONS to determine what to connect.

Optional signals are listed below with a description of what features they provide. When not using these inputs, they can be left unconnected.

Tach: The tach information can be from the OBDII, CAN bus or a signal. The tach is used to prevent an over rev situation, mainly with manual transmissions.

Clutch +: This signal is used to disengage the cruise control if the clutch is depressed while it is operating. The switch could be a stock clutch switch that is either a Normal Open or Normally closed. Pressing the clutch the switch could either send 12 volts, or take away the 12 volts that was there. This is user selectable in the app.

Clutch -: This signal is used to disengage the cruise control if the clutch is depressed while it is operating. The switch could be a stock clutch switch that is either a Normal Open or Normally closed. Pressing the clutch the switch could either send ground, or take away the ground that was there. This is user selectable in the app.

Indicator: This is an output which produces a ground output to operate the cruise indicator on a Dakota Digital VFD3, VHX, HDX, RTX or Grafix dash system. Connect a wire from the VCM “INDICATOR” to “CRUISE” on the control box. The output could also drive the ground side of an LED light, (not an incandescent bulb).

4. Next setup the VCM to operate with the signals you have connected. Setup of the VCM can be done using the setup switch and seven segment display or through the Dakota Digital app. Dakota Digital recommends using the app as some of the more advanced features can't be configured without it. To begin setup the VCM needs to be put into setup mode. This is done by pressing and holding the setup switch on the side of the module then applying power. Additional instructions for using the setup switch and display to do setup are in the “Setup Menu” section. Instructions for using the app are in the “Using the Dakota Digital App” section.

Note: The system defaults to the Dakota Digital HND-2 control switch. If a different switch/handle is attached without changing the switch type in the setup menu, a blinking *E I* error code may show on the display. This indicates the state of the control switches was not correct on power up, and is done to prevent the cruise from engaging unintentionally. Please set the switch type to the correct setting for your switch.

CONNECTORS AND PIN OUTS

The VCM-100 has 3 connectors and 15 screw terminals. OBDII CABLE connector is for the OBDII/CAN bus cable, PEDAL CABLE connector is for the pedal harness and DBC CABLE connector is the interface to the mechanical cable drive module. The terminal names and descriptions are listed in the table below. Refer to the picture for location, then refer to the setup instructions for proper connection for your application.

Terminal Name	Input/Output	Description
SW GND	In/Out	Ground connection for the cruise control switch
SET/COAST	In	Set/Coast switch input, for use with N.O. or N.C. momentary switch
RES/ACCEL	In	Resume/Accel switch input, for use with N.O. or N.C. momentary switch
ON/OFF	In	On/Off switch input, for use with N.O. or N.C. switch
RESISTIVE	In	Input for resistive cruise control switches
SW +12V	Out	+12V connection for cruise control switch
TACH	In	Optional tach input. Used to limit max RPM for cruise module operation
BRK SW -	In	Required input. Connection to brake switch output to tail lights
BRK SW +	In	Required input. Connects to hot side of the brake switch.
SPEED	In	Speed input when not using CAN or OBDII. Connects to speed sensor or speed signal.
CLUTCH -	In	Optional input, connects to clutch switch that connects to ground
CLUTCH +	In	Optional input, connects to clutch switch that connects to +12V
INDICATOR	Out	Output to drive cruise control indicator. Drives to ground to turn on indicator.
IGNITION PWR	In	Connection to switched +12V power. Requires approximately 5A for mechanical throttle cruise module.
GROUND	In	Connection to chassis ground

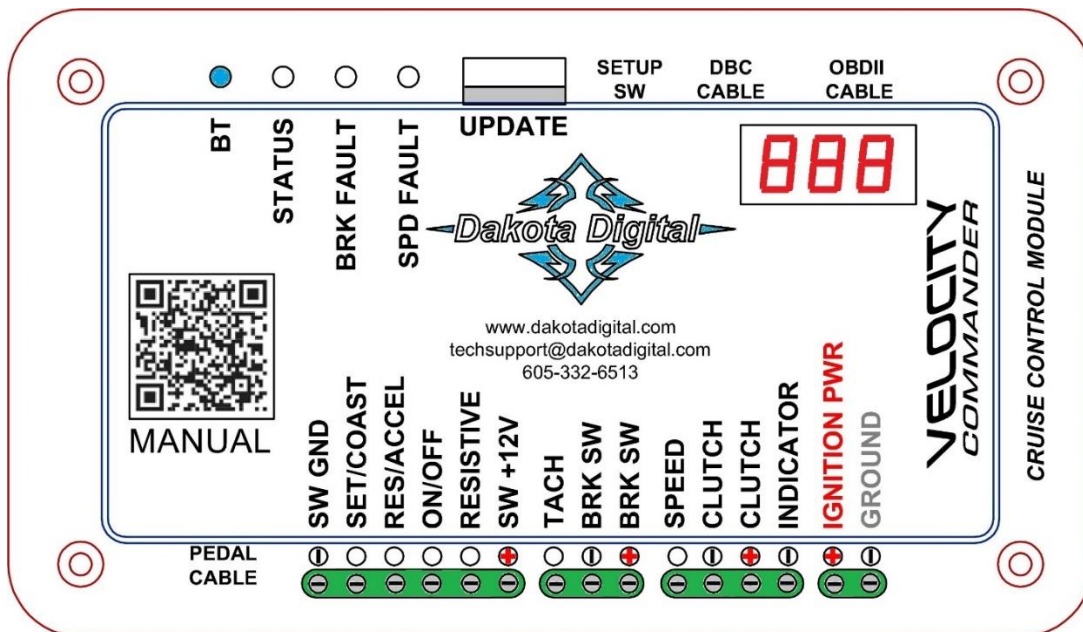

The setup switch on the side may be used to put the VCM into setup mode. Most setup can be done using the switch and seven segment display. All options can be setup using the Dakota Digital app for phones and tablets. The app makes setup much easier. Search for Dakota Digital in the Apple Store or in Google Play.



The module also has multiple status indicators. They are listed in the table below with a brief description. More in depth descriptions are provided in the troubleshooting section.



Name	Description
BT	This indicator shows the status of the built in Bluetooth module
STATUS	Indicates the status of the VCM, On, Operating and Fault indications
BRK FAULT	This indicator will turn on if the “Brake –” connection is not pulled to ground
SPD FAULT	This indicator will turn on in the absence of a speed input signal

The UPDATE (USB) port can be used to do field updates to software. Updates may include bug fixes or new features. This will require downloading a new software file onto a USB thumb drive.

Update files can be downloaded from the VCM product page from www.dakotadigital.com under the “Download” tab.

See the applying software updates section for more detailed instructions.

STEP BY STEP CONNECTIONS

Connecting Power

The "IGNITION PWR" input should be connected to switched power. Ideally this would come from a fused source. If using the mechanical Drive by Cable module for mechanical linkage applications, this source will need to be fused at a minimum of 5 Amps. The "GROUND" input should be connected to a good chassis ground.

Note for drive by wire applications: In some instances, the ground for the pedal may not be at the same potential as the chassis ground. This may cause the vehicle to go into limp mode when the cruise is engaged. In these cases, we recommend adding an additional ground wire from the Ground terminal on the VCM control box to the pedal ground. If you are unsure, we recommend making this extra ground connection.

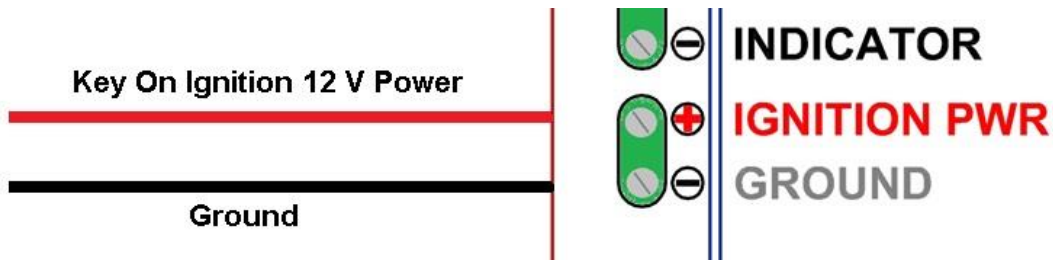

Cruise Indicator

Cruise Indicator:

The "INDICATOR" output produces a negative trigger to operate the cruise indicator on a Dakota Digital VFD3, VHX, HDX, RTX or Grafix dash system. The "INDICATOR" out will connect to the "CRUISE" terminal on these control boxes.

The "INDICATOR" out could also operate the ground side of a LED lamp.



Connecting OBDII cable

If using OBDII or Custom CAN data for the VCM you will need this cable connected. If not using OBDII or CAN data this can be left unconnected. The OBDII harness connects direct to the OBDII diagnostic plug. The OBDII harness will need to be removed from the ALDL port, if engine diagnostics needs to be performed with a scan tool.

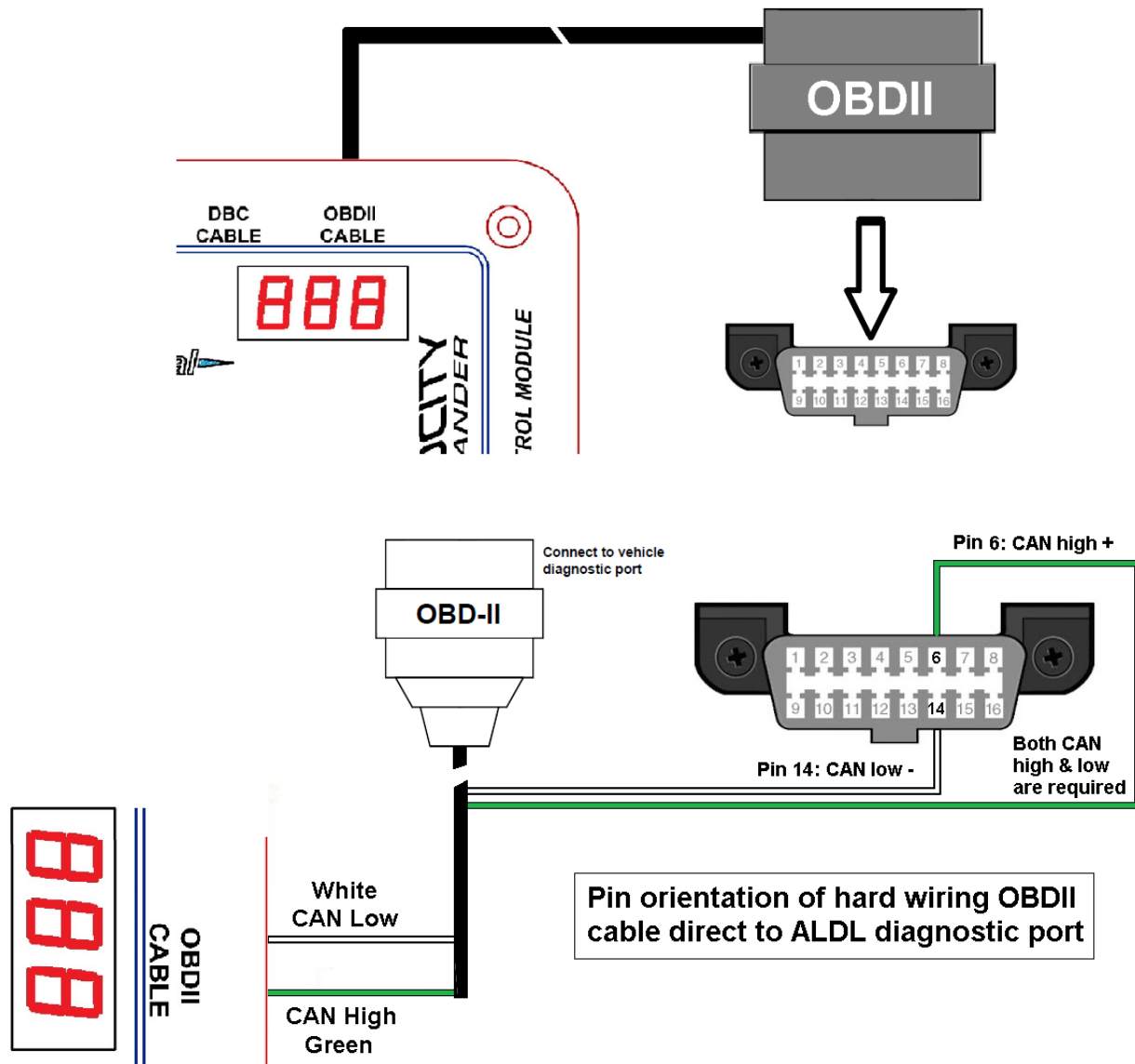

In some cases, the CAN High + and CAN Low - wires could be soldered direct to the OBDII harness. This will allow for the OBDII port to remain open, or be used by a Dakota Digital BIM-01-2.

SAE CAN bus uses pins 6 and 14.

Cut the large plug off and **solder** the Green wire to pin 6 and the White wire to pin 14

If interfacing with an EFI system, plug one end of the EFI Y-harness into the OBDII CABLE port, and plug one of the Y-ends into the EFI system's CAN connector. The leftover connector on the Y-harness is typically used to plug in a handheld dash/display, or may be used to plug into a Dakota Digital BIM-01-2 module.

Clutch Switch Wiring

- Optional – Only for manual transmissions.
- If using an automatic transmission **DO NOT CONNECT EITHER INPUT TO ANYTHING.**
- If using a clutch switch that is a ground trigger, **DO NOT CONNECT** the "CLUTCH+" input.
- If using a clutch switch that is a positive trigger, **DO NOT CONNECT** the "CLUTCH-" input.
- Either switch operation can be "normally open" or "normally closed" – the type is selectable in setup.
- The negative trigger clutch input could also be used to connect a neutral safety switch. In many cases the stock gear indicator or stick shift sends a ground to a relay, as well as our GSS-3000. This ground can be used to trigger the "CLUTCH -".

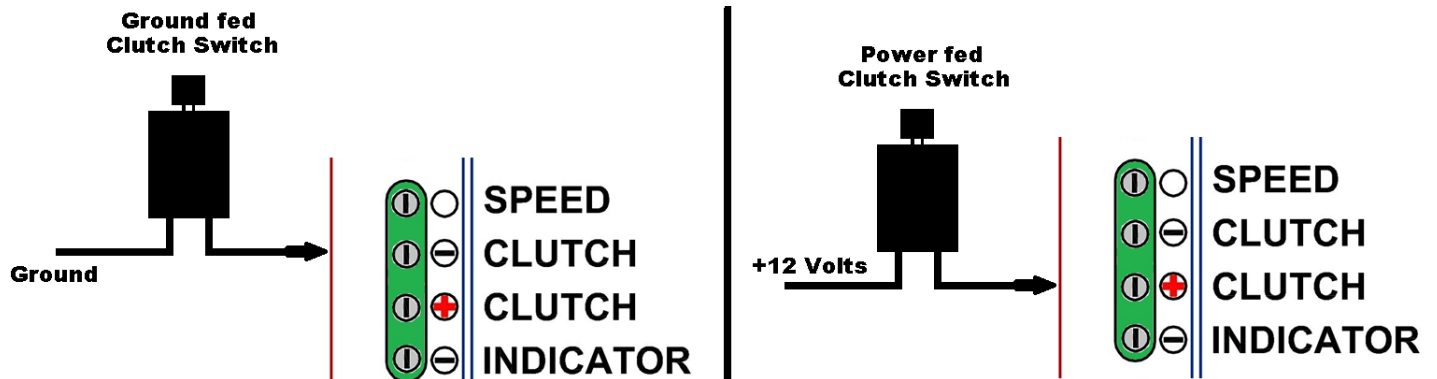

Example of clutch switch mounting.

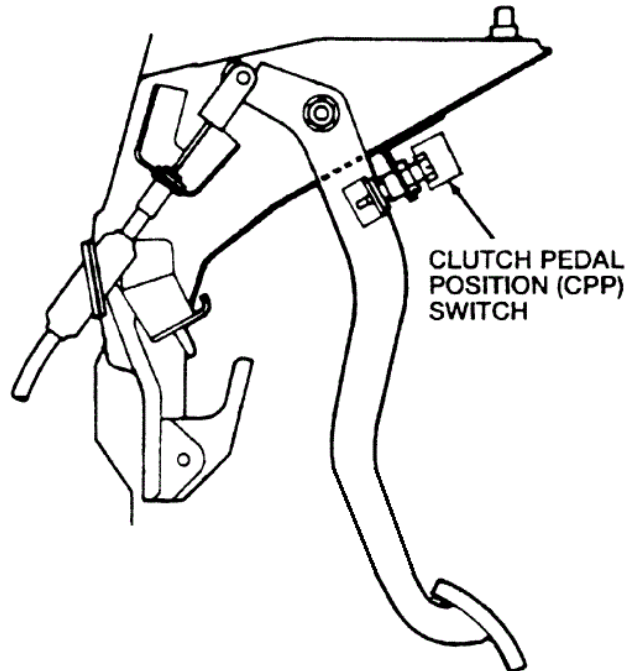

Original Brake Switch

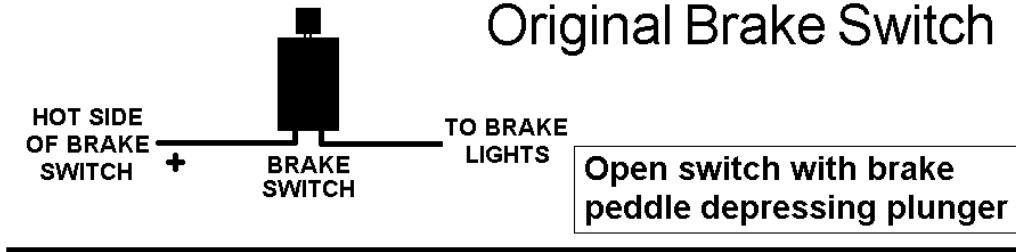

Brake Switch with Cruise added

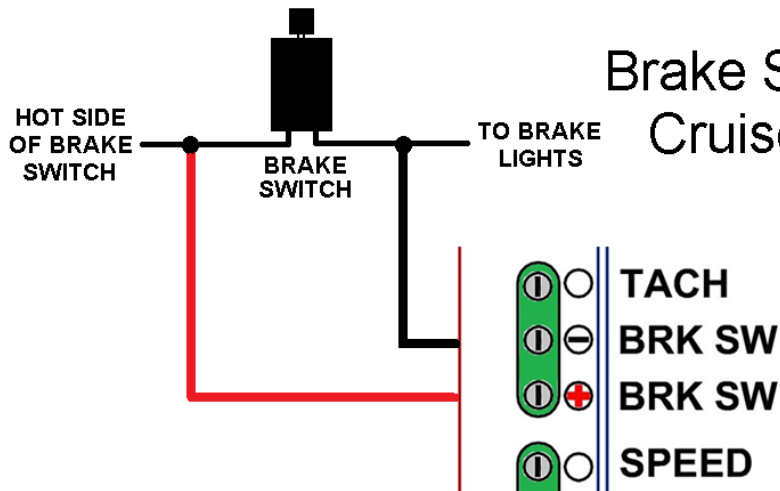

LED brake Lights

When using LED brake lights, the above wiring will need an option changed in setup. The menu option of *LED* is normally set to *nD* for incandescent bulbs. This needs to be changed to *YE5* for LED brake lights.

This will bypass a safety mechanism that only allows the cruise to engage when it sees ground from the light bulb wiring. LEDs do not act the same as regular bulbs and do not provide a ground when brake lights are off. This means the cruise is ignoring the lack of ground and could engage even when the brake lights are not wired in or are not functioning.

As long as the -BRK SW terminal sees power from the brake switch with the pedal depressed, the cruise will disengage when the brake pedal is applied.

Handle Wiring

HND-1 or HND-3

The HND-1 and HND-3 switch handles will come with a connector and pins on the wires. The connectors will not be used with the VCM cruise module. Cut the pins off of the wires and strip them back approximately ¼ inch to be inserted into the screw terminals on the VCM. The diagram below shows the screw terminal where each wire color should be connected.

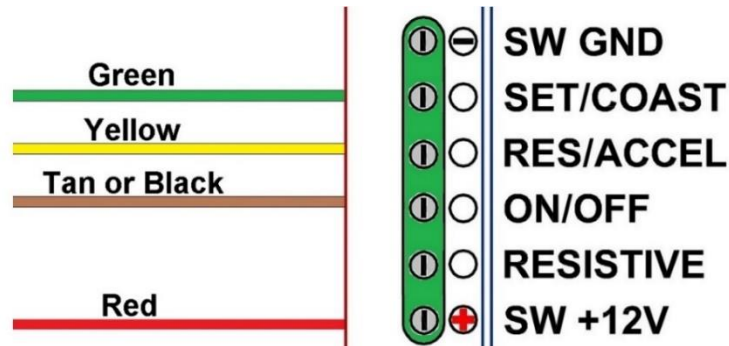

HND-2

The HND-2 switch will come with a connector and pins on the wires. The connectors will not be used with the VCM cruise module. Cut the pins off of the wires and strip them back approximately ¼ inch to be inserted into the screw terminals on the VCM. The diagram below shows the screw terminals where each wire color should be connected along with additional wiring needed to power up the HND-2.

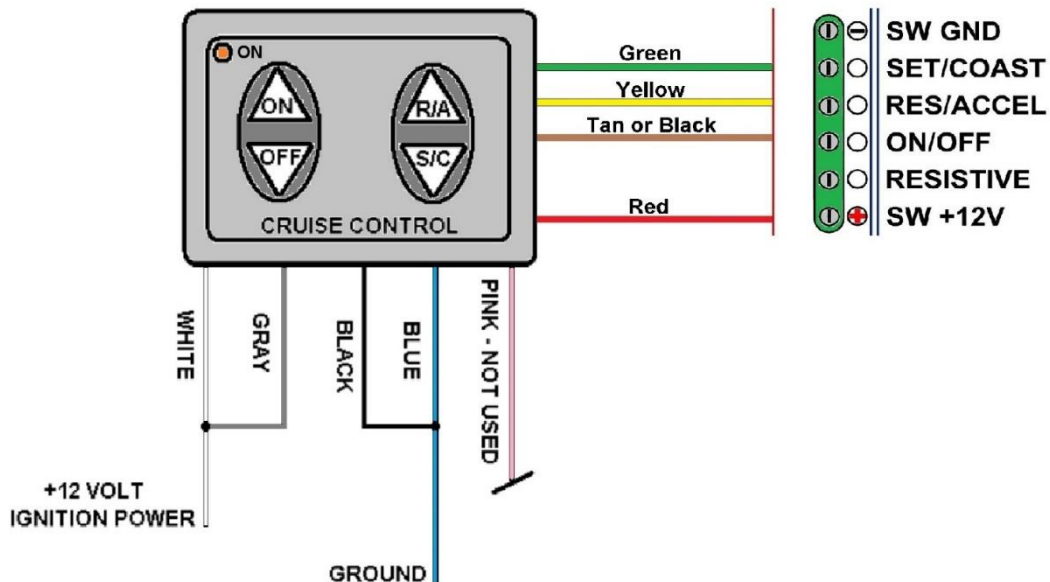

Handle Wiring

OEM Handles

The VCM can be used with a variety of OEM handles. These can be momentary normally open or normally closed contact switches or a resistive style switch such as those commonly used on Ford vehicles. To use these switches, you must do a switch learn procedure which can only be done through the Dakota Digital application for your phone or tablet. You must find out which wires are the power wires; we will learn the button operation.

The OEM GM switches can be supported if they have the following switches. On/Off, Set/Coast and Resume/Accelerate. These switches need to be wired into the “SET/COAST”, “RES/ACCEL” and “ON/OFF” inputs as shown in the diagram below. Ideally you would connect each switch to its appropriate input. However, you can connect any of the 3 wires to any of the 3 inputs and the VCM can learn the switches. In addition to the 3 switch wires should be connected to the SW +12V terminal on the module. Once connected, perform the switch learn process from the Dakota Digital app.

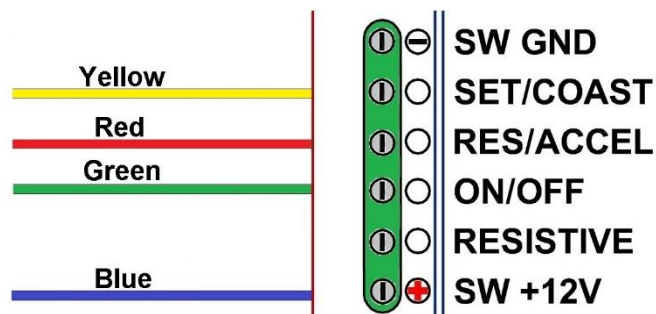

GM four wire switch/handle colors may vary and these are some possible options

Function	GM Colors	GM Colors	GM Colors	GM Colors
Resume/Accel	Yellow	Gray/Black	Green	Dark Gray
Set/Coast	Red	Blue	Blue	Dark Blue
On	Green	Gray	Gray	Gray
Power in	Blue	Pink	Pink	Pink/Black

The OEM resistive switches will have one signal wire connected to the “RESISTIVE” input, and the other connected to the “SW GND” input. See the diagram below. Some manufacturers of resistive switches will have a third ON wire (Ford had used Yellow or Purple) which should be wired to the SW +12V input. Once connected, perform the switch learn process from the Dakota Digital app.

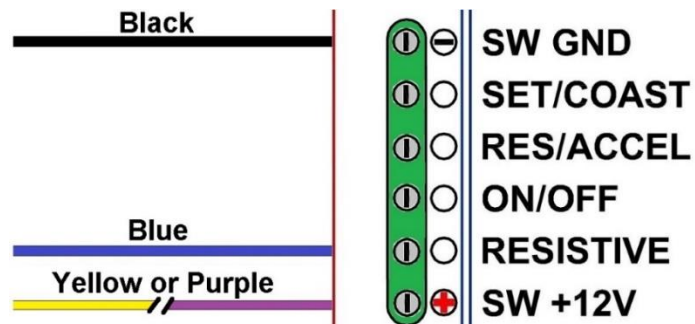

Throttle Pedal Harness

There are pedal harnesses available for Drive-By-GM, Ford and Mopar applications. The throttle pedal harnesses are a plug and play style. The connectors must be the proper mating connector and wiring for the pedal used.

The image below shows connections for the GM pedal harness. Ford/Mopar wire colors may vary.

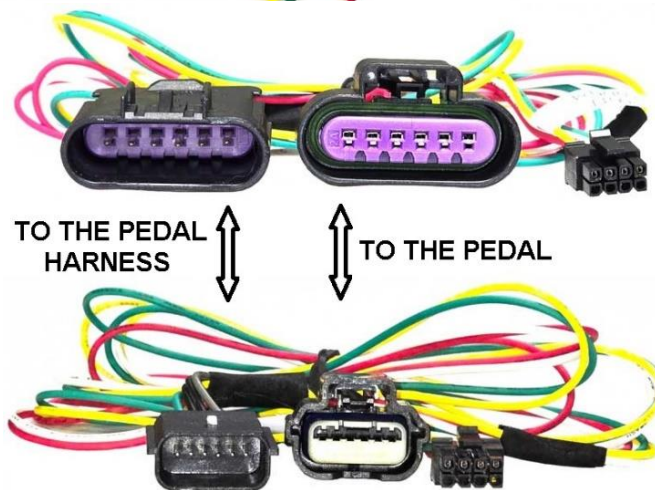
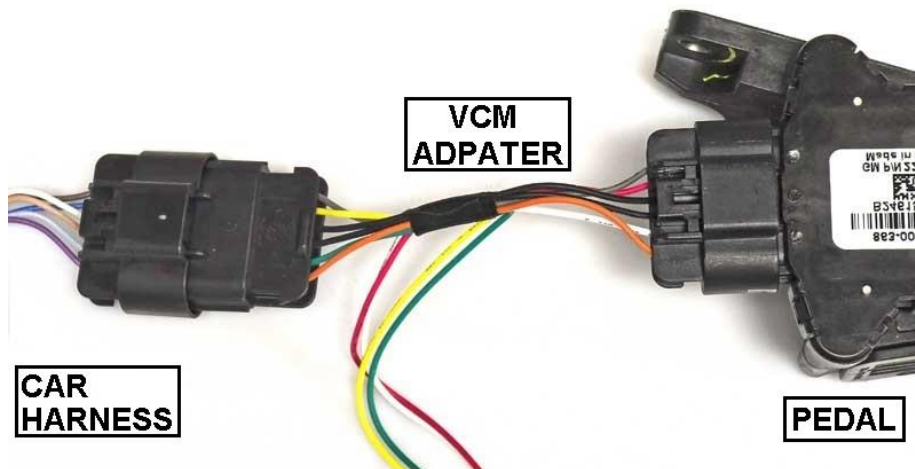
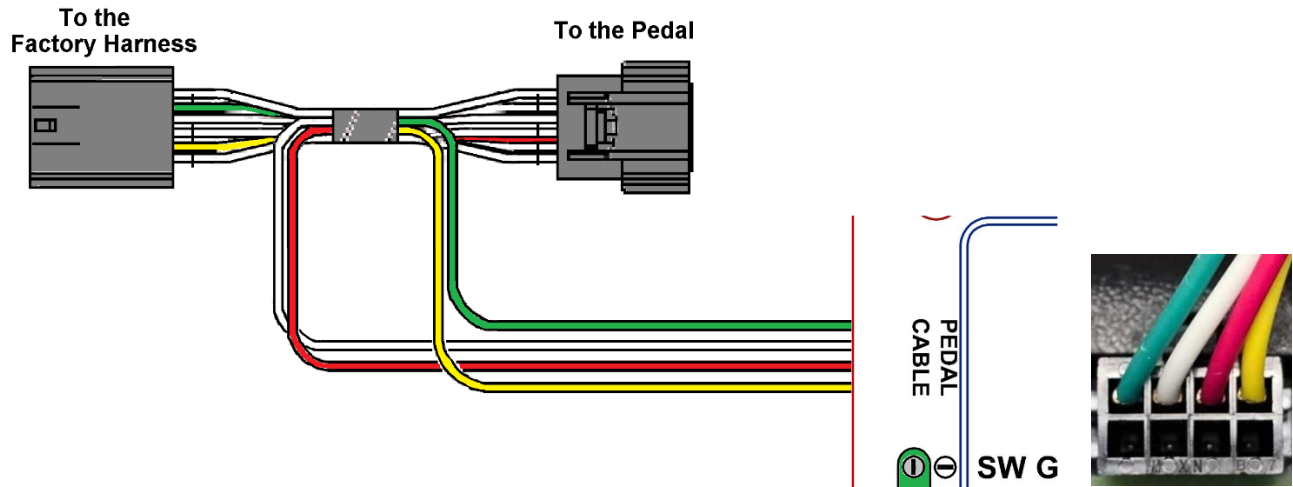

GM Throttle Wire Colors

GM colors and certain pins can be different, let alone aftermarket harness colors.

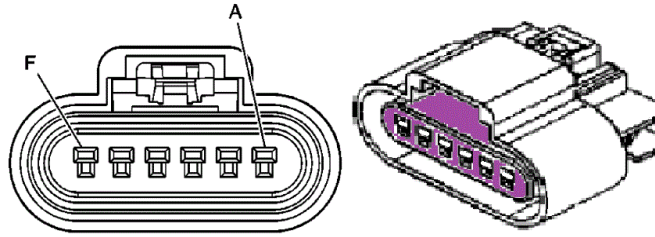

The GM throttle pins are labeled A through F.

B and **E** are the variable voltages the ECU needs to see to operate.
The VCM varies the same voltages to control speed of the vehicle.

A, C, D, and F can be a mix of ground or power, as our throttle harness merely acts as a pass through.

Pedal Crossover Harness

Certain models of pedal require pins B and E to be reversed. If necessary, the 394309-06 crossover harness is included for this purpose. If the display flashes an E4 error after learning pedal voltages, or if the Dakota Digital app requests that the crossover harness be installed, please install it between the VCM and the 8-way connector on the end of the pedal harness.



Speed Signal Wiring

If not using the OBDII or CAN bus for speed data you can connect a speed signal to the “SPEED” input. When using this input, you will need to go into setup and select the signal input and set the PPM (pulses per mile) for the signal being connected. If the PPM is not known or is not in the list of selectable values you can use the Dakota Digital application to learn the PPM of the signal. More details available in the “Speed Setup” section of the manual.

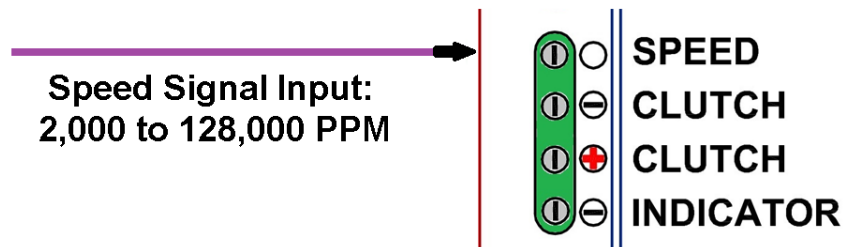

Tach Signal Wiring

If not using the OBDII or CAN bus for Tach data you can connect a tach signal from a gasoline engine to the "TACH" input. When using this input, you will need to go into setup and select the signal input type.

If the signal type is SIG for a tach wire connecting to the VCM, select the proper cylinder count from the options of: 4, 6, 8, 10, and 12. Most V-8 engines are 8 but an LS is typically 4 from the ECU wire.

If you are familiar with Pulse Per Revolution for tach signals, the PPR is half of the cylinder count.

This an important option for manual transmissions to disengage the cruise if the engine over revs from the clutch pedal being depressed, before the brake pedal, if the clutch wiring is not used.

- On vehicles using a separate ignition coil, connect to the negative side of the coil. The negative side of the coil will be the wire that goes to the points or electronic ignition module.
- For GM HEI ignition equipped engines, connect to the terminal marked "TACH" or on some systems, a single white wire with a spade terminal on it.
- On some aftermarket ignition systems, connect to the TACH output terminal, or wire.
- On an HDX, RTX or GRFX use the TACH OUT if the TACH input is being fed a source. Match cylinder count to the HDX, RTX or GRFX cylinder count.
- On computer-controlled ignition systems, consult a service manual for the wire color and location.
 - LS engine will use 4 Cyl and 5 volts, unless a BIM-01-2 series is used.
- With a magneto system, connect to the kill wire for the tach signal.
- Not for use with diesel tach signals without using the SGI-100BT Interface.

To ensure that the ignition system does not interfere with any other dashboard functions, do not run the tachometer wire alongside any other sensor or input wires.

DO NOT USE SOLID CORE SPARK PLUG WIRES WITH THIS CRUISE CONTROL.

Solid core ignition wires cause a large amount of electromagnetic and radio frequency interference which can disrupt the system operation.

Do not connect the TACH terminal to the secondary, or high voltage side of the ignition coil.

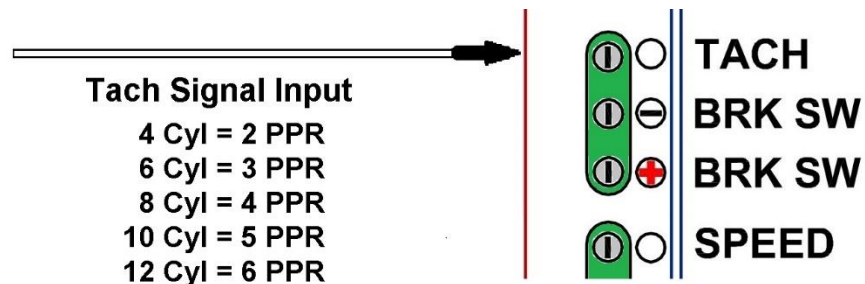

SETUP MENU

To enter setup press and hold the SETUP SW on the side of the module and turn on the ignition power. Navigating through the menu structure, you will use a series of taps and holds of the SW.

Tapping the SW will move through the menu options, like clicking a mouse.

Holding the SW will either enter a menu or save an option, and will show “---” when complete.

- **NOTE: if selecting an OBDII or EFI CAN bus option, and you are going to use a tach signal from the data bus also, then the tach option MUST match the speed option.**
EG: Speed = F1 then tach must be set to F1 also (if tach will be used).

Main Menu	Level 1 Sub-Menu	Level 2 Sub-Menu	Level 3 Sub-Menu	Description
<i>Ⓛod</i>				Hold Setup SW to display the software version
	<i>17</i>			Software version, tap to display <i>bAⓁ</i>
	<i>bAⓁ</i>			Back, hold the SW to return to <i>Ⓛod</i>
<i>Ⓛrt</i>				Cruise Type, hold to enter the cruise type menu
*	<i>ECU</i>	(Default)		Engine control unit, Tap SW to make scroll through choices, or Hold SW to learn the cruise pedal type to DBW (drive by wire)
		<i>PEd</i>		Pedal menu, hold SW to enter the pedal learn menu to learn the “at rest” and “depressed” pedal voltages
			<i>rPⓁ</i>	Rest pedal voltage, make sure the pedal is not depressed then hold the SW to learn the at rest pedal voltage. Release the switch to show <i>dPⓁ</i> .
			<i>dPⓁ</i>	Depressed pedal voltage, press the pedal all the way to the floor then hold SW to learn the depressed pedal voltage. Release the switch to return to <i>bAⓁ</i> .
			<i>bAⓁ</i>	Back, hold the SW to return to <i>PEd</i>
		<i>bAⓁ</i>		Back, hold the SW return to <i>ECU</i>
	<i>ⓁbL</i>			Cable, hold SW to set the cruise type to DBC (drive by cable). Release the switch to return to <i>bAⓁ</i> .
	<i>bAⓁ</i>			Back, hold SW to return to <i>Ⓛrt</i>
<i>ⓁrS</i>				Cruise Switch type, Hold SW to enter the cruise switch type menu. Tap SW to make scroll through choices.
	<i>h1</i>			HND-1, Hold SW to select HND-1 as the type of switch used with the VCM. Release the switch to return to <i>bAⓁ</i> .
*	<i>h2</i>	(Default)		HND-2, Hold SW to select HND-2 as the type of switch used with the VCM. Release the switch to return to <i>bAⓁ</i> .
	<i>h3</i>			HND-3, Hold SW to select HND-3 as the type of switch used with the VCM. Release the switch to return to <i>bAⓁ</i> .
	<i>rES</i>			Resistive, Hold SW to select a resistive switch type. This will set the VCM to work with typical Ford resistive switches. Release the switch to return to <i>bAⓁ</i> .
	<i>nrS</i>			Non-Resistive (typical GM or Mopar) switch, hold SW to select this switch type. Release to enter sub-menu. Tap SW to scroll through choices.
		<i>OFF</i>		Off, hold SW to learn the state of the “Off” switch. Releasing the switch will take you to <i>0n</i> .

		<i>On</i>		On, hold SW to learn the state of the “On” switch. Release the switch to return to <i>SEt</i> .
		<i>SEt</i>		Set, hold SW to learn the state of the Set/Coast switch. Release the switch to return to <i>rES</i> .
		<i>rES</i>		Resume, hold SW to learn the state of the Resume/Accel switch. Release the switch to return to <i>bAC</i> .
		<i>bAC</i>		Back, hold SW to return to <i>CLt</i>
	<i>bAC</i>			Back, hold SW to return to <i>CrS</i>
<i>CLt</i>				Clutch switch type, Cruise Type, hold SW to enter the clutch switch type menu. Tap SW to make scroll through choices.
*	<i>oFF</i>	(Default)		Hold SW to disable the clutch inputs. Releasing the switch will take you to <i>bAC</i> .
	<i>noP</i>			Hold SW to enable the Clutch+ input for use with normally open switch. Release the switch to return to <i>bAC</i> .
	<i>nCP</i>			Hold SW to enable the Clutch+ input for use with normally closed switch. Release the switch to return to <i>bAC</i> .
	<i>non</i>			Hold SW to enable the Clutch- input for use with normally open switch. Release the switch to return to <i>bAC</i> .
	<i>nCn</i>			Hold SW to enable the Clutch- input for use with a normally closed switch. Release the switch to return to <i>bAC</i> .
	<i>nEU</i>			Hold SW to enable the Clutch- input for use with a grounding neutral safety switch. Release the switch to return to <i>bAC</i> .
	<i>bAC</i>			Back, Hold SW to return to <i>CLt</i>
<i>LEd</i>				LED, Hold SW to enter the LED tail lights menu Tap SW to make scroll through choices.
	<i>YES</i>			Hold SW to enable when using LED tail lights. Release the switch to return to <i>bAC</i> .
*	<i>no</i>	(Default)		Hold SW to disable when using regular incandescent bulb tail lights. Release the switch to return to <i>bAC</i> .
	<i>bAC</i>			Back, Hold SW to return to <i>LEd</i>
<i>SPd</i>				Speed, Hold SW to enter the speed input menu. Tap SW to move to CAN options, hold to enter VSS signal menu.
	<i>S 19</i>			Signal, hold SW to enable the SPEED input for using VSS signal as the speed source. Releasing the switch will take you to currently selected value.
		<i>2.0</i>		2000PPM, Hold SW to set the PPM value for the VSS signal to 2000PPM
		<i>4.0</i>		4000PPM, Hold SW to set the PPM value for the VSS signal to 4000PPM
		<i>8.0</i>		8000PPM, Hold SW to set the PPM value for the VSS signal to 8000PPM
		<i>16.0</i>		16000PPM, Hold SW to set the PPM value for the VSS signal to 16000PPM
		<i>128</i>		128000PPM, Hold SW to set the PPM value for the VSS signal to 128000PPM

		<i>Lrn</i>		Learn, Hold SW to enter the routine for learning the PPM value for your VSS signal. Release when you see “---”.
			<i>bE9</i>	Begin, Hold SW until “---”. Release to display “000”. Begin to drive the mile.
			<i>000</i>	Cal, <i>000</i> will be displayed. Once you start driving the number will increase, as the VCM counts pulses. The count is by 100. An expected 8,000 pulse will read as 80. Anything higher than 99,900 will be divided by 1,000. Minimum pulse rate is 1,500 PPM. E 2 will display if pulse rate is below 1,500 (0 15) Hold SW to end of the mile run to display “---”. Releasing the switch will take you to <i>bAC</i>
			<i>bAC</i>	Back, Hold SW to return to <i>Lrn</i>
		<i>bAC</i>		Back, Hold SW to return to <i>5 19</i>
*	<i>abd</i>	(Default)		OBDII, Hold SW to select OBDII data as the source for speed. Release to show <i>bAC</i>
	<i>Frd</i>			Ford Performance (Control Pack) CAN Bus. Proprietary Ford CAN signal, used on certain Coyote crate engines
	<i>cus</i>			Custom CAN. This is an advanced CAN option that is not a predetermined standard. The detailed options to configure the VCM to the ECU data is best done in the app.
	<i>F1</i>			Holley EFI, Hold SW to select the Holley EFI (not Sniper or Sniper 2) CAN bus data for speed input. Release to show <i>bAC</i>
		<i>595</i>		Holley system select, Hold SW to enter the system select menu
			<i>rAC</i>	Racepak CAN protocol, hold SW to select
			<i>Std</i>	Holley Standard CAN protocol, hold SW to select
			<i>bAC</i>	Back, Hold SW to return to <i>595</i>
		<i>InP</i>		Holley Input 1 speed enable, only in menu when <i>595</i> is set to <i>Std</i>
			<i>SPd</i>	Holley Input #1 speed on, VSS is connected to Holley Input #1 J1A, Pin A12
			<i>oFF</i>	Holley Input #1 speed off, VSS is connected to Holley Input #39, J4, Pin B18
			<i>bAC</i>	Back, Hold SW to return to <i>InP</i>
		<i>bAC</i>		Back, Hold SW to return to <i>F1</i>
	<i>F2</i>			AEM EFI, Hold SW to select the AEM EFI CAN bus data for speed input. Release to show <i>bAC</i>
	<i>F3</i>			MegaSquirt EFI, Hold SW to select the MegaSquirt EFI CAN bus data for speed input. Release to show <i>bAC</i>
	<i>F4</i>			Haltech EFI, Hold SW to select the Haltech EFI CAN bus data for speed input. Release to show <i>bAC</i>
	<i>F5</i>			FiTech EFI, Hold SW to select the FiTech EFI CAN bus data for speed input. Release to show <i>bAC</i>
	<i>F6</i>			Aces EFI, Hold SW to select the Aces EFI CAN bus data for speed input. Release to show <i>bAC</i>
	<i>bAC</i>			Back, a long press will to return to <i>SPd</i>
<i>tAC</i>				Tach selection option: hold SW to enter

	5 19			Signal (ECU wire, coil or HEI) Hold SW to set for conventional tach signal. Release to show cyl
		cyl		Cylinder count: hold SW to show "---". Release to show cylinder count. Tap through cylinder count.
			4	Hold SW to select for a 4-cylinder engine or LS with tach wire. Release when "---" is displayed to go to bAC
			6	Hold SW to select for a 6-cylinder engine. Release when "---" is displayed to go to bAC
			8	Hold SW to select for a 8-cylinder engine. Release when "---" is displayed to go to bAC
			10	Hold SW to select for a 10-cylinder engine. Release when "---" is displayed to go to bAC
			12	Hold SW to select for a 12-cylinder engine Release when "---" is displayed to go to bAC
			bAC	Back, Hold SW to return to cyl
		LUL		Voltage Level input: hold SW to enter menu
			12v	12 Volt signal: reading from points coil or HEI. Hold SW to save. Release when "---" is displayed to go to bAC
			5v	5 Volts signal: reading low voltage tach from ECU. Hold SW to save. Release when "---" is displayed to go to bAC
			bAC	Back, Hold SW to return to LUL
	obd			OBDII, Hold SW to select OBDII data as the source for tach data. Release to show bAC
	Frd			Ford Performance (Control Pack) CAN Bus. Proprietary Ford CAN signal, used on certain Coyote crate engines
	CUS			Custom CAN. This is an advanced CAN option that is not a predetermined standard. The detailed options to configure the VCM to the ECU data are available in the app.
	F 1			Holley EFI, Hold SW to select the Holley EFI CAN bus data for speed input. Release to show bAC
		5Y5		Holley system select, Hold SW to enter the system select menu
			rAC	Racepak CAN protocol, hold SW to select
			Std	Holley Standard CAN protocol, hold SW to select
			SPr	Sniper CAN protocol. Note: Sniper systems do not send speed over CAN, so the speed source will be set to Signal if this option is selected.
			bAC	Back, Hold SW to return to 5Y5
		bAC		Back, Hold SW to return to F 1
	F2			AEM EFI, Hold SW to select the AEM EFI CAN bus data for tach data input. Release to show bAC
	F3			MegaSquirt EFI, Hold SW to select the MegaSquirt EFI CAN bus data for tach data input. Release to show bAC
	F4			Haltech EFI, Hold SW to select Haltech EFI CAN bus data for tach data input. Release to show bAC
	F5			FiTech EFI, Hold SW to select the FiTech EFI CAN bus data for tach data input. Release to show bAC
	F6			Aces EFI, Hold SW to select the Aces EFI CAN bus data for tach data input. Release to show bAC
*	oFF	(Default)		Off, Hold SW to disable using the tach.
	bAC			Back, Hold SW to return to rAC

<i>SEn</i>				Sensitivity, Hold SW to enter the sensitivity menu. Sensitivity sets how aggressive the VCM is at correcting for speed. Selectable values from 1-5 with 1 being least aggressive. Releasing the switch will take you to the current setting.
	1			Least aggressive speed correction, Hold SW to set the sensitivity to this. Release to show <i>bAC</i>
	2			Hold SW to set the sensitivity to this. Release to show <i>bAC</i>
*	3	(Default)		Hold SW to set the sensitivity to this. Release to show <i>bAC</i>
	4			Hold SW to set the sensitivity to this. Release to show <i>bAC</i>
	5			Most aggressive speed correction, Hold SW press to set the sensitivity to this. Release to show <i>bAC</i>
	<i>bAC</i>			Back, a long press will to return to <i>SEn</i>
<i>rSt</i>				Reset, Hold SW to enter the reset menu
*	<i>no</i>	(Default)		No, Hold SW to NOT reset. Release to show <i>bAC</i>
	<i>YES</i>			Yes, Hold SW to reset. Release to show <i>bAC</i>
	<i>bAC</i>			Back, a long press will to return to <i>rSt</i>
<i>LOC</i>				Lock for Bluetooth, hold SW to enter lock menu.
*	<i>nD</i>	(Default)		Lock for Bluetooth: Hold SW to unlock Bluetooth to access setup without holding the setup switch first. Release to show <i>bAC</i>
	<i>YES</i>			Lock for Bluetooth: Hold SW to lock Bluetooth to only allow access if the VCM is in setup mode (holding SW then key on). Release to show <i>bAC</i>
	<i>bAC</i>			Back, Hold SW to return to <i>LOC</i>
<i>End</i>				End, Hold SW to exit the setup function and return to normal operation.

EFI SYSTEM SETUP

If an EFI system is used as a speed or tach input, there may be additional setup steps needed, depending on the EFI system.

Holley:

NOTE: Sniper models do not offer a speed signal on the CAN bus.

Terminator X/X Max, HP, Dominator, and Terminator (original)

For the VCM-100 to function correctly with these systems, ensure the Holley CAN settings are set to “Holley Standard.” These settings are adjusted through Holley’s PC software.

1. Select ‘System ICF’ tab along the top icon menu.
2. Then select ‘Basic I/O’ on left menu.
3. Then select ‘CAN Bus’ on the right to show ‘CAN Bus 1 Type’ and ‘CAN Bus 2 Type’.
4. Select the dropdown and select “Holley Standard”.
 - o Terminator or HP ECU – Both 1 and 2 must be set to ‘Holley Standard’
 - o Dominator ECU – Set 1 or 2 to ‘Holley Standard’ and connect BIM cable to that CAN 1 or 2 cable

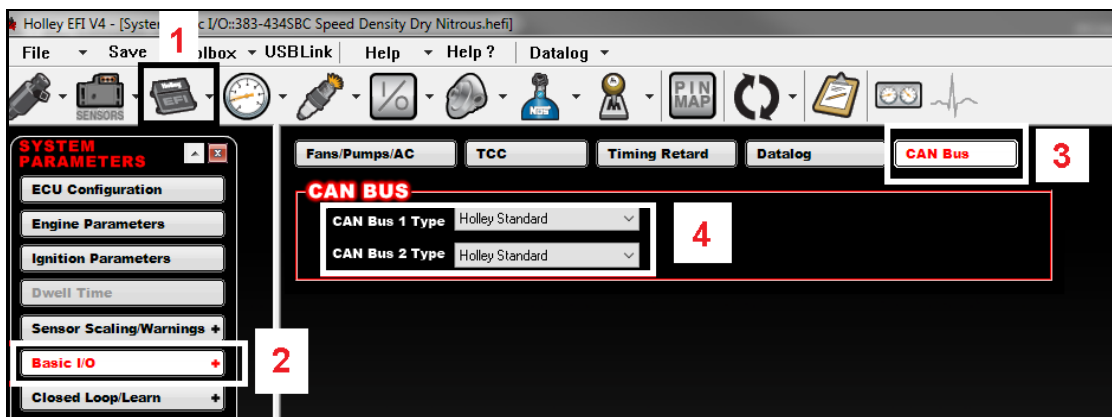

Speed Setup:

By default, the VCM-100 Holley mode is programmed to monitor the GM 4L60E/4L80E Transmission harness VSS input on pin B18 of connector J4. Connector J4 is only available on Dominator, original Terminator, and Terminator X Max models.

For ECU models without this connector, the VCM-100 is also capable of monitoring a Frequency (F) type speed signal on Input #1 (connector J1A pin A12).

If the speed signal is connected to Input #1 on J1A, pin A12:

- In the Holley I/O ICF, Input #1 must be labeled as **Speed**, and type must be set to “**DIGITAL SPEED/FREQ**”.
- In the **Configure** menu for Input #1, the Type option must be set to Miles/Hour. Calibration items such as pulses per rotation and tire diameter may be adjusted in this menu, if needed:

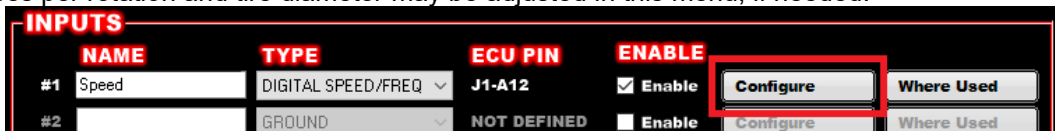

- In the **PIN MAP** menu, the **Speed** input must be assigned to Pin A12, Input #1 (Connector J1).

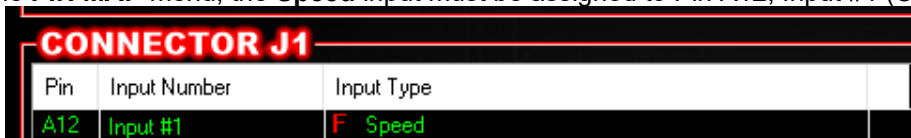

- On the VCM-100, the Holley speed input setting (*InP*) must be set to Input #1 (*In I*).

If the speed signal is connected to the Trans. harness VSS input on J4, pin B18:

- A Holley Transmission ICF must be configured and active.
- The VCM-100 Holley speed input setting (*inP*) must be set to Trans. VSS (*v55*)

These settings will enable speed to be transmitted on the Holley CAN bus.

AEM:

This system is plug-and-play. Attach the AEM Y-harness to your AEMnet device. No further setup is required.

MegaSquirt:

To enable the transmit of speed and tach data to the VCM-100, in the TunerStudio software, enter the CAN-bus/Testmodes->CAN Parameters, and set the Master Enable setting to On. Then, enter the CAN-bus/Testmodes->Dash Broadcasting menu, and set the Enable setting to On.

Haltech:

This system is plug-and play. Attach the Haltech Y-harness to your Haltech Elite or Nexus ECU. No further setup is required.

FiTech:

The VCM-100 is compatible with FiTech LS and TCU systems with the 2.5mm TRRS CAN bus jack. To enable the transmit of speed and tach data from the FiTech system to the VCM-100, use the FiTech handheld to enter the FiTech Initial Setup->CAN OUTPUT menu, set the “61444 RPM” and “65270 Speed” settings to “On”, then tap the “Send to ECU” button.

Aces:

This module is compatible with Aces systems that feature built-in Trans control. Aces ECU software must be version 2.18 and later (7” Pro Dash version 2.37 and later). Please note that if the Aces handheld is used, viewing menus with live data will cause the Aces system to stop transmitting Speed data to the VCM-100. To resolve, unplug the Aces handheld, or switch to a menu that does not show live data.

Using The Dakota Digital App

The Dakota Digital application can be used for VCM Setup and Diagnostics. The application allows for setup of the more advanced features that can't be done through the display and setup switch.

The "Dakota Digital" app is free from the Apple App Store or Google Play.

With key power on, open the app and it will begin to search for active Dakota Digital devices. The VCM will show up in the list of devices with a prefix of DDXC- followed by 4 digits. The 4 digits are unique for each VCM. Tap the box starting with DDXC- to connect to the VCM. You will see a message pop up asking to confirm you want to be in setup mode. Tap YES to proceed.

By default, the VCM does not need to be in setup mode for the app to connect, unless the **LOC** option was changed to **YES** in the manual setup of the VCM, (see page 20). If the app does not find the device starting with DDXC- then put the VCM in setup by holding the setup switch while turning the key on, and try again.

Once connected you will see a screen that has buttons for Setup, Diagnostics and Information.

NOTE: The VCM will not engage if the app is connected and in setup mode. If the app connects while the cruise is engaged, it will disengage the VCM. Press the "Exit Setup" to save and exit setup, and the VCM will reboot. Closing the app or pressing "Disconnect" will leave the VCM in setup mode.

Setup

Click the Setup button on the main screen to enter the Setup screen. In the Setup screen you will have buttons for Bluetooth, Manual Setup, Setup Wizard, Sensitivity and Factory Reset.

Bluetooth

Click on the Bluetooth button to enter the Bluetooth setup screen. In this screen you can change the name for the device to something that is easy for you to remember. The Safe Mode option allows locking of the setup menu. By default, Safe Mode is disabled, and the app may be used to enter the setup menu at any time. If Safe Mode is enabled, it is only possible to enter the setup menu by holding the setup switch on the control box and applying power (key-on).

Manual Setup

Click on Manual Setup to enter the manual setup screen.

Cruise Type: The selections available are drive by wire or mechanical. If your setup does not have a mechanical linkage to the throttle body you would select the BY WIRE setting. If you do have mechanical linkage select MECH.

If By Wire is chosen a Learn Pedal button will show up. You will need to perform this pedal learn. Click the button and follow the instructions in the app.

Cruise Sw Type: Select the type of switch you are using to control the VCM from this list. You can select between the 3 types of handles/switches available from Dakota Digital or you can select OEM to use an existing switch. The VCM will work with a number of resistive and non-resistive OEM handles. Resistive style switches would typically have a power and ground connection and one signal connection. Non-resistive switches will typically have power and ground and 3 switch connections. See Handle Wiring in the STEP BY STEP CONNECTIONS section.

If OEM is selected you will see a Learn Non-Resistive Switches or Learn Resistive Switches button. You will need to perform the learn process so the VCM knows how to read the switches. Click the button and follow the pop-up instructions in the app if the switch is resistive or not.

Clutch Input: If you are using a manual transmission and want the cruise to disengage when the clutch is pressed select the type of switch from this list. Available options are Pos Trigger, Neg Trigger, Neutral Safety and Off. Positive trigger indicates the clutch switch would apply +12V when the clutch is pressed and negative trigger would indicate the switch connects to ground when the clutch is pressed. The neutral safety option can be used with automatic or manual transmissions that have a neutral safety switch that pulls to ground when in neutral. Pos Trigger and Neg Trigger options have N.O (normally open) or N.C (normally closed) options, to match the type of clutch switch used.

LED Tail Lights: Click the “Yes” button if you have LED tail lights and the “No” button if you do not.

Setup Speed Input: Clicking the drop down will display choices to scroll through.

Select one from the list

Signal	Discrete speed signal from a wire
OBDII	OBDII CAN Bus only
Ford Perf.	Ford Performance (Control Pack) CAN Bus
Custom CAN	Customized CAN input (advanced setup)
EFI1	Holley (all except Sniper)
EFI2	AEM
EFI3	Megasquirt
EFI4	Haltech
EFI5	FiTech
EFI6	Aces

If you select Signal as your input you will need to set the PPM (pulses per mile) for your speed signal. You can select from the settings in the list, if unknown or not in the list click on the Learn PPM button to learn the pulses per mile. To learn you will be required to drive the vehicle one mile, then come to a complete stop. The VCM will count and learn the number of pulses for a mile.

If you select Custom CAN as the input, you will be required to enter a number of parameters needed for the VCM to know where to find the data and how to process it. These parameters include Baud Rate, Extended Addressing off or on, Can Endianess, CAN PID for speed data, CAN Start Bit for speed data, CAN Bit Length for speed data, CAN Scaler for speed data, CAN Offset for speed data and the CAN Units for speed. The CAN bus defaults to settings used by GM. This information can be found in .dbc files used to define how to decode CAN data for specific vehicles. Many of these can be found online.

The information for the OBDII, Ford Performance, and EFI systems is hardcoded into the VCM and will not require any additional setup by the user.

Note: The VCM can only accept data from one type of CAN bus. Speed cannot be on one bus and tach on another bus. Turning off tach or using a direct VSS input will not be affected.

Setup Tach Input: Clicking the drop down will display choices to scroll through.

Select one from the list

Signal	Discrete speed signal from a wire
OBDII	OBDII CAN Bus only
Ford Perf.	Ford Performance (Control Pack) CAN Bus
Custom CAN	Customized CAN input (advanced setup)
EFI1	Holley (all)
EFI2	AEM
EFI3	Megasquirt
EFI4	Haltech
EFI5	FiTech
EFI6	Aces

If you select Signal as your input you will need to set the engine's cylinder count for your tach signal (Note that some LS engines may need to be set to 4 cylinders). You will also need to set the tach signal level, low would be a 5VPP tach signal, and high being 12VPP or the signal off of the negative side of the coil. You will also need to set the RPM Max. This is the maximum RPM's the cruise system can push the engine to before it disengages. This is a safety feature to keep from over revving your engine in case of some kind of fault.

If you select CAN as the input, you will be required to enter a number of parameters needed for the VCM to know where to find the data and how to process it. These parameters include Baud Rate, Extended Addressing off or on, Can Endianess, CAN PID for tach data, CAN Start Bit for tach data, CAN Bit Length for tach data, CAN Scaler for tach data and CAN Offset for tach data. The CAN bus defaults to settings used by GM. This information can be found in .dbc files used to define how to decode CAN data for specific vehicles. Many of these can be found online.

The information for the OBDII and EFI systems is hardcoded into the VCM and will not require any additional setup by the user.

The tach can also be set to Off. This bypasses the feature intended to keep from over revving the engine due to faults. However, when set to off the user should have adequate time to recognize this is occurring and disable the cruise by applying the brake or pressing the off switch.

Setup Wizard

If you click the Setup Wizard button the application will walk you through the steps of setting up the cruise control. This is meant to make sure you have configured all necessary setting to get your cruise operational vs. going through the Manual Setup. Follow the instructions in the application to setup the VCM.

Sensitivity

Click the button to bring up the sensitivity setting. The sensitivity setting refers to how aggressively the cruise control corrects for errors in speed. This is a slider with 5 possible settings, 1-5, with 1 being the least aggressive. The default is set in the middle to 3.

It is recommended not to change this unless needed. Some examples of when to try adjusting this;

1. If significantly overshooting the set speed, or hitting high RPM's when doing a resume, you would want to turn this down to try and minimize overshoot or RPM's. Note if you turn this down too much you may hamper the ability to hold speed on steep inclines/declines.

- If the cruise is not maintaining speed on steep inclines/declines you may need to turn this setting up. This will adjust the throttle more aggressively to try and hold the speed. Note that adjusting this to be too aggressive will cause your speed to overshoot the target speed when doing a resume.

Diagnosics

The diagnostic screen can help with troubleshooting and testing the installation of the VCM. If the symbol on the Diagnostics button is red this indicates some fault or missing signal that will cause the cruise to not engage. When you go into the diagnostics screen if the text or symbol is red that is an indication of where to look for the fault. Follow the red to find the fault.

Note: When using the SPEED signal and the vehicle is not moving it will show red indicating no speed signal. This should go off when the vehicle is moving.

The first Diagnostic screen will show you software version and settings for the VCM. The advanced diagnostics button will show a list of menus, each with live readings that may be used to help diagnose problems.

The diagnostics also has a logging feature. This can be used when experiencing intermittent problems while using the cruise control. The log data includes current speed, set speed, pedal voltages, ECU voltages and Fault Flags for each of the inputs that can cause the cruise to disengage. These logs can also be emailed to the Dakota Digital Tech department to help with diagnosing any issues you may experience.

APPLYING SOFTWARE UPDATES

Update file packages can be downloaded from www.dakotadigital.com under the **Manuals/Support** → **Automotive** section

To apply software updates, extract the downloaded .zip folder, then copy the CRC-STxx.bxn file onto an empty (formatted) FAT32 formatted USB flash (thumb) drive. Any flash drive 32 GB or smaller will work.

While the module is powered off, plug the USB thumb drive into the *UPDATE* port. When power is applied, the module will check the version of the update file and apply the update if it is newer than the module's current software. Update progress is shown on the seven-segment display:

Display	Meaning
<i>E</i>	Erasing
<i>P</i>	Programming
° (upper left dot)	Update Finished
<i>oLd</i>	Update file on flash drive is older than the current software
<i>no F IL</i>	No valid .bxn update files were found

When the software update is finished, the USB drive may be removed from the UPDATE port.

- **NOTE: Do not interrupt power or unplug the USB drive while the VCM is updating.**

TROUBLESHOOTING

Handle Voltage Tests (w/power to VCM and testing at terminals)

HND-1 & 3	SW +12	ON/OFF	Set/Coast	Resume/Accel
Control Switch Position	Red Wire	Brown or Black wire	Green Wire	Yellow Wire
Off	+12V	0 V	0 V	0 V
On	+12V	+12V	+12V	0 V
Hold Set/Coast	+12V	+12V	0 V	+12V
Hold Resume/Accel	+12V	+12V	+12V	+12V

HND-2	SW +12	ON/OFF	Set/Coast	Resume/Accel
Control Switch Position	Red Wire	Brown or Black wire	Green Wire	Yellow Wire
Off	+12V	0 V	0 V	0 V
On	+12V	+12V	0 V	0 V
Hold Set/Coast	+12V	+12V	+12V	0 V
Hold Resume/Accel	+12V	+12V	0 V	+12V

HND-2 must have key on power to the White & Gray wires and the Black & Blue must be grounded

Four wire GM handles will test out similar to the HND-2, but the stock colors will differ.

Some possibilities are as follows:

Function	GM Color	GM Color	GM Color	GM Color
Power In (SW +12)	Blue	Pink	Pink	Pink/Black
On (ON/OFF)	Green	Gray	Gray	Gray
Set/Coast	Red	Blue	Blue	Dark Blue
Resume/Accel	Yellow	Gray/Black	Green	Dark Gray

LED status light

Green	On - Ready to operate	Off or short blink - loss of power or ground
Amber	On – Cruise engaged	Short flash – Switch functions, but cannot engage
Red	On – A fault is preventing engagement	

Error codes

In the event of a critical error preventing startup, the module's built-in seven segment display will blink an error code. Refer to the troubleshooting table to resolve.

Error code	Meaning
E 1	Cruise switch startup test failed
E 2	CAN bus initialization failed
E 3	Speed input (wired) was below minimum during calibration
E 4	Learned pedal voltages are incorrect

Turn signal use cancels cruise operation:

In some cases, the use of turn signals could induce a low voltage back into the brake light wiring and the cruise is led to believe the brake power is on the BRK SW line.

While the car wiring should not let this happen, it is an occasional thing seen.

Adding in this relay can isolate the low voltage feedback from falsely disengaging the cruise.

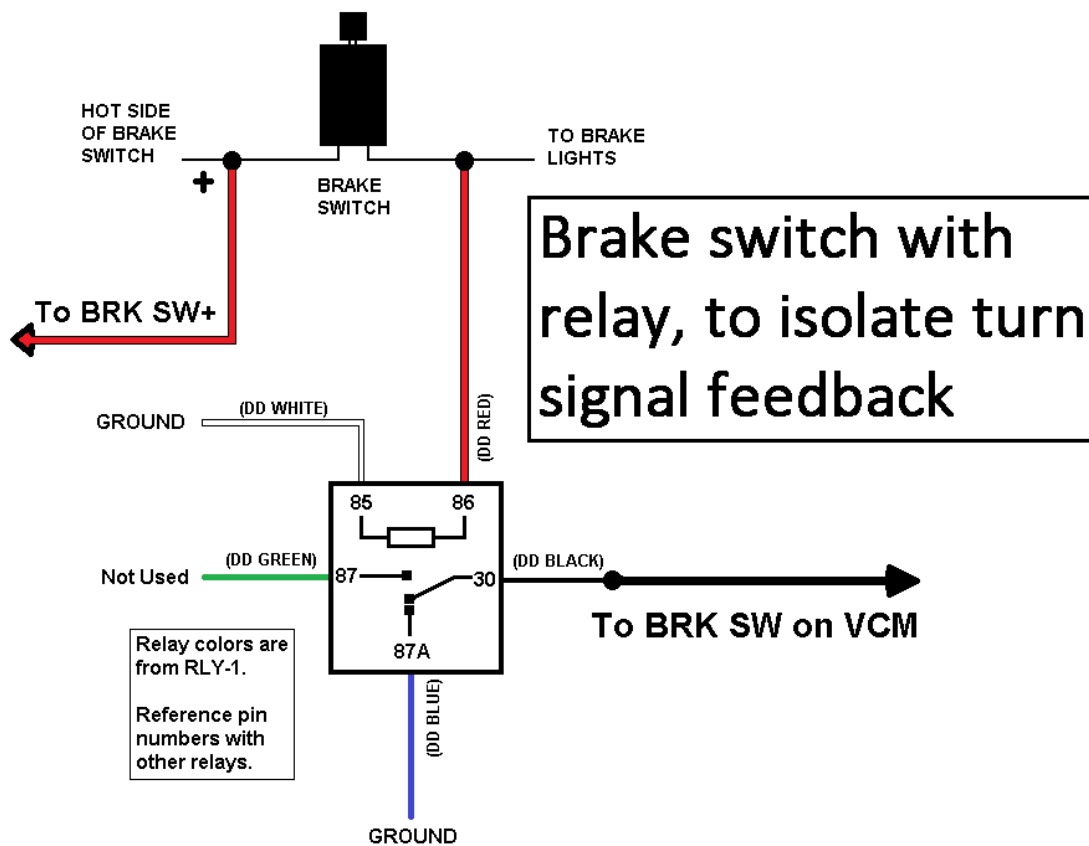

Troubleshooting Table

Problem	Possible cause	Solution
Throttle goes into "limp mode"	<ul style="list-style-type: none"> - Intermittent power - Poor ground - Need to learn pedal voltages - Began after ECU was tuned - Incorrect pedal voltage operation 	<ul style="list-style-type: none"> - Properly connect "IGNITION POWER" to proper power - Use different ground – connect ground to throttle pedal ground - Go into setup and learn pedal voltages - Restore to previous tune and troubleshoot tuning adjustments - Look up pedal voltages in the app and call support
Cruise not engaging	<ul style="list-style-type: none"> - No power on "IGNITION POWER" - No ground on "GROUND" - No ground on "-BRK SW" , "BRK FAULT" indicator on - Incorrect handle configuration - Missing "+BRK SW" - Missing or incorrect speed signal, "SPD FAULT" indicator on - Missing tach signal 	<ul style="list-style-type: none"> - Verify power on "IGNITION POWER" - Connect "GROUND" to chassis ground - Verify grounding of "-BRK SW" to conventional brake lights - Enable internal pulldown if using LED tail lights or if the brake bulb sockets are rusty - Verify handle wiring. Run handle learn to learn switches. - Make sure "+BRK SW" is connected to the hot side of the brake switch. Should have battery voltage at this connection. - Make sure the speed input has been properly configured for the speed source you are using. The "SPD FAULT" indicator will be on for the signal input until the vehicle is moving, for CAN and OBDII speed source this should go out when the vehicle is running and the VCM is seeing speed data. - Tach can be turned off if no tach signal is available. Else be sure the tach input is properly configured.
Cruise disengages when using turn signals	<ul style="list-style-type: none"> - Turn signals feeding back into brake circuit 	<ul style="list-style-type: none"> - Add relay on previous page to isolate feedback voltage
Cruise surges	<ul style="list-style-type: none"> - Throttle too sensitive - Sensitivity setting too aggressive - Learned pedal voltages are incorrect (drive-by-wire only) 	<ul style="list-style-type: none"> - HP Tuner can make the throttle less sensitive - Turn down sensitivity adjustment on VCM - Repeat the pedal learn procedure
Display flashes $E1$ error code	<ul style="list-style-type: none"> - Cruise switches held on startup - OEM Cruise handle learned incorrectly - Cruise handle switches damaged 	<ul style="list-style-type: none"> - Release the cruise switches before applying power - Repeat the OEM switch learn process - Replace the cruise handle
Display flashes $E2$ error code	<ul style="list-style-type: none"> - CAN bus initialization failed 	<ul style="list-style-type: none"> - Match CAN option to proper EFI system
Display flashes $E3$ error code	<ul style="list-style-type: none"> - Learned speed PPM out of range (signal input only) 	<ul style="list-style-type: none"> - Repeat PPM learn procedure
Display flashes $E4$ error code	<ul style="list-style-type: none"> - Learned pedal voltages are incorrect (drive-by-wire only) - Pedal harness damaged 	<ul style="list-style-type: none"> - Repeat the pedal learn procedure - Replace the pedal harness

OPERATING INSTRUCTIONS

NOTE **If the cruise indicator (-) is wired, the indicator may light for up to 10 seconds upon power up. This is normal.

ON: To operate the Cruise Control, turn the power button ON. (Green LED Indicator will light, if equipped.) Wait three (3) seconds before setting speed.

SET SPEED: To engage system, press SET/COAST for 1 - 2 seconds and release, then remove your foot from the accelerator pedal. Pressing on the accelerator will increase speed (for passing), and releasing accelerator and you will return to set speed.

COAST: Press and hold the SET/COAST button and your speed will decrease. Release button and speed of vehicle at time button is released will be new set speed.

ACCEL: Press and hold the RESUME/ACCEL button and your speed will increase. Release button and you will have a new higher set speed.

TAP-UP: You can gradually increase your speed by quickly pressing and releasing the RESUME/ACCEL button. Each time you press and release the button your speed will increase by 1 MPH.

TAP-DOWN: You can gradually decrease your speed by quickly pressing and releasing the SET/COAST button. Each time you press and release the button your speed will decrease by 1 MPH

DISENGAGE: Depress brake pedal slightly; automatic speed control will cease but set speed will stay in the system's memory. Also, you can disengage by pressing button to OFF position, but this erases the memory. To get the RESUME feature to work again, you must first set a speed. Turning OFF the ignition also clears the systems memory.

RESUME: After disengaging system with brake or clutch, press RESUME/ACCEL button and release it. If acceleration rate is faster or slower than you like, drive to within a few MPH of your set speed, then press and release the RESUME/ACCEL button.

About Dakota Digital Cruise Control

The performance of the Cruise Control is dependent upon the condition of the engine, its size and even by the type of emission control equipment it has. Driving at higher altitudes will have an effect on Cruise Control's performance.

Under normal conditions and with proper switch settings, speed should be controlled within plus or minus 1 MPH. There may be situations; however, which make it seem as if the Cruise Control is not capable of functioning accurately, such as an extra heavy load, a very steep hill, or a severe headwind.

CAUTION: Do not use the Cruise Control on a slippery road or in heavy traffic.

CAUTION: (Manual Transmission) While driving with the Cruise Control ON, do not shift to neutral without depressing the clutch pedal, as this may cause engine to over-rev. If this happens, depress the clutch pedal or turn OFF the main Cruise Control Switch immediately.

OUR QUALIFIED EXPERT TECHNICAL SERVICE DEPARTMENT IS READY TO ASSIST YOU WITH ANY QUESTIONS OR PROBLEMS THAT YOU MAY HAVE ABOUT OUR PRODUCT. CONTACT US VIA PHONE (8:00 AM to 5:00 PM CENTRAL TIME) AT (605) 332-6513 (USA), OR EMAIL techsupport@dakotadigital.com

SPECIFICATIONS

IGNITION PWR input voltage: 10-16VDC

IGNITION PWR current: 5A max when using DBC module also

IGNITION PWR input protection: Over voltage up to 60V and reverse voltage up to 16V

BRAKE SW+ input voltage: 10-16VDC

BRAKE SW+ input protection: Over voltage up to 60V and reverse voltage up to 16V

BRAKE SW input activation voltage: 10-16VDC

BRAKE SW input protection: Over voltage up to 60V and reverse voltage up to 16V

CLUTCH+ input activation voltage: 10-16VDC

CLUTCH+ input protection: Over voltage up to 60V and reverse voltage up to 16V

CLUTCH- input activation voltage: 0-3 VDC

CLUTCH- input protection: Over voltage up to 60V and reverse voltage up to 16V

SET/COAST, RES/ACCEL and ON/OFF activation voltage: 10-16VDC

SET/COAST, RES/ACCEL and ON/OFF input protection: Over voltage up to 60V and reverse voltage up to 16V

RESISTIVE input voltage: 0-16VDC

RESISTIVE resistance range: Tested from 120 ohm to 22K ohm

SW +12V output current: 0.25A max

Speed Input PPM range: Autocal: 1,500-128,500PPM Preset 2,000, 4,000, 8,000, 16,000, 128,000PPM

Speed Input Minimum signal level: 1.5VPP / 0.35 Volts AC with volt meter.

Tach Input pulses per revolution range: 4 to 12 cylinders (2 to 6 PPR)

Tach signal level: Low voltage 5VPP, High voltage 12VPP or signal from – side of the coil

Wireless interface: BLE (Bluetooth Low Energy)

OBDII requests per second: 8

Supported EFI systems: Holley, AEM, MegaSquirt, Haltech, FiTech and Aces

SAFETY PROCEDURES

This unit is a microprocessor-based Cruise Control. It is designed for ease of installation. Carefully follow the installation procedures in this manual for best results.

DO NOT INSTALL THIS SYSTEM ON A DIESEL-POWERED VEHICLE WHICH HAS A MANUAL TRANSMISSION WITHOUT A DISENGAGEMENT SWITCH ON THE CLUTCH PEDAL ASSEMBLY.

WARNING

Failure to follow the instruction manual could not only cause the system to work improperly, but could cause the vehicle to go into 'limp-mode', possibly causing damage to your vehicle and injury and/or death to you and your passengers.

Only install on approved applications. The product described in this manual was developed, manufactured and tested in line with recognized technical standards and is in compliance with the fundamental safety requirements. Nevertheless, there are residual risks! It is therefore important to read this manual before installing and connecting the product. Keep the manual in a place that is readily accessible at all times.

Modifications to the product

The cruise control is designed, manufactured and tested with due regard to safety and reliability. Modifying or tampering with the product can affect its safety. This can lead to death, serious or slight injury to the driver or third parties, or damage to property or the environment. For this reason, the product must not be modified or tampered with!



WARNING: DO NOT USE HAND-HELD 2-WAY TRANSCEIVERS INSIDE YOUR VEHICLE WHILE DRIVING.

WHEN TRANSMITTING FROM INSIDE THE CAR, 2-WAY RADIOS THAT OPERATE IN THE 25MHz-700MHz FREQUENCY RANGE WITH MORE THAN 2.0 WATTS OF POWER CAN PRODUCE ELECTROMAGNETIC INTERFERENCE THAT COULD INTERFERE WITH THE OPERATION OF CRUISE AND THROTTLE CONTROLS RESULTING IN VEHICLE "LIMP MODE".

USE OF CELLULAR PHONES WILL NOT INTERFERE WITH THESE CONTROLS.



DUE TO SENSITIVE NATURE OF SIGNALS USED FOR THIS PRODUCT, ALL NON-PLUG AND PLAY CONNECTIONS MUST BE SOLDERED. FAILURE TO COMPLY WITH THIS REQUIREMENT WILL VOID WARRANTY.

⚠ WARNING: This product can expose you to chemicals including lead, which is known to the State of California to cause cancer and birth defects or other reproductive harm. For more information go to www.P65Warnings.ca.gov

Notes:

SERVICE AND REPAIR

DAKOTA DIGITAL offers complete service and repair of its product line. In addition, technical support is available to help you work through any questions or problems you may be having installing one of our products. Please read through the Troubleshooting Guide. There, you will find the solution to most problems.

For additional support, please visit www.dakotadigital.com. A “**Product Support**” link will be found at the bottom of the home page.

Should you ever need to send the unit back for repairs, please call our technical support line, (605) 332-6513, to request a Return Merchandise Authorization number.

- Package the product in a good quality box along with plenty of packing material.
- Ship the product by a common carrier with tracking abilities.
- Be sure to include the RMA number on the package.
- Include a complete description of the problem, with RMA number, your full name and address (street address preferred), and a telephone number where you can be reached during the day.
- Any returns for warranty work must include a copy of the dated sales receipt from your place of purchase.
- Send no money. We will contact you for payment.

Dakota Digital 60 Month Warranty

DAKOTA DIGITAL warrants to the ORIGINAL PURCHASER of this product that should it, under normal use and condition, be proven defective in material or workmanship for 60 MONTHS FROM THE DATE OF PURCHASE, such defect(s) will be repaired or replaced at Dakota Digital’s option.

This warranty does not cover nor extend to damage to the vehicle’s systems, and does not cover diagnosis, removal or reinstallation of the product.

This Warranty does not apply to any product or part thereof which in the opinion of the Company has been damaged through alteration, improper installation, mishandling, misuse, neglect, or accident.

Dakota Digital assumes no responsibility for loss of time, vehicle use, owner inconvenience nor related expenses.

Dakota Digital will cover the return standard freight once the product has been evaluated for warranty consideration, however the incoming transportation is to be covered by the owner.

This Warranty is in lieu of all other expressed warranties or liabilities. Any implied warranties, including any implied warranty of merchantability, shall be limited to the duration of this written warranty. No person or representative is authorized to assume, for Dakota Digital, any liability other than expressed herein in connection with the sale of this product.



4510 W. 61st St. North
Sioux Falls, SD 57107
www.dakotadigital.com
dakotasupport@dakotadigital.com

Phone (605) 332-6513
Fax (605) 339-4106

© Copyright 2025 - Dakota Digital