

# ***Dakota Digital***

## REMOTE UP/DOWN WINDOW CONTROL Or LOCK/UNLOCK CONTROL CMD-1000

Thank you for purchasing the Remote Window Control from Dakota Digital. These units have been designed to universally interface to virtually any power window regulator or door lock system on the market. This system will raise and lower one power window or lock and unlock the doors. A third channel can also be used for a trunk latch release or other 12 volt accessory.

### **Mounting:**

The receiver module should be mounted up under the dash on either the drivers side or the passenger side of the vehicle. Plug in the 10 pin harness to the mating connector on the control module. Route the antenna lead as high as possible behind the dash and as far across as possible. Do not coil it or wrap it around an existing wiring harness. The receiver module is not sealed and should not be mounted where it can be exposed to water.

### **Wiring:**

Connect the RED power wire to constant-on +12 volts and the BLACK wire to chassis ground. Connect the remaining wires to relays according to the wiring diagram specific to your type of application. There are two types of power window switches commonly used. One type switches the power to the window regulator directly. When the switch is at rest, it keeps both of the window regulator wires grounded. The other type switches 12 volts only to a relay pack and the relay provides the power to the window regulator. Your remote window control system wires differently depending on the type of the switch that is being used.

### **Window Control Operation:**

To operate the window, press button #1. As long as the button is held, the window will continue to move. To stop the window at any point of its travel, simply release the button. The window direction can then be reversed by pressing button #2. Button #3 can activate a relay for a trunk latch release or other 12 volt accessory. **Channel 3 has a three-second delay before it turns on.**

### **Lock/Unlock Control Operation:**

To unlock the door, press button #1. As long as the button is held, the door motor will be powered. The button should only be held a few seconds to prevent damaging the door motor. To lock the door, press button #2. Button #3 can activate a relay for a trunk latch release or other 12 volt accessory. **Channel 3 has a three-second delay before it turns on.**

The electrical operation of the system is as follows:

Button pressed

None	WHITE, GREEN, and ORANGE wires are open (floating).
#1	GREEN wire is grounded to activate a relay.
#2	ORANGE wire is grounded to activate a relay.
#3	WHITE wire is grounded to activate a relay.

Connection to Ball's, GM, Specialty,  
Dakota Digital, Springfield Street Rod,  
and similar power window systems.

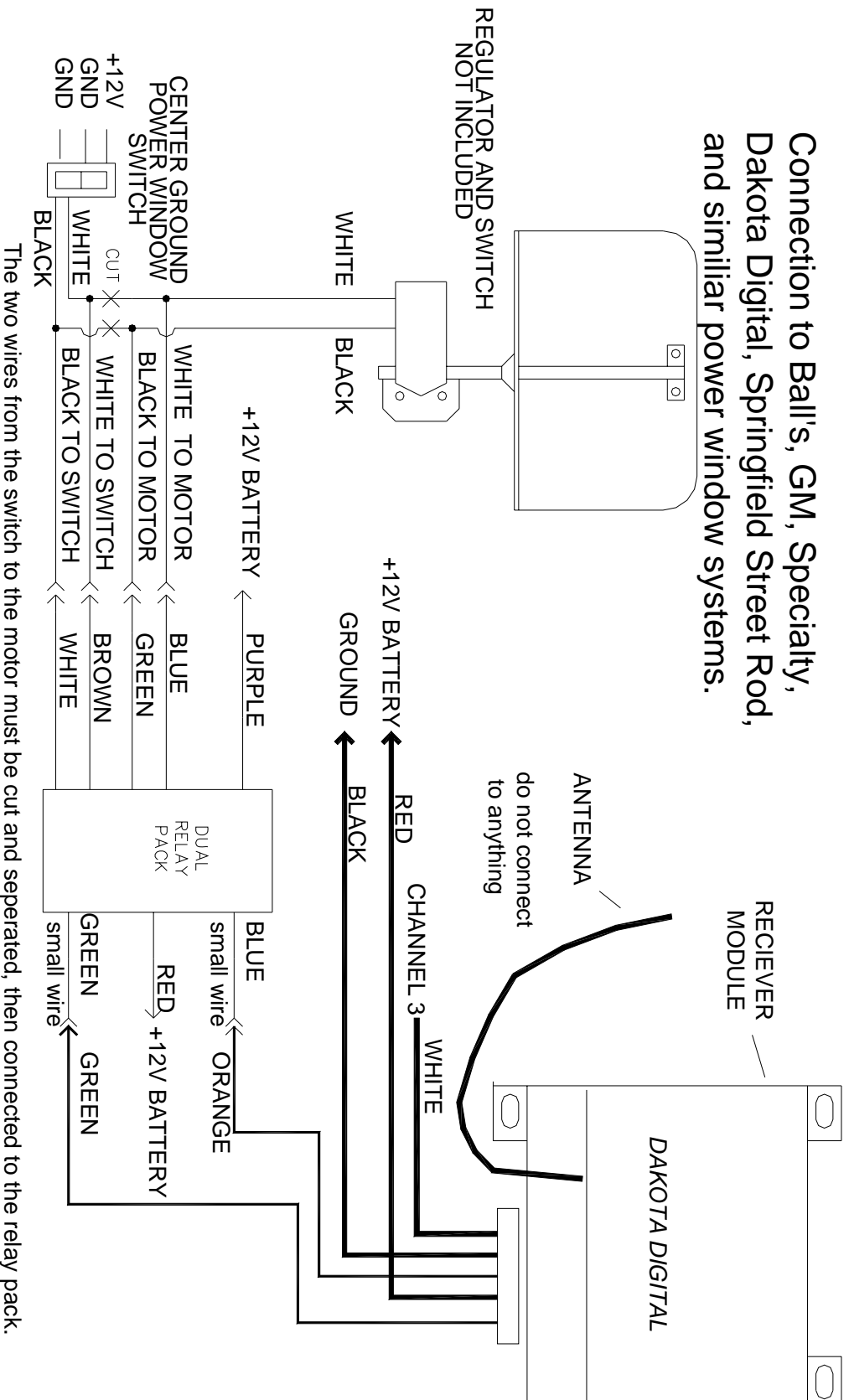

## Connection to 4-wire, center open power window switches.

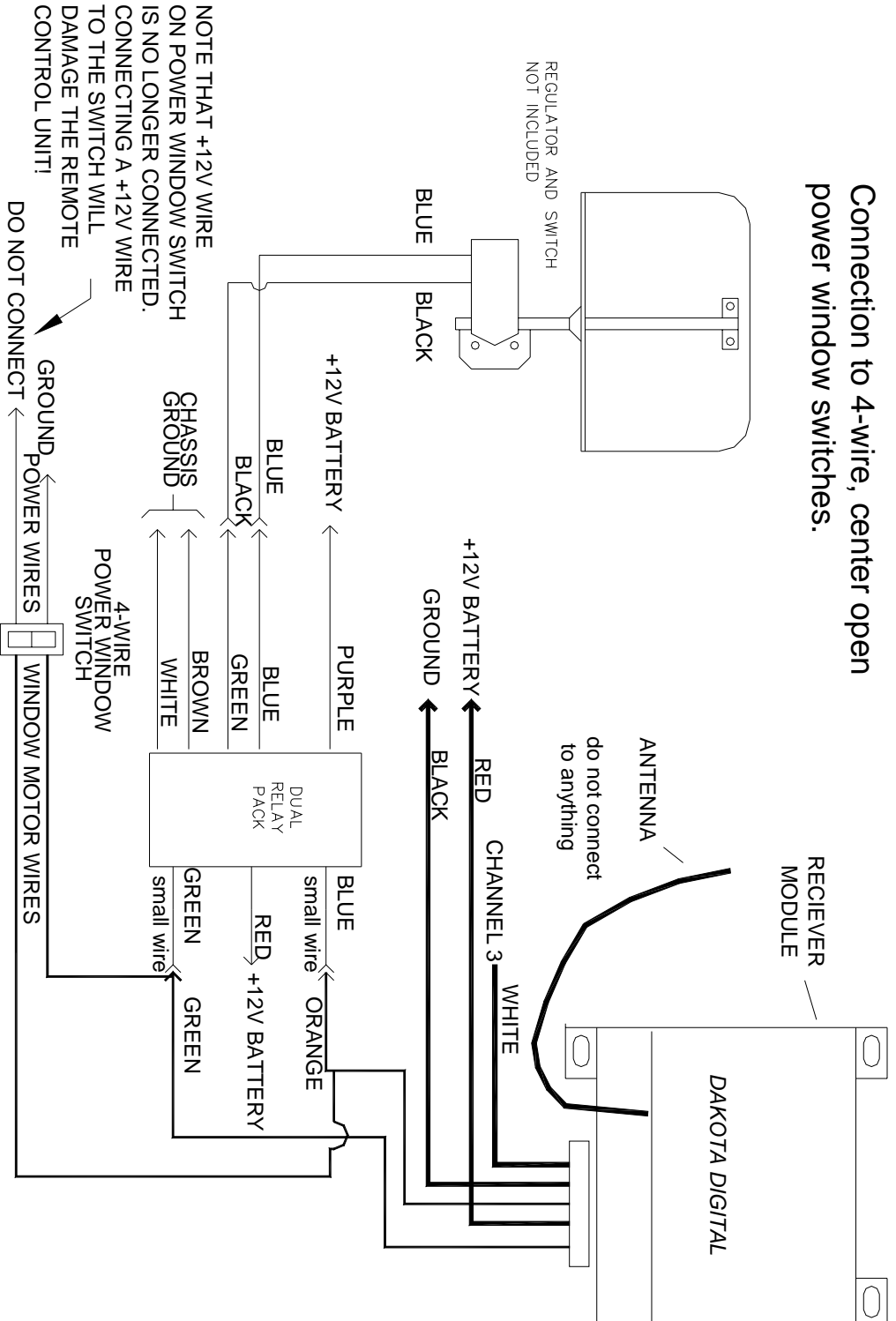

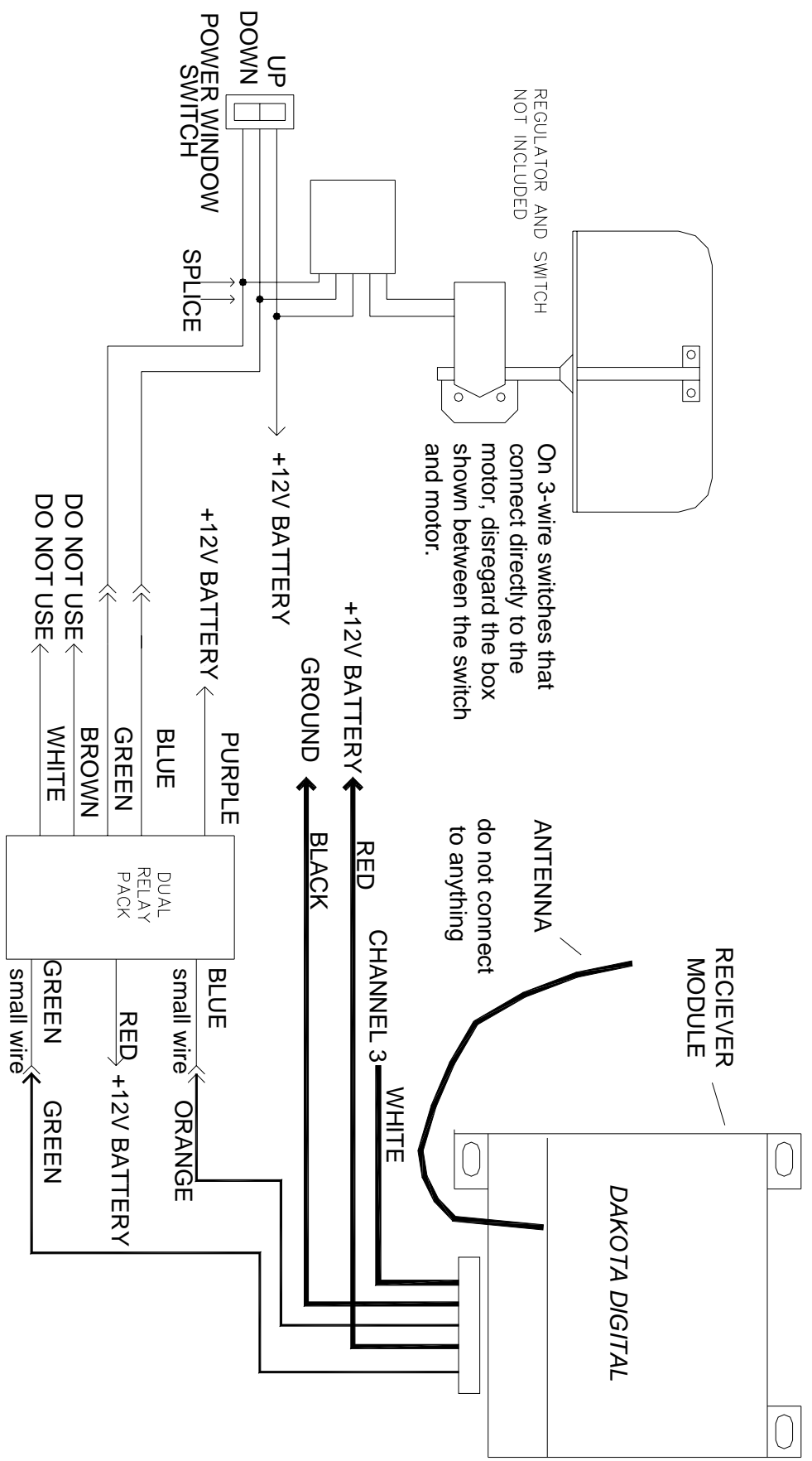

Connection to door lock motors directly without a switch.

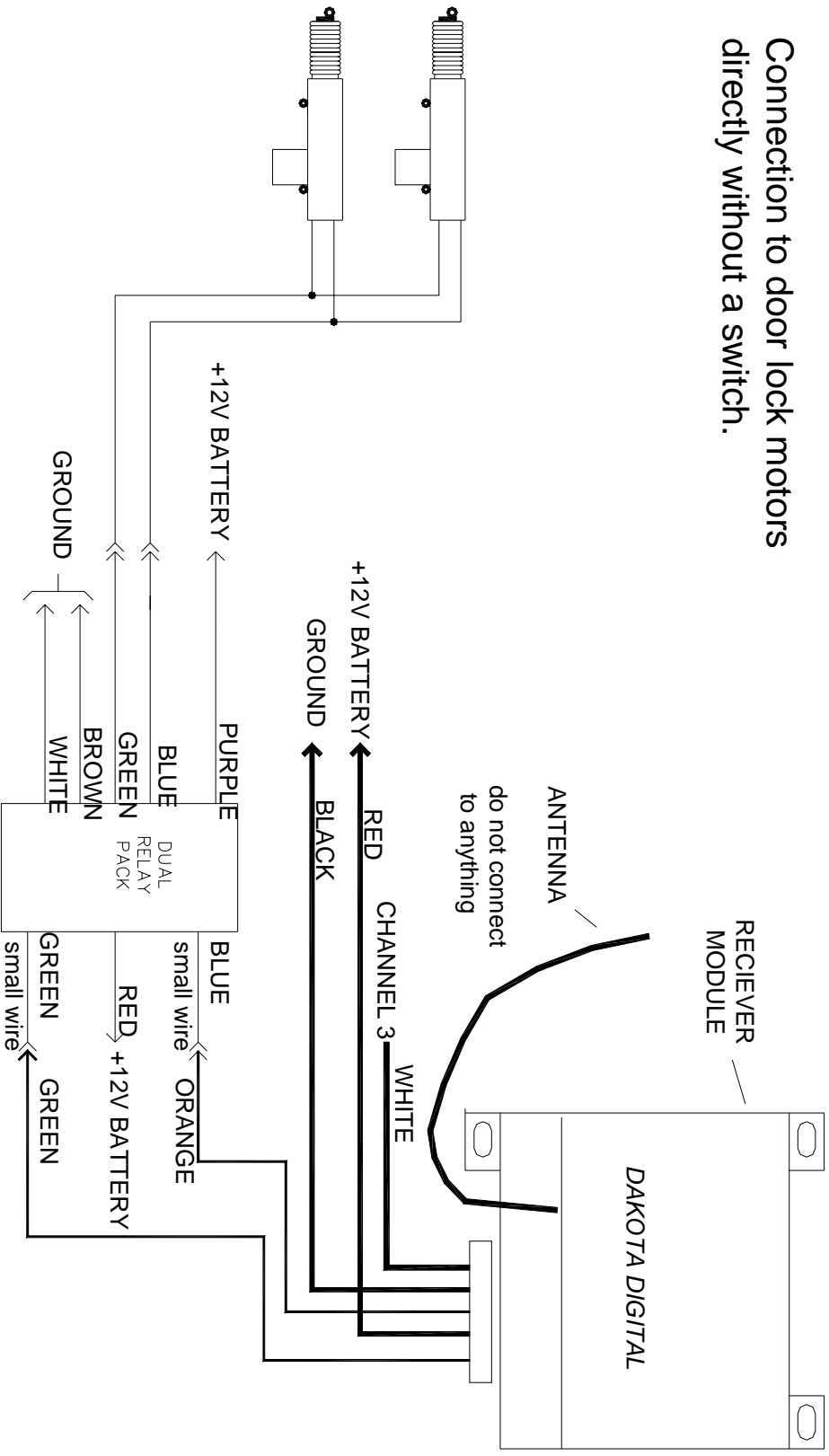

# Connection to door lock motors with a 5-wire switch.

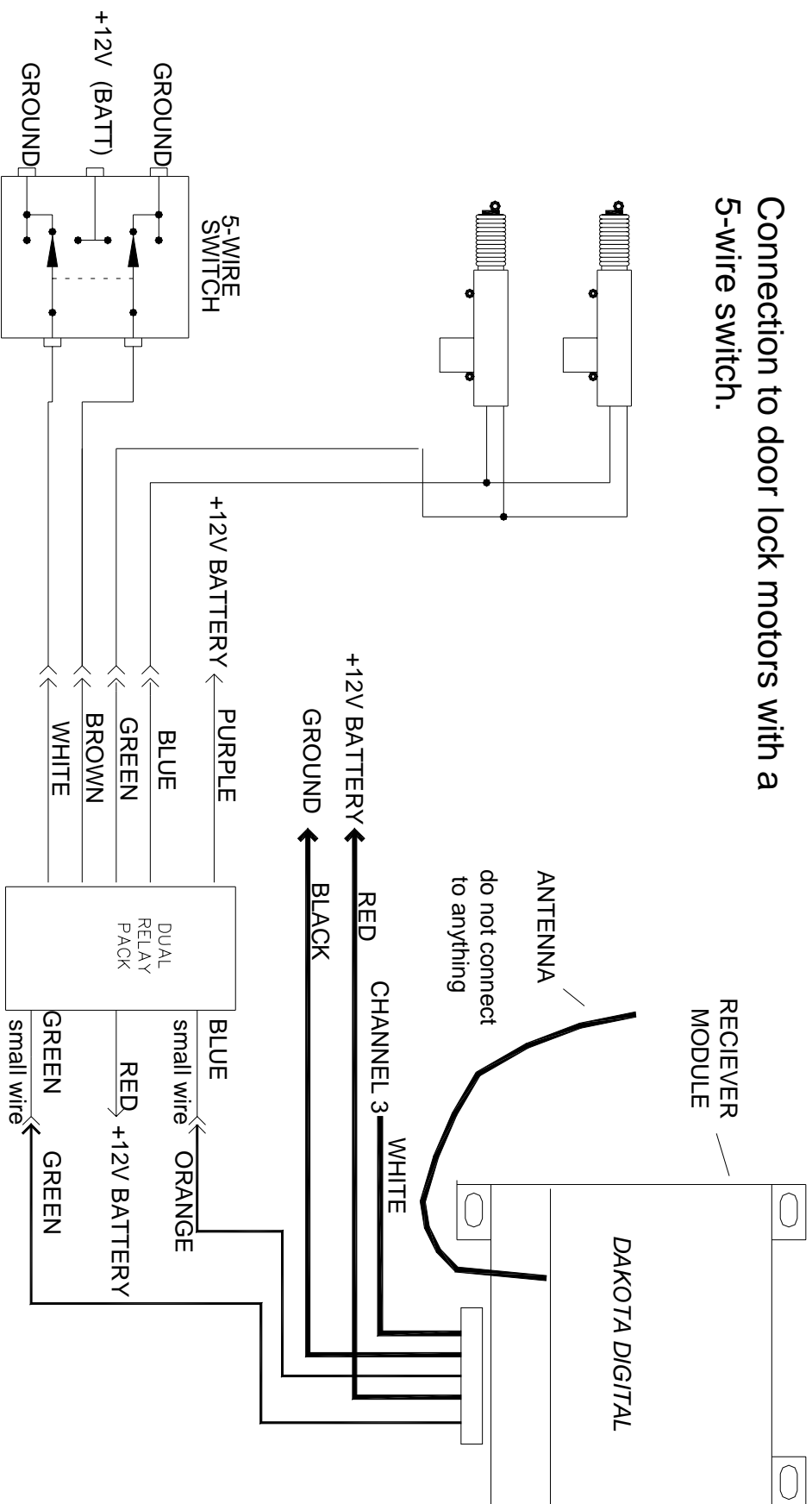

### Connection to factory door lock motors with a 3-wire switch.

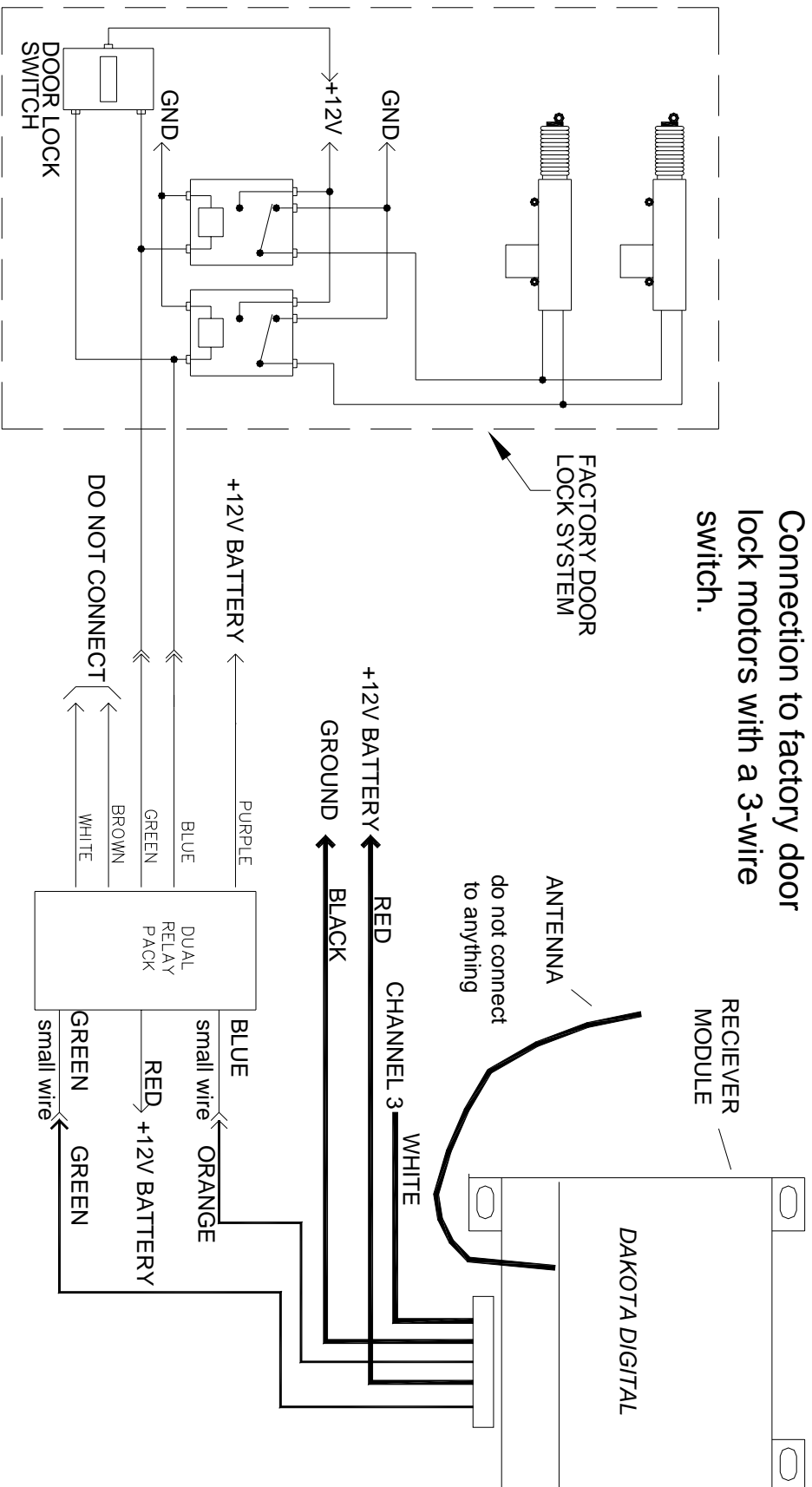

Using Channel 3  
for a trunk latch  
release or other  
12 volt  
accessory.

\* wire colors listed in  
( ) are for alternate  
relay sockets found  
in some units.

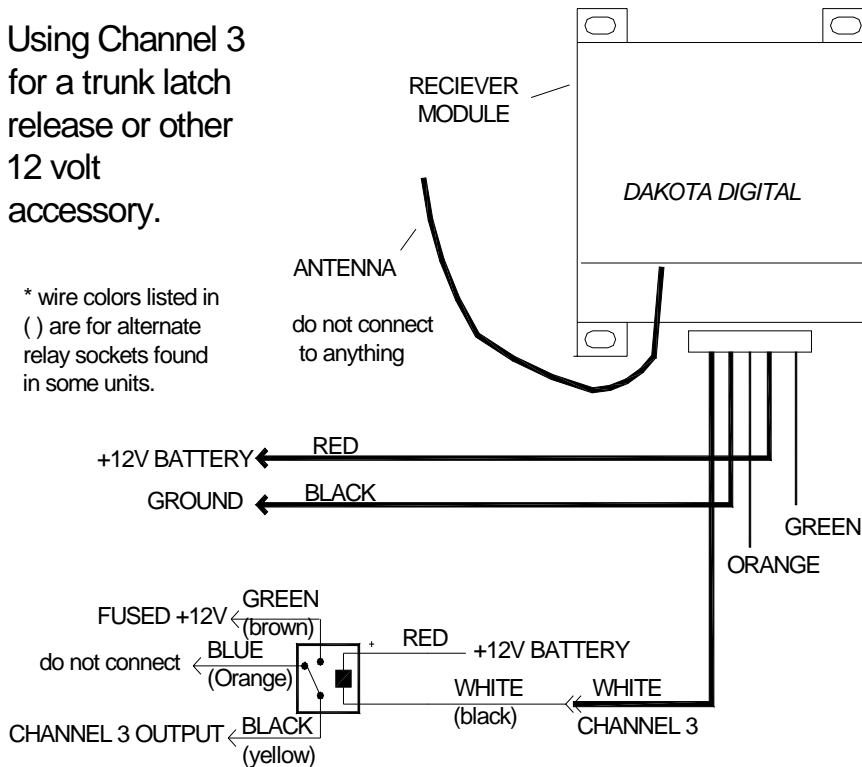

#### BATTERY REPLACEMENT

Should the transmitter function become weak or erratic, the battery in the keychain transmitter may be weak. An indication of a weak battery is that the red indicator may have a dim glow to it when either button is pressed. If this occurs, first check the system by using the second transmitter provided. If the second transmitter function properly, replace the battery in the defective transmitter by the following method:

- Remove the small screw on the back of the transmitter case.
- Carefully separate the two case halves.
- Remove the battery noting the (+) and (-) position.
- Replace the battery with a new 12 volt type GP23A battery which is available at most electronic stores (Radio Shack, etc.).
- Carefully replace the top cover and refasten the screw.
- Check transmitter function. Should the transmitter still fail to function, contact Dakota Digital, Inc..

## CMD-1000 REMOTE UP/DOWN WINDOW CONTROL LIMITED LIFETIME WARRANTY

**DAKOTA DIGITAL, Inc.** (the Company) warrants to the ORIGINAL PURCHASER of this remote control product that should any included control relay(s), electronic module, or transmitters under normal use and condition, be proven defective in material or workmanship DURING THE LIFETIME OF THE CAR IN WHICH IT WAS ORIGINALLY INSTALLED, such defect(s) will be repaired or replaced (at the Company's option) without charge for parts or labor directly related to repairs of the defect(s).

To obtain repair or replacement within the terms of this Warranty, the product is to be delivered with proof of warranty coverage (e.g. dated bill of sale), specification of defect(s), transportation prepaid, to the factory. This Warranty is valid for the original purchaser only and may not be transferred.

This Warranty does not cover batteries, nor extend to damage to vehicle electrical system. This Warranty does not apply to any product or part thereof which in the opinion of the Company has been damaged through alteration, improper installation, mishandling, misuse, neglect, or accident.

This Warranty is in lieu of all other express warranties or liabilities. ANY IMPLIED WARRANTIES, INCLUDING ANY IMPLIED WARRANTY OF MERCHANTABILITY, SHALL BE LIMITED TO THE DURATION OF THIS WRITTEN WARRANTY. ANY ACTION FOR BREACH OF ANY WARRANTY HEREUNDER INCLUDING ANY IMPLIED WARRANTY OF MERCHANTABILITY MUST BE BROUGHT WITHIN A PERIOD OF 30 MONTHS FROM DATE OF ORIGINAL PURCHASE. IN NO CASE SHALL THE COMPANY BE LIABLE FOR ANY CONSEQUENTIAL OR INCIDENTAL DAMAGES FOR BREACH OF THIS OR ANY OTHER WARRANTY, EXPRESSED OR IMPLIED, WHATSOEVER. No person or representative is authorized to assume for the Company any liability other than expressed herein in connection with the sale of this product.

The Company does not warrant that this product cannot be compromised or circumvented. THE EXTENT OF THE COMPANY'S LIABILITY UNDER THIS WARRANTY IS LIMITED TO THE REPAIR OR REPLACEMENT PROVIDED ABOVE AND, IN NO EVENT, SHALL THE COMPANY'S LIABILITY EXCEED THE PURCHASE PRICE PAID BY THE PURCHASER FOR THE PRODUCT.

Some states do not allow limitations on how long an implied warranty lasts or the exclusion or limitation if incidental or consequential damage so the above limitations or exclusion may not apply to you. This Warranty gives you specific legal rights and you may also have other rights which vary from state to state.

# **Dakota Digital**

4510 W. 61ST St. N., Sioux Falls, SD 57107  
Phone: (605) 332-6513 FAX: (605) 339-4106

[www.dakotadigital.com](http://www.dakotadigital.com)  
[dakotasupport@dakotadigital.com](mailto:dakotasupport@dakotadigital.com)

©Copyright 2004 Dakota Digital Inc.