

Odyssey

Manufactured by **Dakota Digital**

ODY-19-6

DUAL, TRIPLE, or QUAD AIR PRESSURE GAUGE

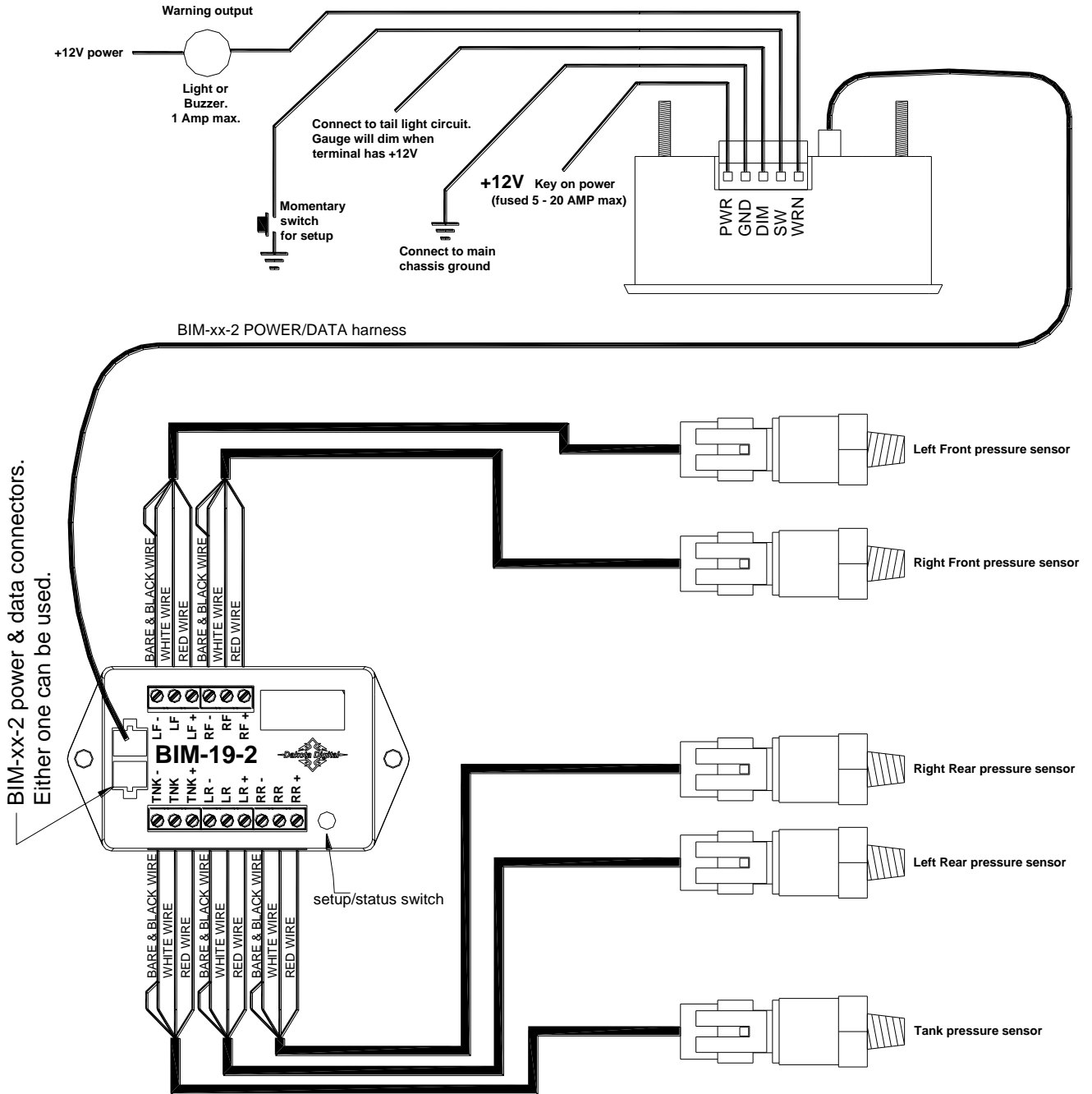

Operation:

The gauge needs only the PWR and GND terminals connected to light up. When the DIM terminal has 12 volts, it will dim the display for night viewing. The BIM-19-2 provides all of the sensor connections and attaches to the gauge with the supplied BIM power/data cable.

The senders must be Dakota Digital part SEN-03-9. Sending units from other manufacturers will cause incorrect readings. SEN-03-9 has 1/8" NPT threads. If other thread sizes are needed, an adapter fitting should be used to change the thread size. If a sender is giving an incorrect reading, the display will show "EE". If the sender is shorted to ground, the display will show "--".

The display will flash and the warning output will be set whenever one of the displayed pressures is out of the warning set limits.

The default setup for the BIM-19-2 will work correctly with the ODY-19-6 kit. Additional specifics about the BIM-19-2 can be found in its separate manual.

Air Ride setup options:

	4 bag	3 bag	Front/Rear	Left/Right
LR -	LEFT REAR	REAR	REAR	LEFT
RR -	RIGHT REAR	not connected	not connected	RIGHT
LF -	LEFT FRONT	LEFT FRONT	FRONT	not connected
RF -	RIGHT FRONT	RIGHT FRONT	not connected	not connected
TNK -	TANK (optional for all bag setups)			

Specs for each input are:

Part #	Range	resolution	low warning	high warning
SEN-03-9	0 - 300psi	1	0 – 252	48 – 300

Using external warning indicators:

The WRN terminal provides a ground trigger whenever any of the senders are outside the set limits. Low current indicators (less than 1 A) can be activated directly by connecting their power wire to 12 volts and connecting their ground wire to the WRN terminal.

For higher current buzzers or lights, a relay will need to be used to switch the indicator on. Dakota Digital's RLY-1 30A relay may be used for this. One of the coil wires should be connected to 12 volts and the other coil wire connected to the WRN terminal. When the gauge is outside its limits, the relay will turn on. The relay contact wires can be used to switch the higher current.

Setting the warning limit:

The low and high warning limits can be set to different values for each sensor. A push button switch connected to the SW terminal is used for setting the warning limit. The switch should provide a momentary ground to the SW terminal. The procedure for setting the warning limit is as follows:

1. Hold the switch while you turn the key on. The display should light up and show "WARNING" "SETUP".
2. Release the switch. The display should show "FOUND x SENDERS" with 'x' indicating the number of senders detected. This number should match the number of senders connected to the BIM-19. Only senders that are connected can have their warning points set. (if 0 is shown, check the BIM and sender connections and then momentarily press the switch)
3. The display will show the first sender label and its ID #.
4. Each time the switch is momentarily pressed it will go to the next sender.
5. When the desired sender is shown, press and hold the switch. When the lower section of the display blanks, release the switch.
6. The display will now show "Warning Lo" and the current low warning point (0 – 252).
7. Each time the switch is momentarily pressed the low warning point will increase.
8. When the desired low warning point is displayed, press and hold the switch. When the text blanks, release the switch.
9. The display will now show "Warning Hi" and the current high warning point (48 – 300).
10. Each time the switch is momentarily pressed the high warning point will increase.
11. When the desired high warning point is displayed, press and hold the switch. When the text blanks, release the switch.
12. The display will now go back to the sender selection screen in step 4. You can select another sender to set or turn the key off to exit setup.

Mounting:

The gauge requires a rectangular cut out that is about 3-3/8" x 1-11/16". It should be inserted into the opening from the front and the U-clamp will be installed from the back. Tighten the two nuts on the U-clamp so that the gauge is secure.

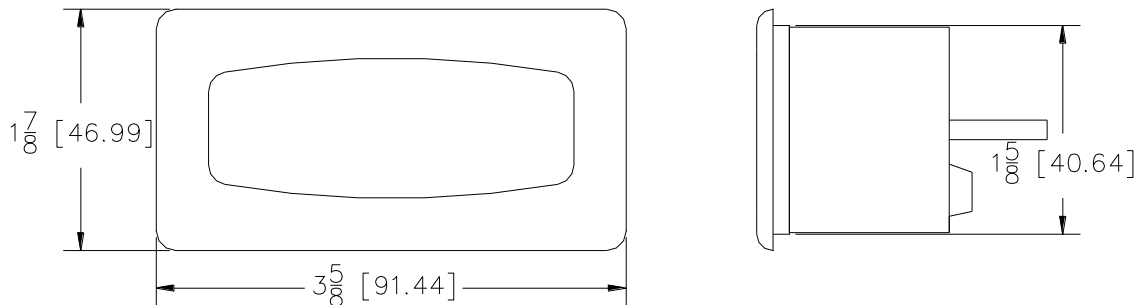
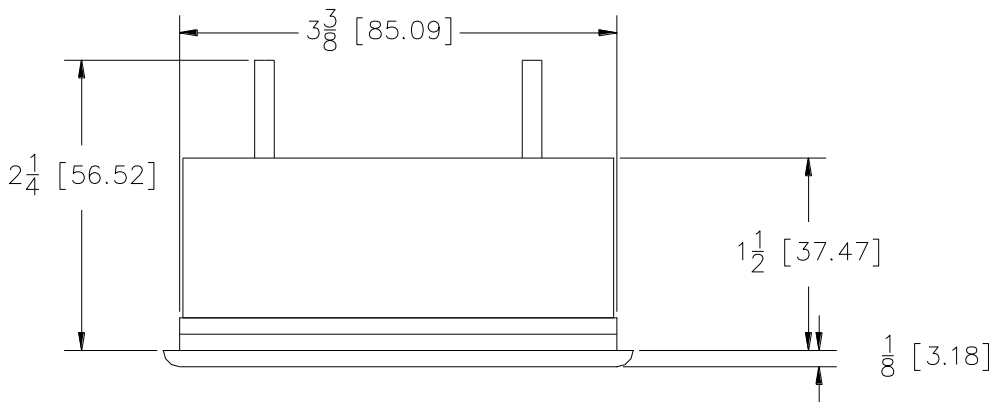
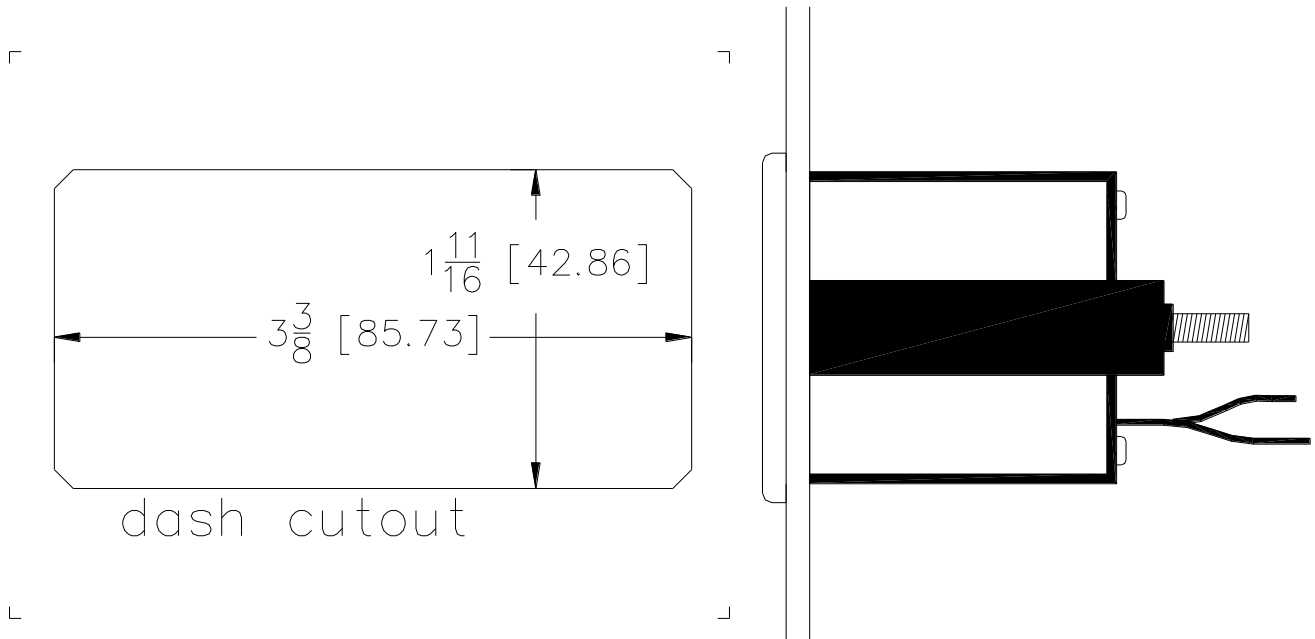

Troubleshooting guide.

Problem	Possible cause	Solution
Gauge will not light up	PWR terminal does not have power. GND terminal is not getting a good ground.	Connect to a location that has power. Connect ground to a different location.
Gauge lights up, but displays "No Senders Found"	Gauge is damaged. BIM-19 is not connected. BIM-19 is not powered. Check power connections on BIM-19. Data cable is not plugged in securely.	Return gauge for repair. (see instructions) Connect a BIM-19 using the power/data cable. Check both ends of the data cable.
Gauge lights up, but displays "BIM-19 SIGNAL ERROR"	BIM-19 is not connected. BIM-19 is not powered. Check power connections on BIM-19. Data cable is not plugged in securely.	Connect a BIM-19 using the power/data cable. Check both ends of the data cable.
Gauge lights up, but displays "EE".	Sender is not connected to BIM-19. Wires are crossed or shorted. Wire between BIM-19 and sender is broken. BIM-19 is damaged. Sender is damaged.	Connect wires from sender to BIM-19 terminals. Verify sender connection to BIM-19. Test and replace wire.
Gauge lights up, but displays "--".	Sender wire is shorted to ground. Wire between BIM-19 and sender is broken. BIM-19 is damaged. Sender is damaged.	Check wire for damaged insulation, replace if necessary. Test and replace wire.
Gauge lights up, but does not read correctly.	Loose connection on power wire. Poor sender ground. Poor ground connection. Incorrect sender type.	Reconnect wire going to PWR terminal. Make sure gauge and BIM are getting a solid ground. Move ground to different location Make sure sender has been replaced with the correct type (SEN-03-9). Reset warning limits.
Gauge flashes constantly.	Warning limits are not set properly. Vehicle has improper air pressure.	Reset warning limits. Check air level and air pump.
External warning indicator does not work.	Indicator not connected properly. Indicator does not work. Gauge output has been damaged.	Check indicator wiring connections. Repair or replace indicator. Return gauge for repair. (see instructions)
Gauge will not dim.	DIM terminal is not connected correctly.	Check wiring connections.
Gauge remains dim at all times.	Gauge is damaged. DIM terminal is getting power all of the time. Battery is very low. Gauge is damaged.	Return gauge for repair. (see instructions) Connect DIM terminal to location that only has power when the headlights are on. Recharge or replace vehicle battery. Return gauge for repair. (see instructions)

Technical specifications

Minimum operating voltage	-	7 volts
Maximum operating voltage	-	18 volts
(operating at or near maximum rating for an extended time can damage unit)		
Maximum pressure reading	-	300 psi
Gauge Resolution	-	1 psi
Typical current draw (@ 13.8V)	-	0.2 A

SERVICE AND REPAIR

DAKOTA DIGITAL offers complete service and repair of its product line. In addition, technical consultation is available to help you work through any questions or problems you may be having installing one of our products. Please read through the Troubleshooting Guide. There, you will find the solution to most problems.

Should you ever need to send the unit back for repairs, please call our technical support line, (605) 332-6513, to request a Return Merchandise Authorization number. Package the product in a good quality box along with plenty of packing material. Ship the product by UPS or insured Parcel Post. Be sure to include the RMA number on the package, and include a complete description of the problem with RMA number, your full name and address (street address preferred), and a telephone number where you can be reached during the day. Any returns for warranty work must include a copy of the dated sales receipt from your place of purchase. Send no money. We will bill you after repair.

Dakota Digital 24 Month Warranty

DAKOTA DIGITAL warrants to the ORIGINAL PURCHASER of this product that should it, under normal use and condition, be proven defective in material or workmanship within 24 MONTHS FROM THE DATE OF PURCHASE, such defect(s) will be repaired or replaced at Dakota Digital's option.

This warranty does not cover nor extend to damage to the vehicle's systems, and does not cover removal or reinstallation of the product. This Warranty does not apply to any product or part thereof which in the opinion of the Company has been damaged through alteration, improper installation, mishandling, misuse, neglect, or accident.

This Warranty is in lieu of all other expressed warranties or liabilities. Any implied warranties, including any implied warranty of merchantability, shall be limited to the duration of this written warranty. Any action for breach of any warranty hereunder, including any implied warranty of merchantability, must be brought within a period of 24 months from date of original purchase. No person or representative is authorized to assume, for Dakota Digital, any liability other than expressed herein in connection with the sale of this product.

⚠ WARNING: This product can expose you to chemicals including lead, which is known to the State of California to cause cancer and birth defects or other reproductive harm. For more information go to www.P65Warnings.ca.gov



4510 W. 61st St. North
Sioux Falls, SD 57107
www.dakotadigital.com

Phone (605) 332-6513
Fax (605) 339-4106

dakotasupport@dakotadigital.com Copyright 2011 - Dakota Digital, Inc.